

SP-EVCP-RC (60)

Single Phase Voltage Monitoring and protection device with built in current limiting

The **SP-EVCP-RC** from matt:e incorporates our unique monitoring device that disconnects all poles including CPC in the event of a broken Neutral fault in line with Regulation 722.411.4.1(iv) and has the additional functionality for load curtailment in line with Regulation 722.311.20, isolating the charge point from the supply once the house consumption rises above the pre-set limit of 60amps and automatically restores the power to the charge point when the load falls back within a satisfactory level.

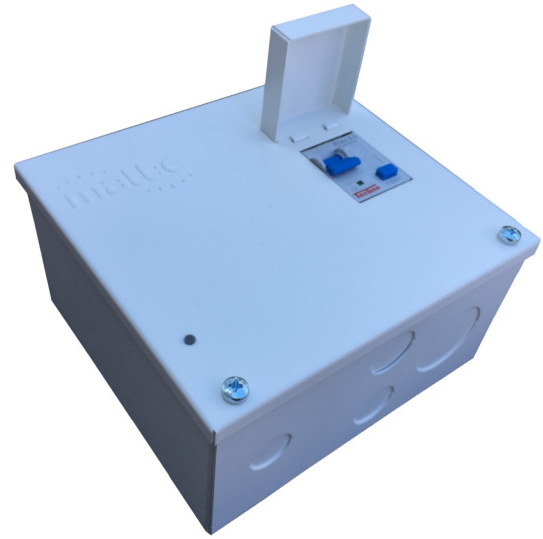

Creating a simple single connection centre that allows for compliant connection to the existing PME earthing facility without the use of Earth electrodes.

Product Features

- Built in matt:e technology
- BS:767118th Edition A1 compliant
- NO EARTH ELECTRODES REQUIRED
- Load management with hard wired CT factory set at 60A
- CT with simple plug and play connection
- Built in 32amp Double Pole Type A RCBO
- Standard 3 Year parts warranty
- Mild steel IPX enclosure
- Designed and Built in the UK

...Simplifying EV connection

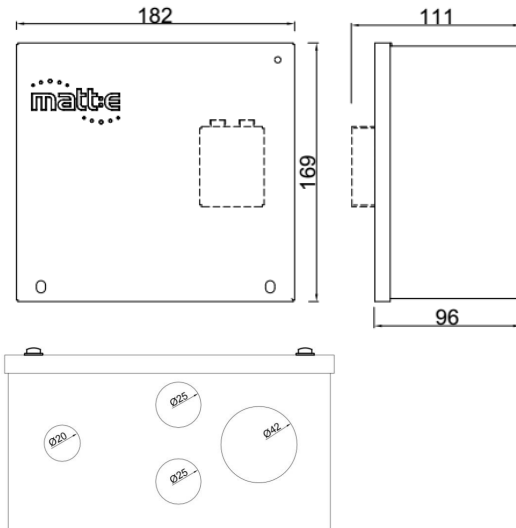
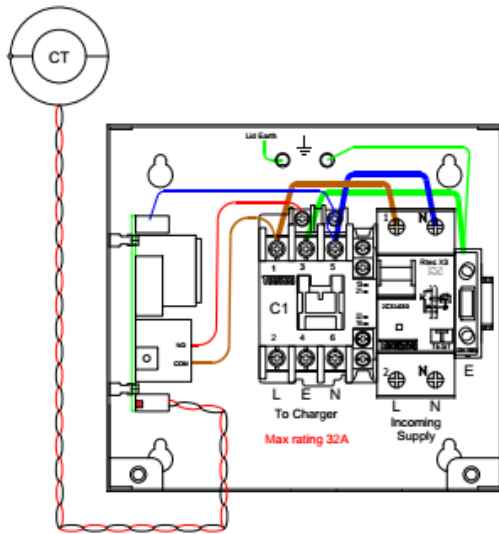

Description	Single Phase Voltage Monitoring and Protection Unit
Input Volts	Nominal input voltage Single Phase 230V 50Hz
Max Load	32 amps
Load Management	Pre set at 60A
CT Cable Length	1m
Cable Entry Facility	Bottom, 1 x 42mm 2 x 25mm 1 x 16mm
Terminal Capacity	10.0mm ²
Dimensions (H x W x D)	169mm x 182mm x 111mm
Weight	Approximately 3kG
Enclosure	Mild Steel Powder Coated
Ingress Protection	IP2X
Warranty	The matt:e SP-EVCP-RC is guaranteed for a period of 3 years from the date of purchase. This warranty is limited to the replacement of faulty components only.

...Simplifying EV connection