

---

# EMC Test Report

---

Report No.: AGC09609220501BE01

**PRODUCT DESIGNATION** : Battery

**BRAND NAME** : GivEnergy

**MODEL NAME** : Giv-Bat9.5

**APPLICANT** : Shenzhen GivEnergy Technology Co., Ltd

**DATE OF ISSUE** : May 10, 2022

**STANDARD(S)** : EN IEC 61000-6-3:2021  
EN IEC 61000-6-1:2019  
BS EN IEC 61000-6-3:2021  
BS EN IEC 61000-6-1:2019

**REPORT VERSION** : V1.0



Attestation of Global Compliance (Shenzhen) Co., Ltd



Any report having not been signed by authorized approver, or having been altered without authorization, or having not been stamped by the "Dedicated Testing/Inspection Stamp" is deemed to be invalid. Copying or excerpting portion of, or altering the content of the report is not permitted without the written authorization of AGC. The test results presented in the report apply only to the tested sample. Any objections to report issued by AGC should be submitted to AGC within 15days after the issuance of the test report. Further enquiry of validity or verification of the test report should be addressed to AGC by [agc01@agccert.com](mailto:agc01@agccert.com).

### REPORT REVISE RECORD

Report Version	Revise Time	Issued Date	Valid Version	Notes
V1.0	/	May 10, 2022	Valid	Initial release

**Note:**

This report is for approval of updating test specifications based on previous report AGC09609220501EE01.

Modification based on original report adding BS EN standard, no further testing is necessary.

Any report having not been signed by authorized approver, or having been altered without authorization, or having not been stamped by the "Dedicated Testing/Inspection Stamp" is deemed to be invalid. Copying or excerpting portion of, or altering the content of the report is not permitted without the written authorization of AGC. The test results presented in the report apply only to the tested sample. Any objections to report issued by AGC should be submitted to AGC within 15days after the issuance of the test report. Further enquiry of validity or verification of the test report should be addressed to AGC by [agc01@agccert.com](mailto:agc01@agccert.com).

## TABLE OF CONTENTS

<b>1 VERIFICATION OF CONFORMITY</b> .....	<b>4</b>
<b>2 SYSTEM DESCRIPTION</b> .....	<b>5</b>
<b>3 MEASUREMENT UNCERTAINTY</b> .....	<b>5</b>
<b>4 PRODUCT INFORMATION</b> .....	<b>6</b>
<b>5 SUPPORT EQUIPMENT</b> .....	<b>7</b>
<b>6 TEST FACILITY</b> .....	<b>8</b>
<b>7 TEST EQUIPMENT LIST</b> .....	<b>8</b>
<b>8 TEST SUMMARY LIST</b> .....	<b>9</b>
<b>9 EN IEC 61000-6-3 RADIATED EMISSION TEST</b> .....	<b>10</b>
9.1 LIMITS OF RADIATED DISTURBANCES.....	10
9.2 BLOCK DIAGRAM OF TEST SETUP.....	10
9.3 PROCEDURE OF RADIATED EMISSION TEST.....	11
9.4 TEST RESULT OF RADIATED EMISSION TEST.....	12
<b>10 EN 61000-4-2 ESD IMMUNITY TEST</b> .....	<b>14</b>
10.1 BLOCK DIAGRAM OF TEST SETUP.....	14
10.2 TEST PROCEDURE .....	15
10.3 PERFORMANCE & RESULT .....	16
<b>11 EN 61000-4-3 RS IMMUNITY TEST</b> .....	<b>17</b>
11.1 BLOCK DIAGRAM OF TEST SETUP.....	17
11.2 TEST PROCEDURE .....	18
11.3 PERFORMANCE & RESULT.....	19
<b>APPENDIX A: PHOTOGRAPHS OF TEST SETUP</b> .....	<b>20</b>
<b>APPENDIX B: PHOTOGRAPHS OF EUT</b> .....	<b>22</b>

Any report having not been signed by authorized approver, or having been altered without authorization, or having not been stamped by the “Dedicated Testing/Inspection Stamp” is deemed to be invalid. Copying or excerpting portion of, or altering the content of the report is not permitted without the written authorization of AGC. The test results presented in the report apply only to the tested sample. Any objections to report issued by AGC should be submitted to AGC within 15days after the issuance of the test report. Further enquiry of validity or verification of the test report should be addressed to AGC by [agc01@agccert.com](mailto:agc01@agccert.com).

### 1 VERIFICATION OF CONFORMITY

<b>Applicant</b>	Shenzhen GivEnergy Technology Co., Ltd
<b>Address</b>	Room 502, Building A, No.94, Guangtian Road, Yanchuan Community, Yanluo Street, Baoan District, Shenzhen, Guangdong, China
<b>Manufacturer</b>	Shenzhen GivEnergy Technology Co., Ltd
<b>Address</b>	Room 502, Building A, No.94, Guangtian Road, Yanchuan Community, Yanluo Street, Baoan District, Shenzhen, Guangdong, China
<b>Factory</b>	Shenzhen GivEnergy Technology Co., Ltd
<b>Address</b>	Room 502, Building A, No.94, Guangtian Road, Yanchuan Community, Yanluo Street, Baoan District, Shenzhen, Guangdong, China
<b>Product Designation</b>	Battery
<b>Brand Name</b>	GivEnergy
<b>Test Model</b>	Giv-Bat9.5
<b>Date of test</b>	May 09, 2022 to May 10, 2022
<b>Deviation</b>	The sample has no any deviation to the method of standard mentioned on page 1
<b>Condition of Test Sample</b>	Normal
<b>Test Result</b>	Pass

The above equipment was tested by Attestation of Global Compliance (Shenzhen) Co., Ltd. for compliance with the requirements set forth in the Technical Standards mentioned above. This said equipment in the configuration described in this report shows the maximum emission levels emanating from equipment and the level of the immunity endurance of the equipment are within the compliance requirements.

The test results of this report relate only to the tested sample identified in this report.

Prepared By   
 \_\_\_\_\_  
 Jack Gui  
 (Project Engineer) May 10, 2022

Reviewed By   
 \_\_\_\_\_  
 Calvin Liu  
 (Reviewer) May 10, 2022

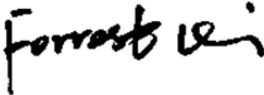
Approved By   
 \_\_\_\_\_  
 Forrest Lei  
 (Authorized Officer) May 10, 2022

Any report having not been signed by authorized approver, or having been altered without authorization, or having not been stamped by the "Dedicated Testing/Inspection Stamp" is deemed to be invalid. Copying or excerpting portion of, or altering the content of the report is not permitted without the written authorization of AGC. The test results presented in the report apply only to the tested sample. Any objections to report issued by AGC should be submitted to AGC within 15days after the issuance of the test report. Further enquiry of validity or verification of the test report should be addressed to AGC by agc01@agccert.com.

## 2 SYSTEM DESCRIPTION

TEST MODE DESCRIPTION		
NO.	TEST MODE DESCRIPTION	WORST
1	Discharging	V
2	Charging	--

Note:

1. V means EMI worst mode.
2. Only worst mode data recorded in the test report.

## 3 MEASUREMENT UNCERTAINTY

The uncertainty is calculated using the methods suggested in the “Guide to the Expression of Uncertainty in measurement” (GUM) published by ISO.

- Uncertainty of Radiated Emission Below 1GHz,  $U_c = \pm 3.8\text{dB}$

#### 4 PRODUCT INFORMATION

<b>Housing Type</b>	Plastic and metal
<b>EUT Input Rating</b>	DC 51.2V 186Ah
<b>EUT Output Rating</b>	DC 51.2V 186Ah
<b>Hardware Version</b>	N/A
<b>Software Version</b>	N/A

I/O Port Information (Applicable Not Applicable)

I/O Port of EUT			
I/O Port Type	Number	Cable Description	Tested With
DC IN/ DC OUT	2	--	2

Any report having not been signed by authorized approver, or having been altered without authorization, or having not been stamped by the "Dedicated Testing/Inspection Stamp" is deemed to be invalid. Copying or excerpting portion of, or altering the content of the report is not permitted without the written authorization of AGC. The test results presented in the report apply only to the tested sample. Any objections to report issued by AGC should be submitted to AGC within 15days after the issuance of the test report. Further enquiry of validity or verification of the test report should be addressed to AGC by agc01@agccert.com.

### 5 SUPPORT EQUIPMENT

Device Type	Manufacturer	Model Name	Serial No.	Data Cable	Power Cable
Resistance box	--	--	--	--	--

Note: All the above equipment/cables were placed in worse case positions to maximize emission signals during emission test.

Any report having not been signed by authorized approver, or having been altered without authorization, or having not been stamped by the "Dedicated Testing/Inspection Stamp" is deemed to be invalid. Copying or excerpting portion of, or altering the content of the report is not permitted without the written authorization of AGC. The test results presented in the report apply only to the tested sample. Any objections to report issued by AGC should be submitted to AGC within 15days after the issuance of the test report. Further enquiry of validity or verification of the test report should be addressed to AGC by agc01@agccert.com.

## 6 TEST FACILITY

<b>Site</b>	Attestation of Global Compliance (Shenzhen) Co., Ltd
<b>Location</b>	1-2/F, Building 19, Junfeng Industrial Park, Chongqing Road, Heping Community, Fuhai Street, Bao 'an District, Shenzhen, Guangdong, China

## 7 TEST EQUIPMENT LIST

### TEST EQUIPMENT OF RADIATED EMISSION TEST

Equipment	Manufacturer	Model	S/N	Cal. Date	Cal. Due
Test Receiver	R&S	ESCI	10096	Mar. 28, 2022	Mar. 27, 2023
Antenna	SCHWARZBEC K	VULB9168	494	Jan. 08, 2021	Jan. 07, 2023
Test software	FARA	EZ_EM (Ver.RA-03A)	N/A	N/A	N/A

### TEST EQUIPMENT OF ESD TEST

Equipment	Manufacturer	Model	S/N	Cal. Date	Cal. Due
ESD Simulator	EM Test	ditto	P1527160053	Jan. 08, 2022	Jan. 07, 2023

### TEST EQUIPMENT OF RS IMMUNITY TEST

Description	Manufacturer	Model	S/N	Cal. Date	Cal. Due
Signal Generator	R&S	E4421B	MY43351603	Mar. 04, 2022	Mar. 03, 2023
Power Sensor	R&S	URV5-Z4	100124	Apr. 26, 2021	Apr. 25, 2023
Power Meter	R&S	NRVD	8323781027	Apr. 26, 2021	Apr. 25, 2023
Power Amplifier	KALMUS	7100LC	04-02/17-06-001	N/A	N/A
Power Amplifier	Milmega	AS0104-55_55	1004793	N/A	N/A
Double-Ridged Waveguide Horn	ETS LINDGREN	3117	00034609	Apr. 23, 2021	Apr. 22, 2023
Antenna	SCHWARZBEC K	VULB9168	D69250	Apr. 28, 2021	Apr. 27, 2023

Any report having not been signed by authorized approver, or having been altered without authorization, or having not been stamped by the "Dedicated Testing/Inspection Stamp" is deemed to be invalid. Copying or excerpting portion of, or altering the content of the report is not permitted without the written authorization of AGC. The test results presented in the report apply only to the tested sample. Any objections to report issued by AGC should be submitted to AGC within 15days after the issuance of the test report. Further enquiry of validity or verification of the test report should be addressed to AGC by agc01@agccert.com.



## 8 TEST SUMMARY LIST

Test item	Test Requirement	Test Method	Class/Severity	Result
CONDUCTED EMISSION	EN IEC 61000-6-3	EN IEC 61000-6-3	EN IEC 61000-6-3	N/A
RADIATED EMISSION	EN IEC 61000-6-3	EN IEC 61000-6-3	EN IEC 61000-6-3	Pass
Harmonic current emission	EN 61000-3-2	EN 61000-3-2	Class A	N/A
Voltage fluctuations & flicker	EN 61000-3-3	EN 61000-3-3	§5 of EN 61000-3-3	N/A
Electrostatic Discharge Immunity	EN IEC 61000-6-1	EN 61000-4-2	± 8.0 kV (Air Discharge) ± 4.0 kV (Contact Discharge) ± 4.0 kV (Indirect Discharge)	Pass
Radiated RF Electromagnetic	EN IEC 61000-6-1	EN 61000-4-3	3V/mwith80% AM. 1kHz Modulation at 80-1000MHz 3V/mwith80% AM. 1kHz Modulation at 1400-6000MHz	Pass
Electrical fast transient/burst Immunity	EN IEC 61000-6-1	EN 61000-4-4	+/- 1kV for Power Supply Lines	N/A
SURGE IMMUNITY	EN IEC 61000-6-1	EN 61000-4-5	+/- 1kV (Line to Line) +/- 2kV (Line to Ground)	N/A
Immunity to Conducted Disturbances Induced by RF fields	EN IEC 61000-6-1	EN 61000-4-6	3V with 80% AM. 1 kHz Modulation	N/A
Power frequency magnetic field	EN IEC 61000-6-1	EN 61000-4-8	50/60Hz 3A/m	N/A
Voltage dips and short interruptions immunity	EN IEC 61000-6-1	EN 61000-4-11	PHASE ANGLE 0 degrees	N/A

**Note :** N/A means not applicable.

Any report having not been signed by authorized approver, or having been altered without authorization, or having not been stamped by the "Dedicated Testing/Inspection Stamp" is deemed to be invalid. Copying or excerpting portion of, or altering the content of the report is not permitted without the written authorization of AGC. The test results presented in the report apply only to the tested sample. Any objections to report issued by AGC should be submitted to AGC within 15days after the issuance of the test report. Further enquiry of validity or verification of the test report should be addressed to AGC by [agc01@agccert.com](mailto:agc01@agccert.com).

## 9 EN IEC 61000-6-3 RADIATED EMISSION TEST

### 9.1 LIMITS OF RADIATED DISTURBANCES

#### AT 10M DISTANCES

Frequency (MHz)	Distance (m)	Maximum Field Strength Limit (dBuV/m Q.P.)
30-230	10	30.00
230-1000	10	37.00

#### AT 3M DISTANCES

Frequency (MHz)	Distance (m)	Maximum Field Strength Limit (dBuV/m Q.P.)
30-230	3	40.00
230-1000	3	47.00

Note: The lower limit shall apply at the transition frequency.

### 9.2 BLOCK DIAGRAM OF TEST SETUP

System Diagram of Connections between EUT and Simulators

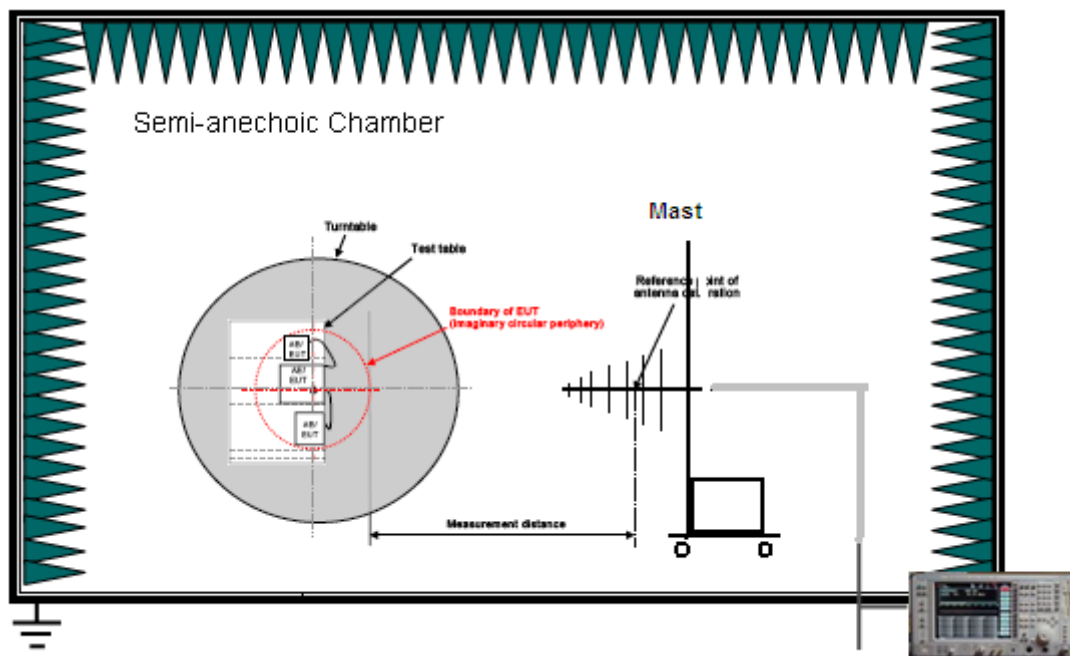

Any report having not been signed by authorized approver, or having been altered without authorization, or having not been stamped by the "Dedicated Testing/Inspection Stamp" is deemed to be invalid. Copying or excerpting portion of, or altering the content of the report is not permitted without the written authorization of AGC. The test results presented in the report apply only to the tested sample. Any objections to report issued by AGC should be submitted to AGC within 15days after the issuance of the test report. Further enquiry of validity or verification of the test report should be addressed to AGC by agc01@agccert.com.

### 9.3 PROCEDURE OF RADIATED EMISSION TEST

- (1) The equipment was set up as per the test configuration to simulate typical actual usage per the user's manual. When the EUT is a tabletop system, a wooden turntable with a height of 0.8 meters is used which is placed on the ground plane as per EN IEC 61000-6-3 (see Test Facility for the dimensions of the ground plane used). When the EUT is a floor-standing equipment, it is placed on the ground plane which has a 10cm non-conductive covering to insulate the EUT from the ground plane.
- (2) Support equipment, if needed, was placed as per EN IEC 61000-6-3.
- (3) All I/O cables were positioned to simulate typical actual usage as per EN IEC 61000-6-3.
- (4) The EUT connected to resistance box discharging.
- (5) The antenna was placed at 3 meter away from the EUT as stated in EN IEC 61000-6-3. The antenna connected to the Analyzer via a cable and at times a pre-amplifier would be used.
- (6) The Analyzer / Receiver quickly scanned from 30MHz to 1000MHz. The EUT test program was started. Emissions were scanned and measured rotating the EUT to 360 degrees and positioning the antenna 1 to 4 meters above the ground plane, in both the vertical and the horizontal polarization, to maximize the emission reading level.
- (7) The test mode(s) were scanned during the test.
- (8) Recorded at least the six highest emissions. Emission frequency, amplitude, antenna position, polarization and turntable position were recorded into a computer in which correction factors were used to calculate the emission level and compare reading to the applicable limit and Q.P./Peak reading is presented.

Any report having not been signed by authorized approver, or having been altered without authorization, or having not been stamped by the "Dedicated Testing/Inspection Stamp" is deemed to be invalid. Copying or excerpting portion of, or altering the content of the report is not permitted without the written authorization of AGC. The test results presented in the report apply only to the tested sample. Any objections to report issued by AGC should be submitted to AGC within 15days after the issuance of the test report. Further enquiry of validity or verification of the test report should be addressed to AGC by [agc01@agccert.com](mailto:agc01@agccert.com).

### 9.4 TEST RESULT OF RADIATED EMISSION TEST

#### Radiated Emission Test at 3m Distance-Horizontal

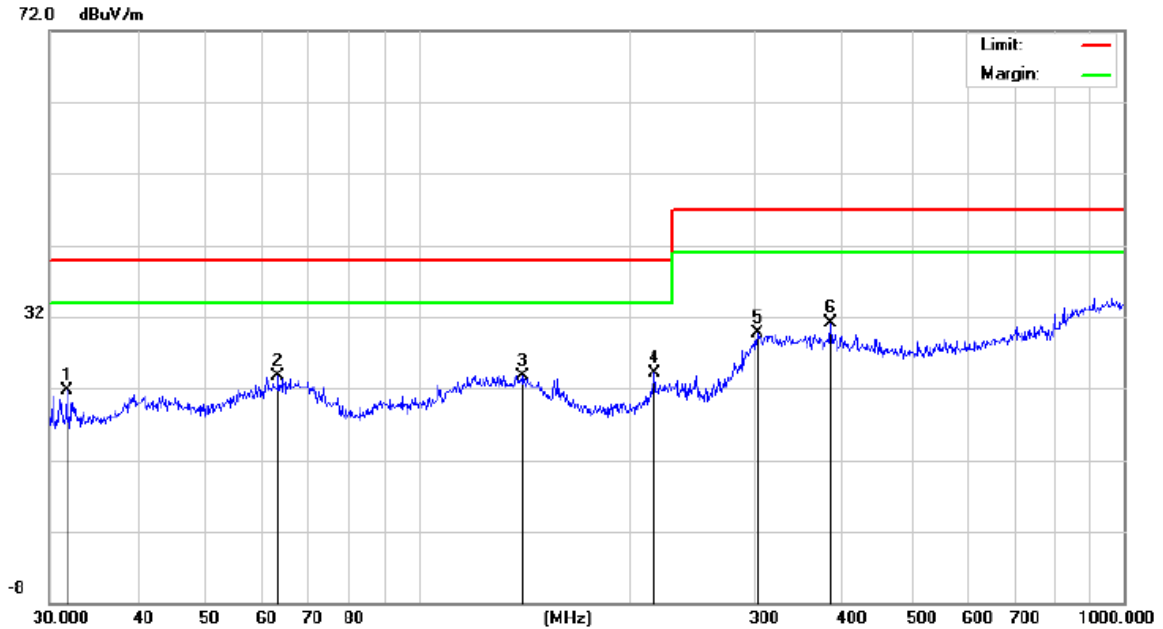

No.	Mk.	Freq. MHz	Reading Level dBuV	Correct Factor dB	Measure- ment dBuV/m	Limit dBuV/m	Over dB	Detector
1		31.7313	8.46	13.22	21.68	40.00	-18.32	peak
2		63.3132	5.94	17.69	23.63	40.00	-16.37	peak
3		140.8351	5.18	18.58	23.76	40.00	-16.24	peak
4		216.0240	6.48	17.61	24.09	40.00	-15.91	peak
5		302.4812	5.21	24.42	29.63	47.00	-17.37	peak
6	*	383.9318	7.33	23.80	31.13	47.00	-15.87	peak

**RESULT: PASS**

Any report having not been signed by authorized approver, or having been altered without authorization, or having not been stamped by the "Dedicated Testing/Inspection Stamp" is deemed to be invalid. Copying or excerpting portion of, or altering the content of the report is not permitted without the written authorization of AGC. The test results presented in the report apply only to the tested sample. Any objections to report issued by AGC should be submitted to AGC within 15days after the issuance of the test report. Further enquiry of validity or verification of the test report should be addressed to AGC by agc01@agccert.com.

Radiated Emission Test at 3m Distance-Vertical

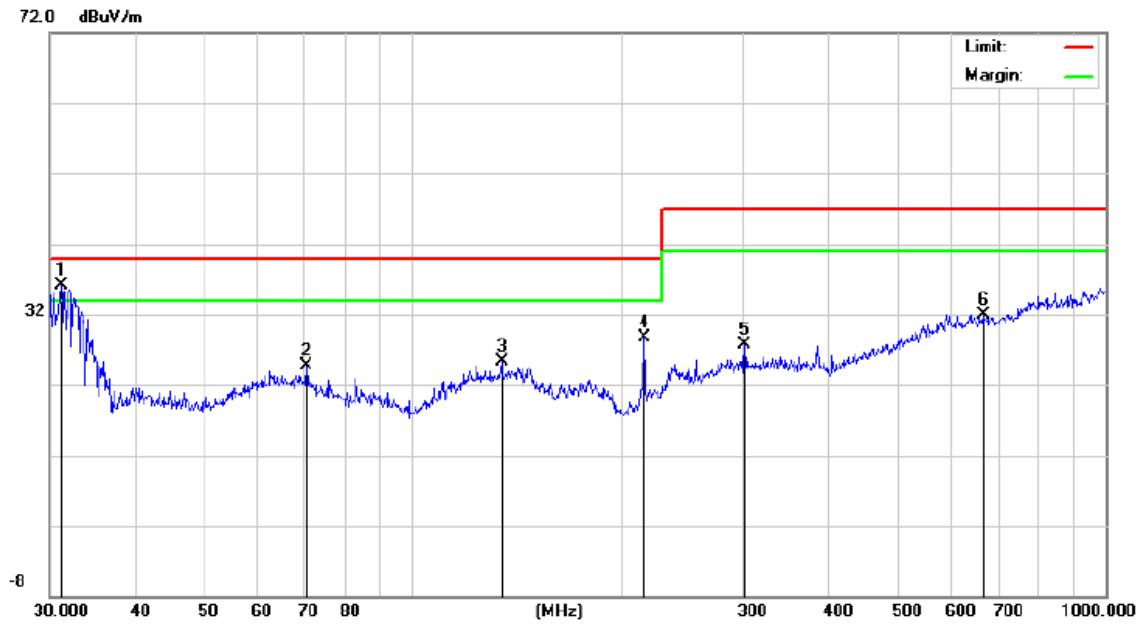

No.	Mk.	Freq. MHz	Reading Level dBuV	Correct Factor dB	Measure- ment dBuV/m	Limit dBuV/m	Over dB	Detector
1	*	31.1798	22.85	13.21	36.06	40.00	-3.94	peak
2		70.3365	6.64	18.04	24.68	40.00	-15.32	peak
3		134.5592	6.14	19.16	25.30	40.00	-14.70	peak
4		216.0240	12.88	15.81	28.69	40.00	-11.31	peak
5		301.4224	7.16	20.46	27.62	47.00	-19.38	peak
6		665.8035	5.85	26.08	31.93	47.00	-15.07	peak

**RESULT: PASS**

Any report having not been signed by authorized approver, or having been altered without authorization, or having not been stamped by the "Dedicated Testing/Inspection Stamp" is deemed to be invalid. Copying or excerpting portion of, or altering the content of the report is not permitted without the written authorization of AGC. The test results presented in the report apply only to the tested sample. Any objections to report issued by AGC should be submitted to AGC within 15days after the issuance of the test report. Further enquiry of validity or verification of the test report should be addressed to AGC by agc01@agccert.com.

## 10 EN 61000-4-2 ESD IMMUNITY TEST

### ELECTROSTATIC DISCHARGE (ESD) IMMUNITY TEST

<b>Port</b>	Enclosure
<b>Basic Standard</b>	EN 61000-4-2
<b>Test Level</b>	±8.0 kV (Air Discharge) ±4.0 kV (Contact Discharge) ±4.0 kV (Indirect Discharge)
<b>Standard require</b>	B
<b>Temperature</b>	24.7°C
<b>Humidity</b>	54.3% RH

#### 10.1 BLOCK DIAGRAM OF TEST SETUP

(The 470 k ohm resistors are installed per standard requirement)

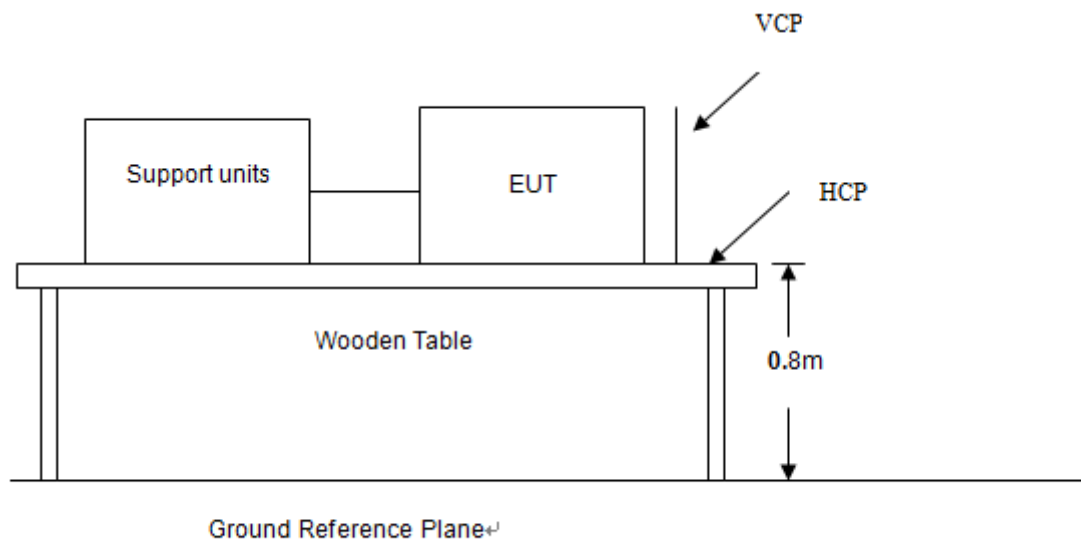

Any report having not been signed by authorized approver, or having been altered without authorization, or having not been stamped by the "Dedicated Testing/Inspection Stamp" is deemed to be invalid. Copying or excerpting portion of, or altering the content of the report is not permitted without the written authorization of AGC. The test results presented in the report apply only to the tested sample. Any objections to report issued by AGC should be submitted to AGC within 15days after the issuance of the test report. Further enquiry of validity or verification of the test report should be addressed to AGC by [agc01@agccert.com](mailto:agc01@agccert.com).

## 10.2 TEST PROCEDURE

The EUT was located 0.1 m minimum from all side of the HCP.

The support units were located 1 m minimum away from the EUT.

EUT worked with resistance load, and make sure EUT worked normally.

Active the communication function if the EUT with such port(s).

As per the requirement of EN 61000-4-2; applying direct contact discharge at the sides other than front of EUT at minimum 20 discharges (10 positive and 10 negative) if applicable, can't be applied direct contact discharge side of EUT then the indirect discharge shall be applied. One of the test points shall be subjected to at least 50 indirect discharge (contact) to the front edge of horizontal coupling plane.

Other parts of EUT where it is not possible to perform contact discharge then selecting appropriate points of EUT for air discharge, a minimum of 10 single air discharges shall be applied.

The application of ESD to the contact of open connectors is not required.

Putting a mark on EUT to show tested points. The following test condition was followed during the tests.

**Note:** As per the A2 to EN 61000-4-2, a bleed resistor cable is connected between the EUT and HCP during the test.

The electrostatic discharges were applied as follows:

Voltage	Coupling	Test Performance	Result
±4kV	Contact Discharge	No function loss	A
±4kV	Indirect Discharge HCP (Front)	No function loss	A
±4kV	Indirect Discharge HCP (Back)	No function loss	A
±4kV	Indirect Discharge HCP (Left)	No function loss	A
±4kV	Indirect Discharge HCP (Right)	No function loss	A
±4kV	Indirect Discharge VCP (Front)	No function loss	A
±4kV	Indirect Discharge VCP (Back)	No function loss	A
±4kV	Indirect Discharge VCP (Left)	No function loss	A
±4kV	Indirect Discharge VCP (Right)	No function loss	A
±8kV	Air Discharge	No function loss	A

### 10.3 PERFORMANCE & RESULT

<b>Criteria A:</b>	The apparatus continues to operate as intended. No degradation of performance or loss of function is allowed below a performance level specified by the manufacturer, when the apparatus is used as intended. In some cases the performance level may be replaced by a permissible loss of performance.
<b>Criteria B:</b>	The apparatus continues to operate as intended after the test. No degradation of performance or loss of function is allowed below a performance level specified by the manufacturer, when the apparatus is used as intended. In some cases the performance level may be replaced by a permissible loss of performance. During the test, degradation of performance is however allowed.
<b>Criteria C:</b>	Temporary loss of function is allowed, provided the functions self recoverable or can be restored by the operation of controls.

<input checked="" type="checkbox"/> <b>PASS</b> <input type="checkbox"/> <b>FAIL</b>
--------------------------------------------------------------------------------------

Any report having not been signed by authorized approver, or having been altered without authorization, or having not been stamped by the "Dedicated Testing/Inspection Stamp" is deemed to be invalid. Copying or excerpting portion of, or altering the content of the report is not permitted without the written authorization of AGC. The test results presented in the report apply only to the tested sample. Any objections to report issued by AGC should be submitted to AGC within 15days after the issuance of the test report. Further enquiry of validity or verification of the test report should be addressed to AGC by agc01@agccert.com.



### 11 EN 61000-4-3 RS IMMUNITY TEST

#### RADIATED ELECTROMAGNETIC FIELD IMMUNITY TEST

<b>Port</b>	Enclosure
<b>Basic Standard</b>	EN 61000-4-3
<b>Test Level</b>	3V/m with 80% AM. 1kHz Modulation at 80-1000MHz 3V/m with 80% AM. 1kHz Modulation at 1400-6000MHz
<b>Standard require</b>	A
<b>Temperature</b>	25.6°C
<b>Humidity</b>	56.5% RH

#### 11.1 BLOCK DIAGRAM OF TEST SETUP

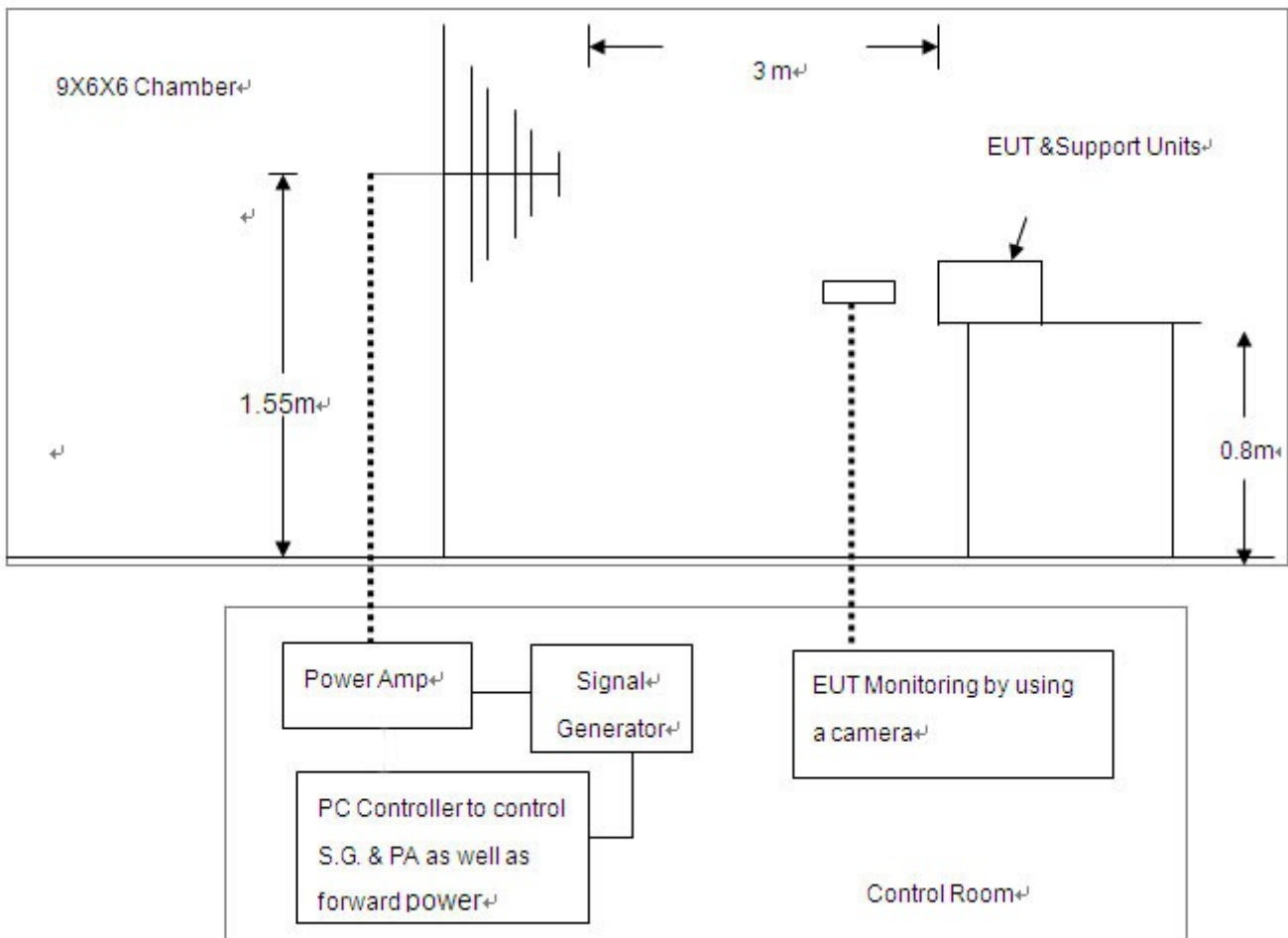

Any report having not been signed by authorized approver, or having been altered without authorization, or having not been stamped by the "Dedicated Testing/Inspection Stamp" is deemed to be invalid. Copying or excerpting portion of, or altering the content of the report is not permitted without the written authorization of AGC. The test results presented in the report apply only to the tested sample. Any objections to report issued by AGC should be submitted to AGC within 15days after the issuance of the test report. Further enquiry of validity or verification of the test report should be addressed to AGC by agc01@agccert.com.

## 11.2 TEST PROCEDURE

The EUT was located at the edge of supporting table keep 3 meter away from transmitting antenna, it just the calibrated square area of field uniformity. The support units were located outside of the uniformity area, but the cable(s) connected with EUT were exposed to the calibrated field as per EN 61000-4-3.

EUT worked with resistance load, and make sure EUT worked normally.

Setting the testing parameters of RS test software per EN 61000-4-3.

From the result of pre-test in step 5, choose the worst side of EUT for final test from 80 MHz to 1000 MHz and 1400MHz to 6000MHz at 1% steps.

Recording the test result in following table.

Test level: 3V/m

Steps: 1 % of fundamental

Dwell Time: 1 sec

Range (MHz)	Field	Modulation	Polarity	Position	Result
80-1000	3V/m	AM	H	Front	A
80-1000	3V/m	AM	H	Left	A
80-1000	3V/m	AM	H	Back	A
80-1000	3V/m	AM	H	Right	A
80-1000	3V/m	AM	V	Front	A
80-1000	3V/m	AM	V	Left	A
80-1000	3V/m	AM	V	Back	A
80-1000	3V/m	AM	V	Right	A

Any report having not been signed by authorized approver, or having been altered without authorization, or having not been stamped by the "Dedicated Testing/Inspection Stamp" is deemed to be invalid. Copying or excerpting portion of, or altering the content of the report is not permitted without the written authorization of AGC. The test results presented in the report apply only to the tested sample. Any objections to report issued by AGC should be submitted to AGC within 15days after the issuance of the test report. Further enquiry of validity or verification of the test report should be addressed to AGC by [agc01@agccert.com](mailto:agc01@agccert.com).

Attestation of Global Compliance(Shenzhen)Co., Ltd

Attestation of Global Compliance(Shenzhen)Std & Tech Co., Ltd

Tel: +86-755 2523 4088 E-mail: [agc@agccert.com](mailto:agc@agccert.com) Web: <http://www.agccert.com/>

Test level: 3V/m

Steps: 1 % of fundamental

Dwell Time: 1 sec

Range (MHz)	Field	Modulation	Polarity	Position	Result
1400-6000	3V/m	AM	H	Front	A
1400-6000	3V/m	AM	H	Left	A
1400-6000	3V/m	AM	H	Back	A
1400-6000	3V/m	AM	H	Right	A
1400-6000	3V/m	AM	V	Front	A
1400-6000	3V/m	AM	V	Left	A
1400-6000	3V/m	AM	V	Back	A
1400-6000	3V/m	AM	V	Right	A

### 11.3 PERFORMANCE & RESULT

<b>Criteria A:</b>	The apparatus continues to operate as intended. No degradation of performance or loss of function is allowed below a performance level specified by the manufacturer, when the apparatus is used as intended. In some cases the performance level may be replaced by a permissible loss of performance.
<b>Criteria B:</b>	The apparatus continues to operate as intended after the test. No degradation of performance or loss of function is allowed below a performance level specified by the manufacturer, when the apparatus is used as intended. In some cases the performance level may be replaced by a permissible loss of performance. During the test, degradation of performance is however allowed.
<b>Criteria C:</b>	Temporary loss of function is allowed, provided the functions self recoverable or can be restored by the operation of controls.

<input checked="" type="checkbox"/> <b>PASS</b> <input type="checkbox"/> <b>FAIL</b>
--------------------------------------------------------------------------------------

Any report having not been signed by authorized approver, or having been altered without authorization, or having not been stamped by the "Dedicated Testing/Inspection Stamp" is deemed to be invalid. Copying or excerpting portion of, or altering the content of the report is not permitted without the written authorization of AGC. The test results presented in the report apply only to the tested sample. Any objections to report issued by AGC should be submitted to AGC within 15days after the issuance of the test report. Further enquiry of validity or verification of the test report should be addressed to AGC by agc01@agccert.com.

## APPENDIX A: PHOTOGRAPHS OF TEST SETUP

### EN IEC 61000-6-3 RADIATED EMISSION TEST SETUP

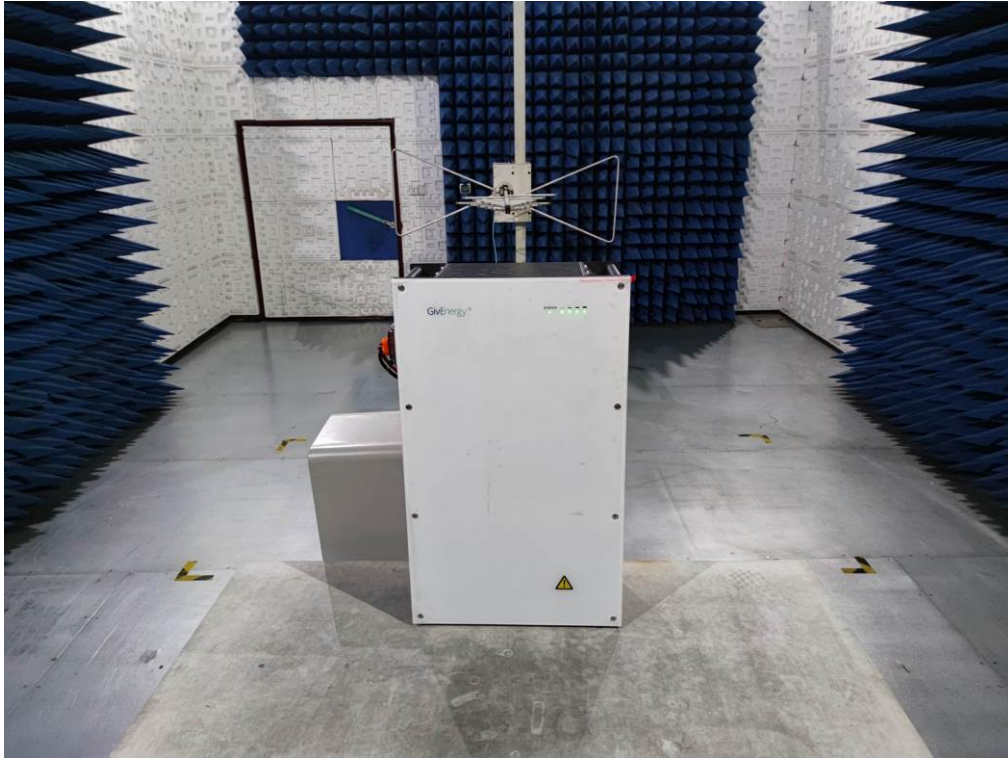

### EN 61000-4-2 ESD IMMUNITY TEST SETUP



Any report having not been signed by authorized approver, or having been altered without authorization, or having not been stamped by the “Dedicated Testing/Inspection Stamp” is deemed to be invalid. Copying or excerpting portion of, or altering the content of the report is not permitted without the written authorization of AGC. The test results presented in the report apply only to the tested sample. Any objections to report issued by AGC should be submitted to AGC within 15days after the issuance of the test report. Further enquiry of validity or verification of the test report should be addressed to AGC by [agc01@agccert.com](mailto:agc01@agccert.com).

Attestation of Global Compliance(Shenzhen)Co., Ltd

Attestation of Global Compliance(Shenzhen)Std & Tech Co., Ltd

Tel: +86-755 2523 4088 E-mail: [agc@agccert.com](mailto:agc@agccert.com) Web: <http://www.agccert.com/>

## EN 61000-4-3 RS IMMUNITY TEST SETUP

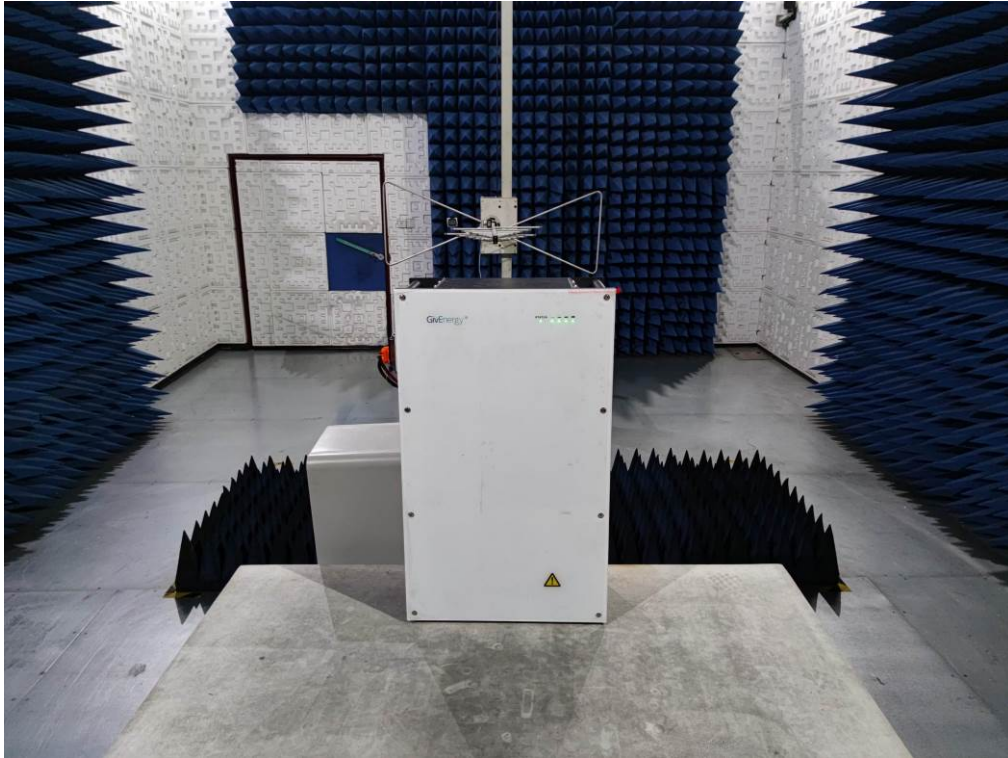

Any report having not been signed by authorized approver, or having been altered without authorization, or having not been stamped by the “Dedicated Testing/Inspection Stamp” is deemed to be invalid. Copying or excerpting portion of, or altering the content of the report is not permitted without the written authorization of AGC. The test results presented in the report apply only to the tested sample. Any objections to report issued by AGC should be submitted to AGC within 15days after the issuance of the test report. Further enquiry of validity or verification of the test report should be addressed to AGC by [agc01@agccert.com](mailto:agc01@agccert.com).

Attestation of Global Compliance(Shenzhen)Co., Ltd

Attestation of Global Compliance(Shenzhen)Std & Tech Co., Ltd

Tel: +86-755 2523 4088 E-mail: [agc@agccert.com](mailto:agc@agccert.com) Web: <http://www.agccert.com/>

## APPENDIX B: PHOTOGRAPHS OF EUT

TOP VIEW OF EUT



BOTTOM VIEW OF EUT

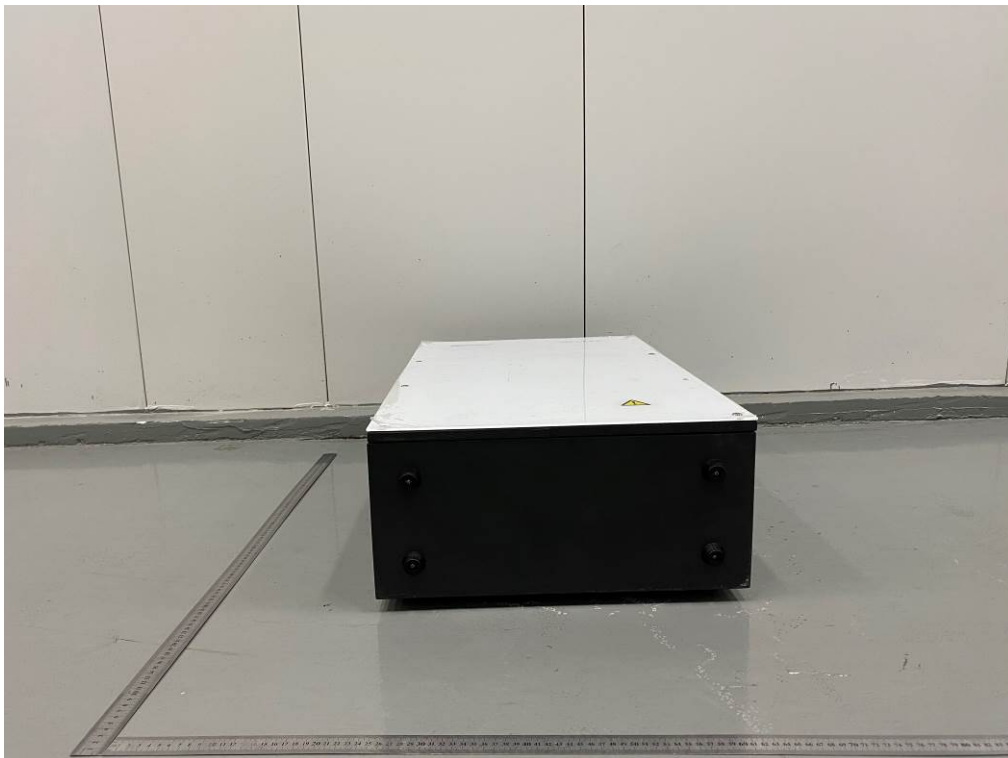

Any report having not been signed by authorized approver, or having been altered without authorization, or having not been stamped by the “Dedicated Testing/Inspection Stamp” is deemed to be invalid. Copying or excerpting portion of, or altering the content of the report is not permitted without the written authorization of AGC. The test results presented in the report apply only to the tested sample. Any objections to report issued by AGC should be submitted to AGC within 15days after the issuance of the test report. Further enquiry of validity or verification of the test report should be addressed to AGC by [agc01@agccert.com](mailto:agc01@agccert.com).

### FRONT VIEW OF EUT



### BACK VIEW OF EUT

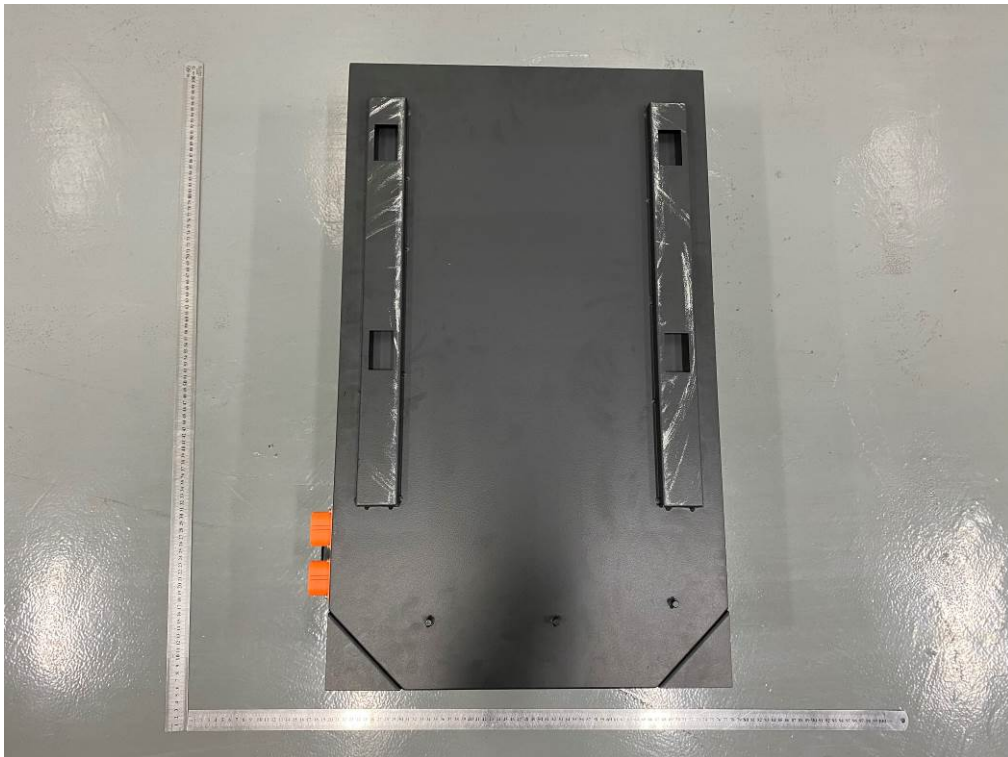

Any report having not been signed by authorized approver, or having been altered without authorization, or having not been stamped by the “Dedicated Testing/Inspection Stamp” is deemed to be invalid. Copying or excerpting portion of, or altering the content of the report is not permitted without the written authorization of AGC. The test results presented in the report apply only to the tested sample. Any objections to report issued by AGC should be submitted to AGC within 15days after the issuance of the test report. Further enquiry of validity or verification of the test report should be addressed to AGC by [agc01@agccert.com](mailto:agc01@agccert.com).

LEFT VIEW OF EUT



RIGHT VIEW OF EUT

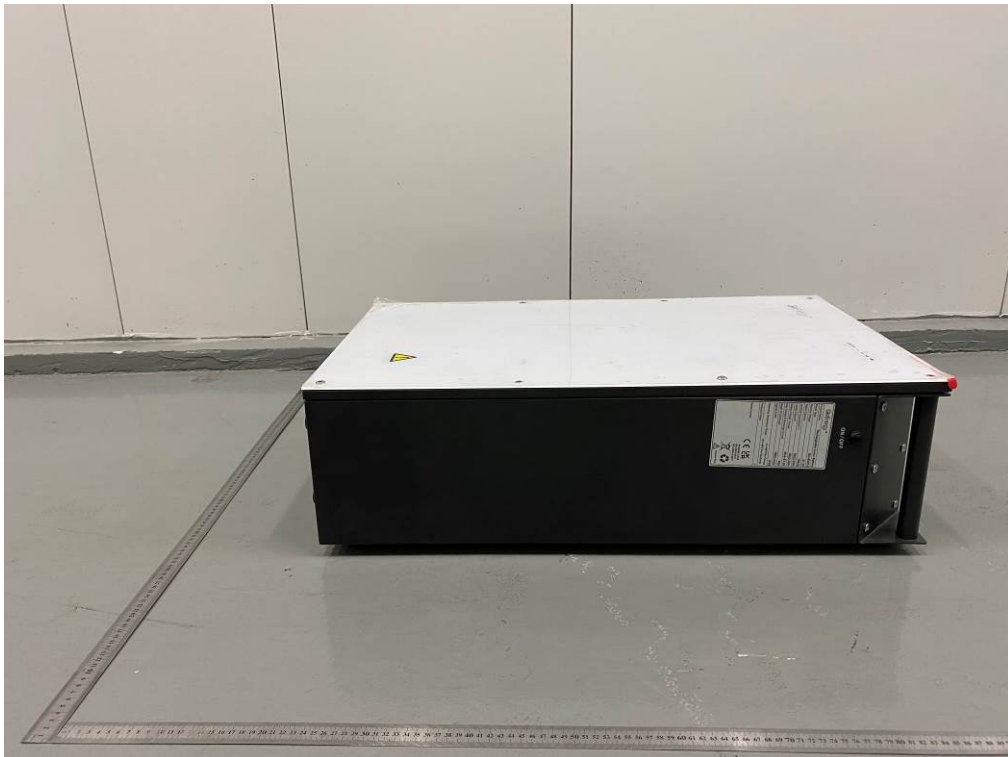

----END OF REPORT----

Any report having not been signed by authorized approver, or having been altered without authorization, or having not been stamped by the “Dedicated Testing/Inspection Stamp” is deemed to be invalid. Copying or excerpting portion of, or altering the content of the report is not permitted without the written authorization of AGC. The test results presented in the report apply only to the tested sample. Any objections to report issued by AGC should be submitted to AGC within 15days after the issuance of the test report. Further enquiry of validity or verification of the test report should be addressed to AGC by [agc01@agccert.com](mailto:agc01@agccert.com).

Attestation of Global Compliance(Shenzhen)Co., Ltd  
Attestation of Global Compliance(Shenzhen)Std & Tech Co., Ltd  
Tel: +86-755 2523 4088 E-mail: [agc@agccert.com](mailto:agc@agccert.com) Web: <http://www.agccert.com/>





## Conditions of Issuance of Test Reports

1. All samples and goods are accepted by the Attestation of Global Compliance (Shenzhen) Co., Ltd (the “Company”) solely for testing and reporting in accordance with the following terms and conditions. The company provides its services on the basis that such terms and conditions constitute express agreement between the company and any person, firm or company requesting its services (the “Clients”).
2. Any report issued by Company as a result of this application for testing services (the “Report”) shall be issued in confidence to the Clients and the Report will be strictly treated as such by the Company. It may not be reproduced either in its entirety or in part and it may not be used for advertising or other unauthorized purposes without the written consent of the Company. The Clients to whom the Report is issued may, however, show or send it, or a certified copy thereof prepared by the Company to its customer, supplier or other persons directly concerned. The Company will not, without the consent of the Clients, enter into any discussion or correspondence with any third party concerning the contents of the Report, unless required by the relevant governmental authorities, laws or court orders.
3. The Company shall not be called or be liable to be called to give evidence or testimony on the Report in a court of law without its prior written consent, unless required by the relevant governmental authorities, laws or court orders.
4. In the event of the improper use of the report as determined by the Company, the Company reserves the right to withdraw it, and to adopt any other additional remedies which may be appropriate.
5. Samples submitted for testing are accepted on the understanding that the Report issued cannot form the basis of, or be the instrument for, any legal action against the Company.
6. The Company will not be liable for or accept responsibility for any loss or damage however arising from the use of information contained in any of its Reports or in any communication whatsoever about its said tests or investigations.
7. Clients wishing to use the Report in court proceedings or arbitration shall inform the Company to that effect prior to submitting the sample for testing.
8. The Company is not responsible for recalling the electronic version of the original report when any revision is made to them. The Client assumes the responsibility to providing the revised version to any interested party who uses them.
9. Subject to the variable length of retention time for test data and report stored hereinto as otherwise specifically required by individual accreditation authorities, the Company will only keep the supporting test data and information of the test report for a period of six years. The data and information will be disposed of after the aforementioned retention period has elapsed. Under no circumstances shall we provide any data and information which has been disposed of after retention period. Under no circumstances shall we be liable for damage of any kind, including (but not limited to) compensatory damages, lost profits, lost data, or any form of special, incidental, indirect, consequential or punitive damages of any kind, whether based on breach of contract of warranty, tort (including negligence), product liability or otherwise, even if we are informed in advance of the possibility of such damages.

Any report having not been signed by authorized approver, or having been altered without authorization, or having not been stamped by the “Dedicated Testing/Inspection Stamp” is deemed to be invalid. Copying or excerpting portion of, or altering the content of the report is not permitted without the written authorization of AGC. The test results presented in the report apply only to the tested sample. Any objections to report issued by AGC should be submitted to AGC within 15 days after the issuance of the test report. Further enquiry of validity or verification of the test report should be addressed to AGC by [agc01@agccert.com](mailto:agc01@agccert.com).