

## INSTALLATION GUIDE

# ALL IN ONE + GIV-GATEWAY

GIV-AIO-13.5 | GIV-AIO-13.5-3.6 | GIV-AIO-GW1

**INTRODUCTION**

General Introduction	4
System Diagram	5

**ALL IN ONE INSTALLATION**

All in One Specifications	7
All in One Box Contents	8
All in One Components	9
All in One Unboxing	10
Installation Instructions	11
Safety Instructions	12
Clearance and Maintenance	13
All in One Step-by-Step Installation	14
All in One Connections Overview	16
All in One AC Utility grid Connection	17
All in One Comms Connection with Giv-Gateway	18
All in One Comms Connection without Giv-Gateway	19
GEM120CT Overview and Instructions	20

**GIV-GATEWAY INSTALLATION**

Giv-Gateway Specifications	22
Giv-Gateway Box Contents	23
Isolating the Main Supply to the Property	24
Giv-Gateway Components	25
Clearance and Maintenance	26
Giv-Gateway Step-by-Step Installation	27

**GIV-GATEWAY INSTALLATION CONT...**

Connections Overview	28
Giv-Gateway AC Utility Grid Connection	29
Giv-Gateway Wiring Connections	30
All in One Neutral Continuity	31
Giv-Gateway Communication Connections	32
Connecting All in One to Giv-Gateway	33

**CONFIGURATION**

Setting Up Monitoring	35
Enabling DRM Control	38
Adjust Power Quality Response Mode Setpoints	41
View Inverter Firmware and Settings	44
Generation Control & Export Control Settings	47
WiFi Guide	51
Commissioning and Decommissioning a System	55

**FUNDAMENTALS**

Understanding your All in One	57
Understanding your Giv-Gateway	58
All in One Installation with Giv-Gateway	59
All in One Installation without Giv-Gateway	60
Work Modes	61
Manufacturer Warranties	62

## Introduction

All information contained in this booklet refers to the installation and maintenance of GivEnergy's All in One and Giv-Gateway. Please retain this manual for future reference.

**Legal Disclaimer:** This document is the property of GivEnergy, reproduction is prohibited.

## Installation Requirements

Installation of the GivEnergy All in One and Giv-Gateway must be carried out by a **GivEnergy Approved Installer**, in accordance with local wiring regulations, and by a registered and qualified electrician.

## Unit Information

The All in One contains a bidirectional inverter and a 13.5kWh lithium iron phosphate battery. When used with our Giv-Gateway, the system can provide whole home backup when a power outage occurs. The system can charge from the grid when prices are cheaper, and export stored generation when prices are at their peak. The Giv-Gateway interface features connections for a PV inverter, EV charger, grid and home storage battery.

## Storing the All in One and Giv-Gateway

The unit must be stored in its original packaging at temperatures between -40°C - 70°C. Do not stack more than 5 units on top of each other.

## Packaging Contents

When unpacking, please check the following:

- ✔ There are no missing accessories from the packaging list
- ✔ The model and specification of the All in One and Giv-Gateway's nameplate match the order specifications
- ✔ Ensure the packaging and product are free from any damage

If any damaged or missing parts are found, please contact GivEnergy on 01377 252 874 or email [support@givenergy.co.uk](mailto:support@givenergy.co.uk) immediately and your distributor. Returns must be provided in the original or equivalent packaging. The Giv-Gateway's cardboard packaging is recyclable.

## With Giv-Gateway

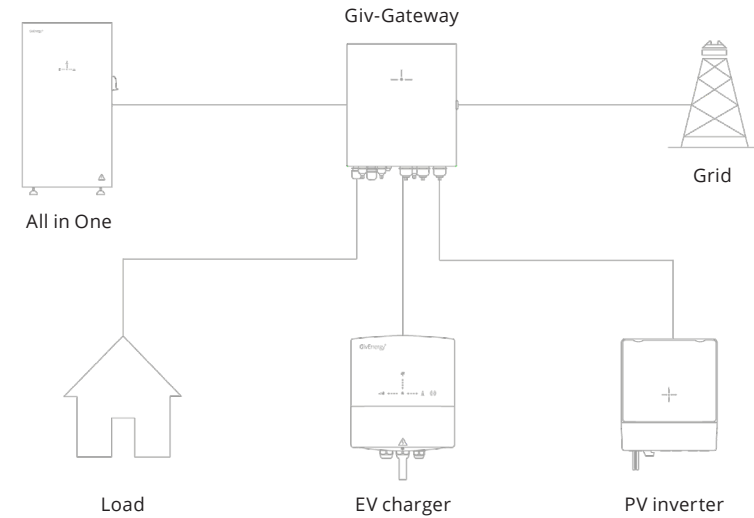

## Without Giv-Gateway

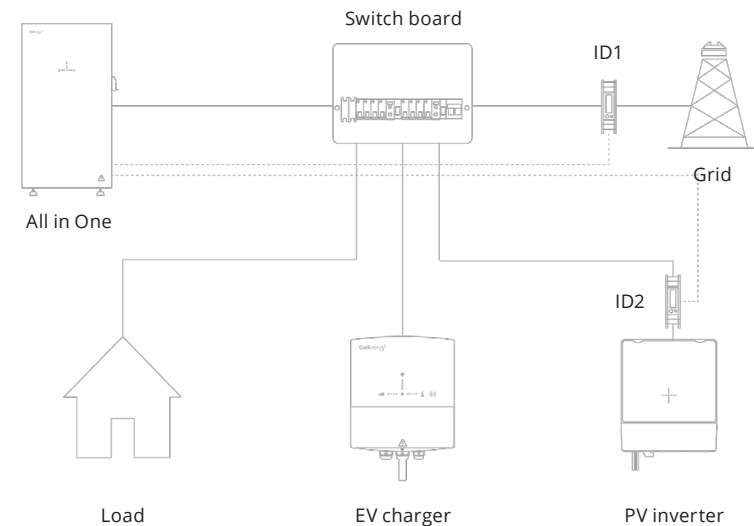



**ROBUST AND FLEXIBLE**

A great addition to any smart home

Primarily working as an on grid system, the All in One can deliver 7.2kW of peak power\* into the home on top of any solar generation.

Complete with a substantial 13.5kWh usable battery pack that stores excess generation. Featuring a modular design comprising 4 removable battery packs, allowing for ease of handling and installation.

**Specifications**

**Dimensions**

1100H x 280D x 600W (mm)

**Operating temperature**

-10°C to 50°C

**AC Max. Output Rating**

3.6kW / 16 A Peak/continuous  
7.2kW / 32A Peak/ 6kW / 27A continuous

**Weight**

173.7 Kg

**Depth of Discharge**

100%

**Noise Emission (typical)**

<30dB

**Connectivity**

WiFi, LAN and 4G

**Model numbers**

GIV-AIO-AC-13.5-3.6 + Giv-Gateway  
GIV-AIO-AC-13.5 + Giv-Gateway  
GIV-AIO-AC-13.5-3.6  
GIV-AIO-AC-13.5

**Environmental category**

Suitable for outdoor and indoor installations.

**Warranty**

12 years

**Environmental category**

Outdoor

**Ingress protection rating**

IP65

**Pollution degree**

2 (Giv-Gateway), 3 (All in One)

\* Peak power is for off grid operation) only

All in One  
Installation

## ALL IN ONE BOX CONTENTS

Item	Item Name	Qty
A	All in One Unit	1
B	Bracket	2
C	Expansion Bolt	4
D	WiFi Antenna	1
E	Spirit Level	1

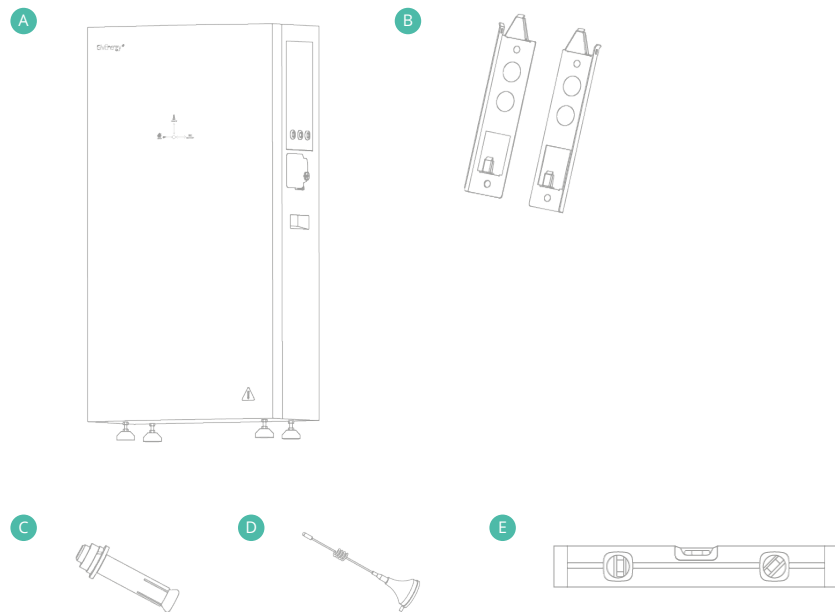

## ALL IN ONE COMPONENTS

Item	Item Name
A	Power Flow Indicator
B	AC Supply Terminals
C	WiFi Antenna
D	DC Circuit breaker
E	On / Off Switch
F	Cable entry point

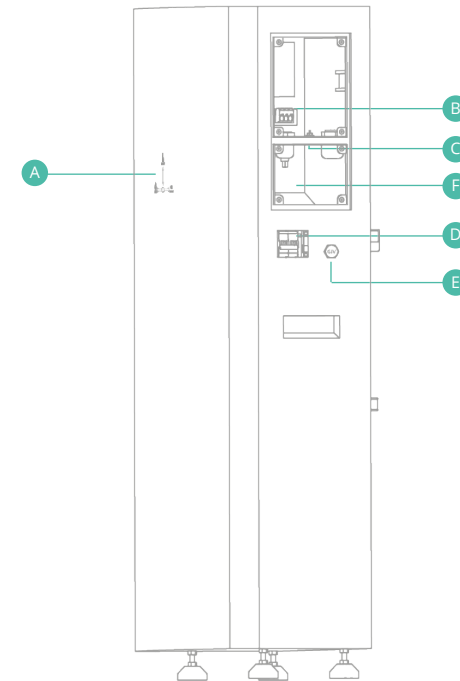

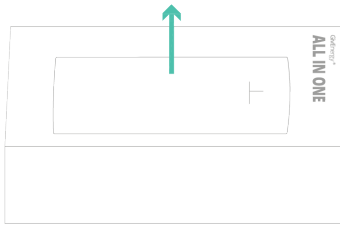

1. Remove top cover from the wooden crate, ensuring to wear gloves and taking care when bending the metal tabs.

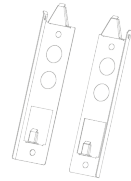

2. Remove the All in One brackets, template, and accessories and place to one side

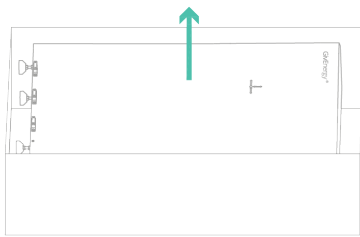

3. Remove the foam and then the front cover of the All in One

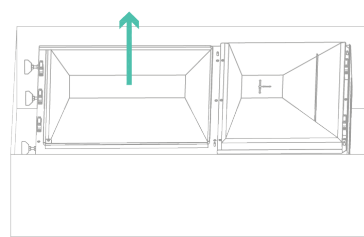

4. Remove bottom waterproof cover of the All in One

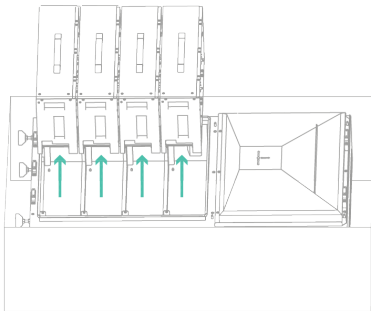

5. Remove the battery packs, leave to one side

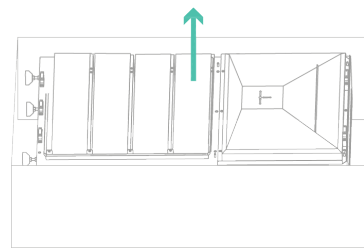

6. Remove All in One case from wooden crate (2 person lift)

## Dos



The system must be installed in an easily accessible location, the status display must be visible and not obstructed



Please ensure that the wall to be mounted on is sufficient enough to hold the weight of the All in One and Giv-Gateway (if fitted)



The system must be installed in a well ventilated area, the ambient temperature should be below 40°C to ensure optimal operation



The system must be installed vertically with connections always positioned at the bottom, never install horizontally, and avoid tilting the unit



The system must be installed under a canopy if installing externally unless fully shaded



The feet of the All in One are designed to be above the frost-line at a minimum of 50mm



You must comply with local battery and inverter installation guidelines and regulations

## Don'ts



Do not use the system if the temperature exceeds 45°C



Do not install in direct sunlight or near water sources



Do not use the equipment if there are any deformities, such as bulging or leakages



Do not puncture the equipment



Do not throw the equipment or use forceful impact



Do not attempt to repair the equipment yourself (please call your Approved Installer)

Extra care and attention must be taken when installing and maintaining any GivEnergy equipment. The system is capable of retaining a high voltage, even when disconnected.

- If you suspect something is wrong with the system, contact GivEnergy on 01377 252 874 or email [support@givenergy.co.uk](mailto:support@givenergy.co.uk).
- If any damaged or missing parts are found, please contact GivEnergy on 01377 252 874 or email [support@givenergy.co.uk](mailto:support@givenergy.co.uk) immediately. Returns must be provided in original or equivalent packaging, for safe transport please refer to our UN38.3 certificate
- All electrical installations must be carried out by a qualified and registered electrician and in accordance with the local wiring regulations
- During operation, the heat sink may become hot. Do not touch the heat sink at the sides, or the top of the inverter when in operation
- The system is designed to be connected to the grid; connecting your inverter to a generator or other power source can result in damage to the inverter or external devices and may invalidate your warranty
- All GivEnergy equipment must be installed by a GivEnergy approved installer
- Ensure all components are attached securely
- Ensure the All in One and Giv-Gateway are always fixed to the wall using the mounting bracket
- Any errors are shown with a red LED, for full descriptions please refer to the GivEnergy monitoring portal

### Space Clearance

There must be adequate clearance around the All in One to allow for heat dissipation. The diagram below illustrates the space required around the system.



### Maintenance

When maintaining and cleaning the All in One, the whole system must be powered down. Please refrain from using cleaning products on the surface of the All in One. Ensure that the heat sink is free from blockage to allow proper air flow. Check that no cables, isolation points, or the casing itself are physically damaged.

To ensure your All in One operates optimally at all times, annual maintenance checks need to be carried out. Check for visible damage or discolouration of the switch, and that the cables are intact. Please ensure that the top of the All in One is not obstructed in any way.

## ALL IN ONE STEP-BY-STEP INSTALLATION

**Step 1:** Place the wall mounting template horizontally onto the wall and mark the position of the bracket holes. Drill 4 holes at the marked positions, at least 75mm deep.

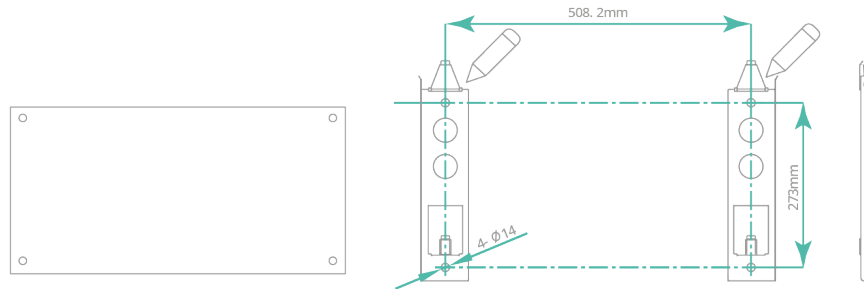

**Step 2:** Fix the mounting bracket to the wall using the expansion bolts or suitable fixings.

**Please note:** The brackets are sided.

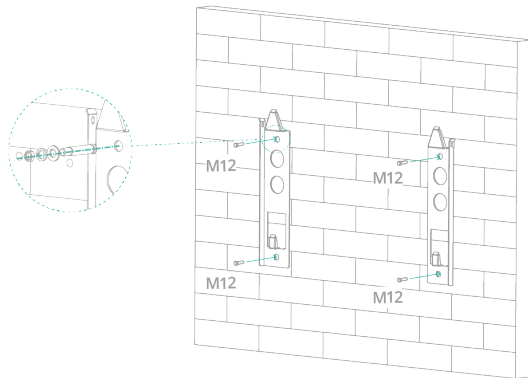

## ALL IN ONE STEP-BY-STEP INSTALLATION

**Step 3:** Mount the All in One onto the mounting bracket. Adjust the height of the supporting feet to ensure the unit is level and attach the securing screws to the brackets, ensuring the weight is on the feet, not the brackets.

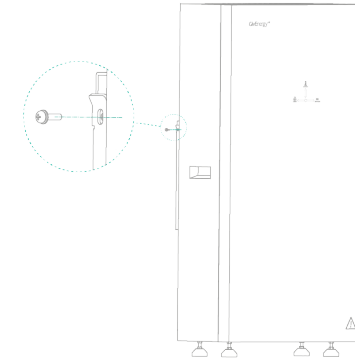

**Step 4:** Re-insert the battery modules into the shelves of the All in One battery compartment. Secure the battery modules using the fixings provided. Re-attach waterproof cover.

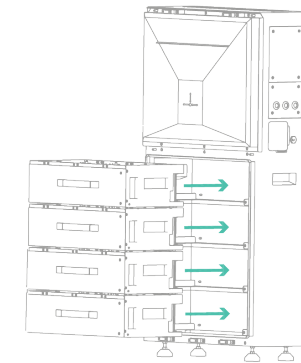

**Step 5:** Reverse steps 1 & 2 and use the screws / fixings originally removed.



## ALL IN ONE CONNECTIONS OVERVIEW

Item	Item Name
A	Communication / network ports
B	AC Supply

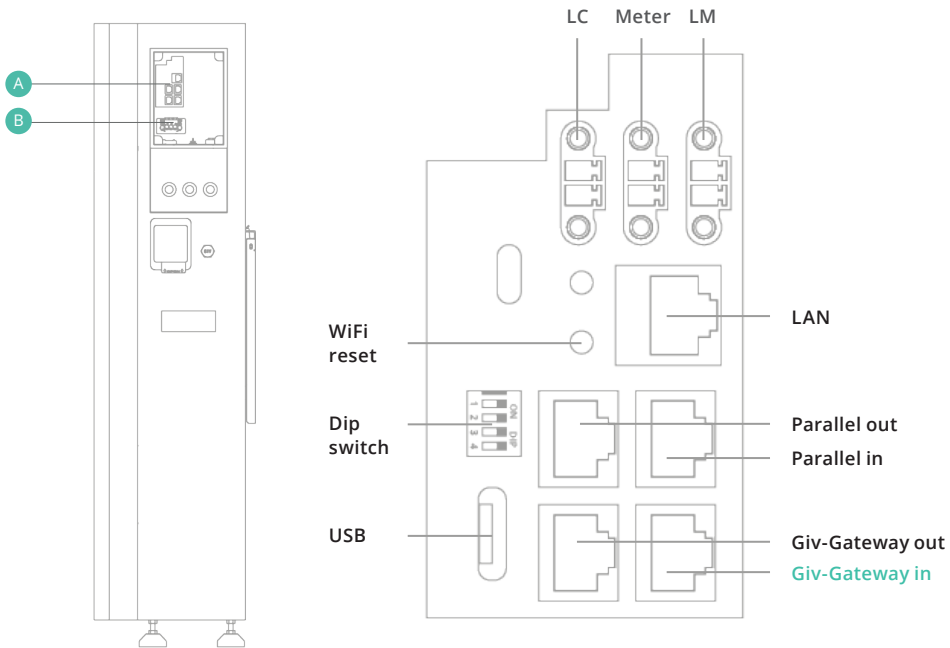

All in One communication / network ports

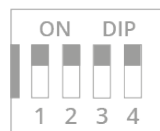

WiFi

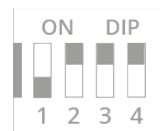

LAN

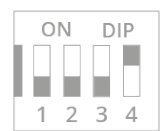

USB (Dongle) Mode

## ALL IN ONE AC UTILITY GRID CONNECTION

If installing using the Giv-Gateway, the RCD is already included. If being installed without the Giv-Gateway, the installer will need to source their own RCD / protection device and ensure that the current rating is suitable for the installation.

Cable size requirements are dependent on the country of installation, cable run length, and mix. current of the product.

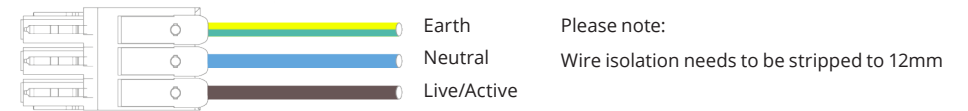

Both side and rear cable entry points are provided. If using rear entry point, please ensure the cable is installed prior to fitting the All in One. The AC supply cable should enter through one of the waterproof glands, and pass through the cable entry chamber (labelled below), and connected into the AC supply plug. Strip the outer insulation to 12mm in length of bare copper and connect them to the plug (instructions are on the side of the plug).

The recommended maximum cable length should not exceed 50m as the resistance of the cable will consume inverter output power and reduce the inverter efficiency.

The main earth connection in the AC connection plug bonds to the chassis and external metallic parts when inserted into the AC connection port.

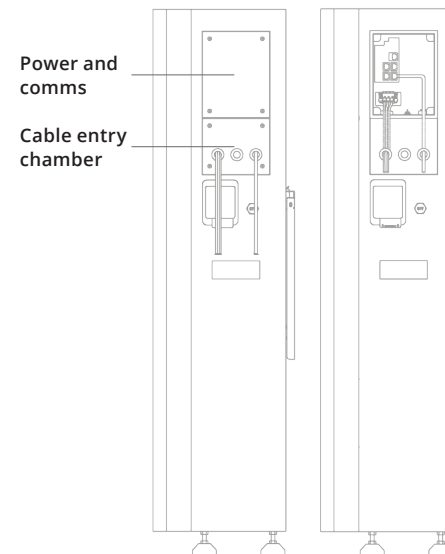

**!** The AIO/Giv-Gateway is a Class I protective product, so its enclosure is to be grounded to ensure personal safety. This is achieved by connecting the earthing(PE) wire from grid to the PE busbar in Giv-Gateway and then/or in case of no Giv-Gateway, the AIO's PE terminal on its AC terminal block. The PE terminal on AIO and Giv-Gateway has direct and good contact with their respective metal enclosure.

Type A RCD with 30mA tripping setting is already integrated in Giv-Gateway. For standalone version AIO, a Type A RCD with 30mA tripping current is recommended to be used.

# ALL IN ONE COMMS CONNECTION WITH GIV-GATEWAY

# ALL IN ONE COMMS CONNECTION WITHOUT GIV-GATEWAY

## Single All in One installation

To install a single All in One, connect the communication wire to the socket D in the wiring compartment of the All in One.

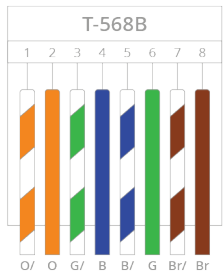
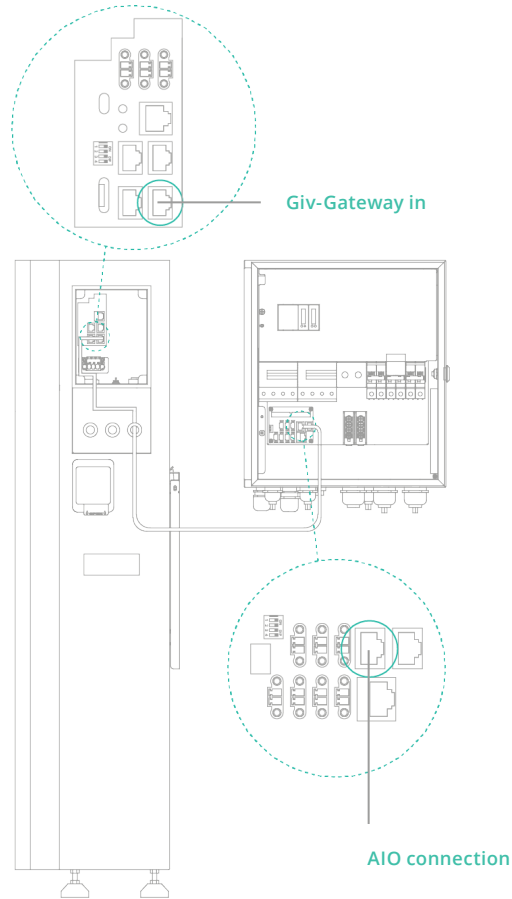

! The communication cable must be terminated with a RJ45 plug at either end to connect the All in One to the Giv-Gateway. Ensure the wiring configuration into the RJ45 is the same both ends, a cross-over cable will not work. A standard Ethernet Cat5/6 cable will suffice here, wired to T-568B standard if doing locally.

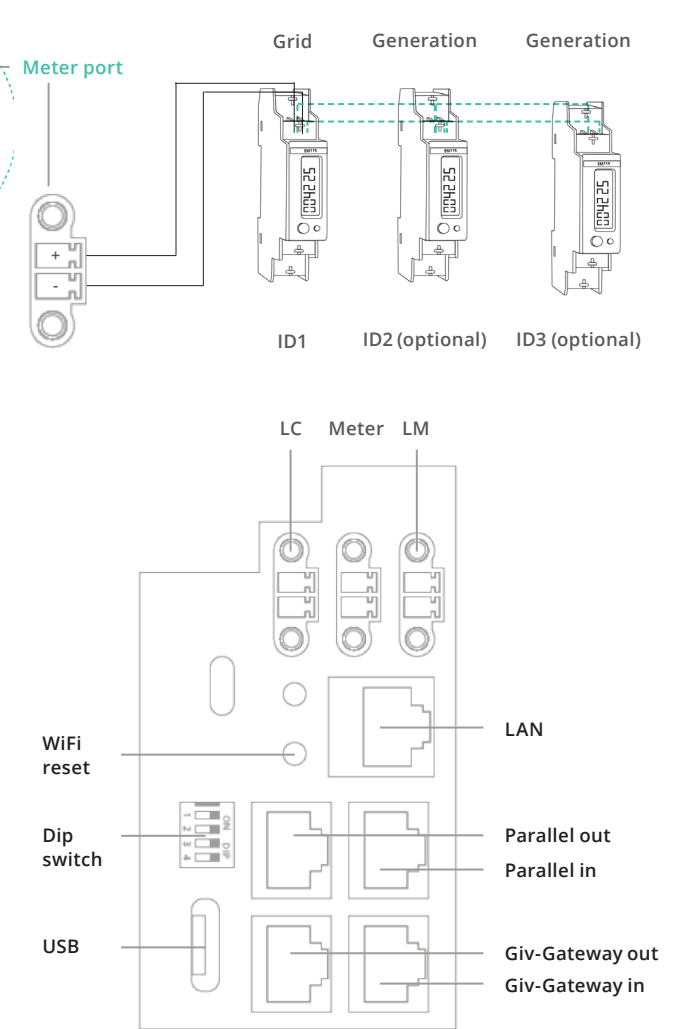

! We suggest that a twisted pair shielded cable is to be used for meter communication to lessen the risk of interference from external factors.

## GEM120CT OVERVIEW AND INSTRUCTIONS

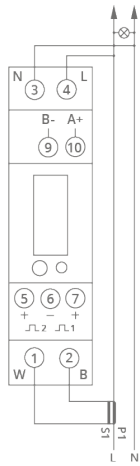

### Technical Specifications

Model Number	GEM-CT-45/100
Dimensions (HxWxD)	119 x 17.5 x 62mm
Working Temperature	-25°C ~ 55°C
Protection Class	IP51
Display	LCD

### Metering

Every system will need at least 1 GEM120 (ID1) meter installing to monitor the import and export of the building. Every GEM120 meter needs a power supply/voltage reference point.

**This could be a dedicated supply from a 6A, for example.**

Every GEM120 meter will need a data connection back to the inverter's meter communication port. Please see the previous page for the connection point.

**Data connection should be a twisted pair cable, for example, Belden multi-stranded cable.**

If installing multiple meters, both the data and power supply can be linked together in series.

GEM120 meters come with a split core CT that has a 2m cable.

**This must not be cut down or extended.**

Press and hold the GEM120CT button to change the ID settings.

**Please note:** the GEM120CT meter is only to be installed for a standalone All in One, the Giv-Gateway already includes a pre-installed GEM120CT.

# Giv-Gateway Installation



**WHOLE HOME BACKUP**  
A great companion to the AIO

By purchasing the additional Giv-Gateway, the All in One can provide whole house backup in the event of a grid failure.

The Giv-Gateway provides seamless switching between grid and battery ensuring that your property is always powered. The Giv-Gateway also facilitates a connection point for your solar PV system by allowing it to continue to generate energy even without a grid supply when in a grid outage scenario. Essential backup capacity varies dependent on model.

**Specifications**

**Dimensions**  
410H x 190D x 370W (mm)

**Nominal AC Power**  
18.4 kW

**Rated Grid Frequency**  
50/60±5Hz

**Protection Class**  
IP65

**Environmental category**  
Outdoor

**Pollution degree**  
Outside PD3; inside PD2

**Weight**  
12.75 Kg

**Max. AC Current**  
100A

**Warranty**  
12 years

**Model number**  
GIV-AIO-GW1

Item	Item Name	Qty
A	Giv-Gateway	1
B	Bracket	1
C	Mounting screw	2
D	Wall plug	2
E	Antenna	1
F	Key	1
G	M6 x 12 Bracket Screw	4

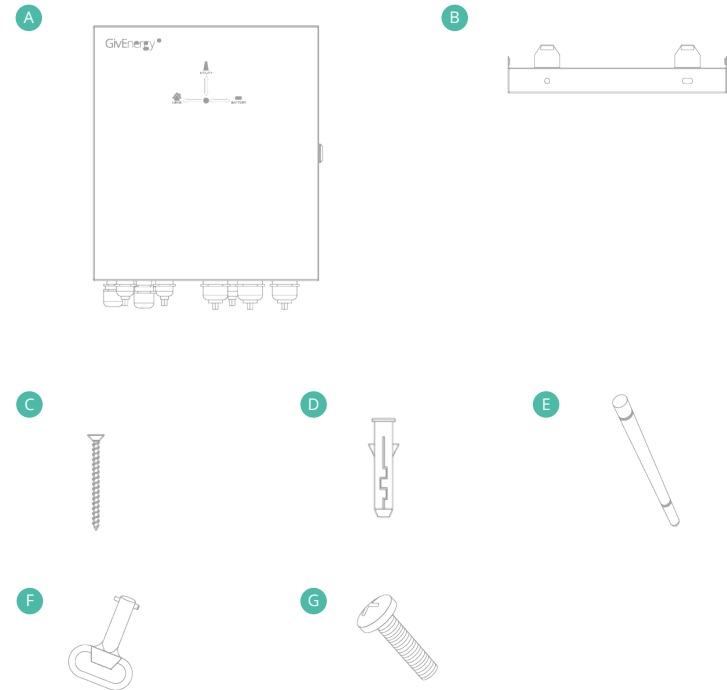

## ISOLATING THE MAIN SUPPLY TO THE PROPERTY

**Before installing the Giv-Gateway, make sure that the whole house is isolated from the main supply.**

Once isolated, please test to ensure that no voltage is present to the property before disconnecting the main supply cable from the main distribution/switch board. The Giv-Gateway should be installed between the customer's supply meter and the switch board.

## GIV-GATEWAY COMPONENTS

Item	Item Name
A	MCB, RCD
B	Grid / PV Meter and LoRa (spare)
C	CT, RS485, LAN, CAN, DRM

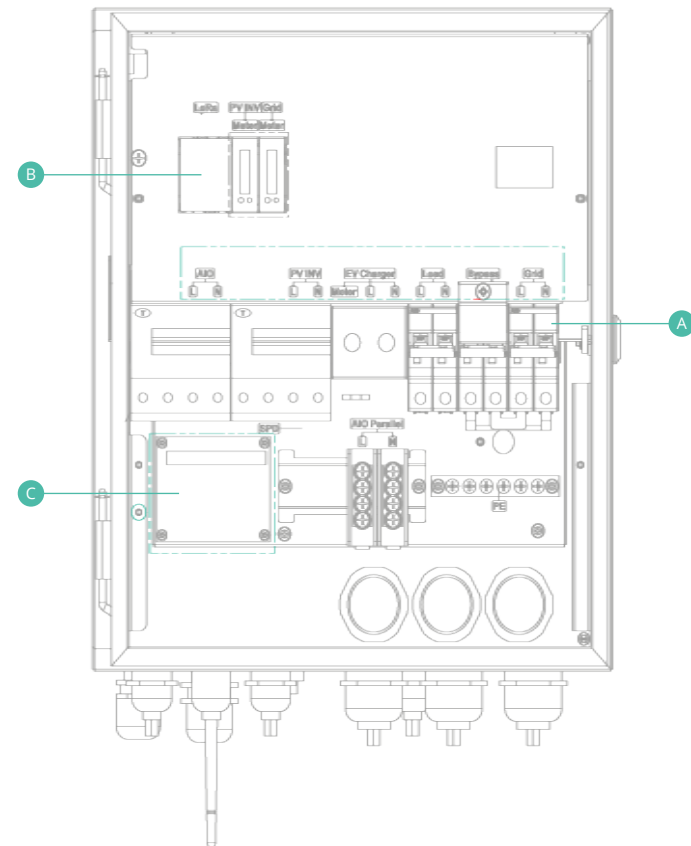

## Space Clearance

There must be adequate clearance around the Giv-Gateway. The diagram below illustrates the space required around the system.

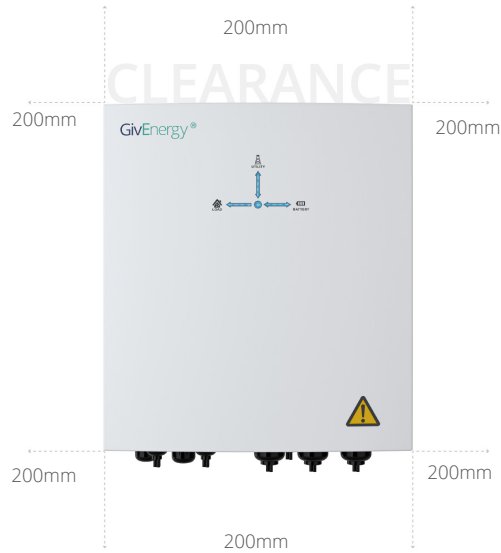

## Maintenance

When maintaining and cleaning the Giv-Gateway, please refrain from using cleaning products on its surface.

To ensure your Giv-Gateway operates optimally at all times, annual maintenance checks need to be carried out. Check for visible damage or discolouration of the switches, and that the cables are intact. Please ensure that the top of the Giv-Gateway is not obstructed in any way.

**Step 1:** Place the wall mounting bracket horizontally onto the wall and mark the position of the bracket holes. Drill 2 holes at the marked positions, at least 75mm deep.

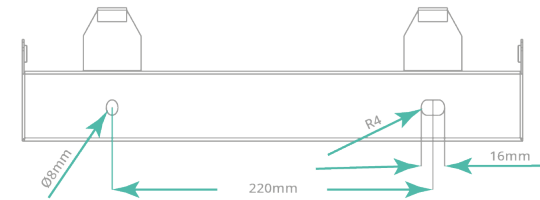

**Step 2:** Fix the mounting bracket to the wall using the fixings provided, or other suitable fixings.

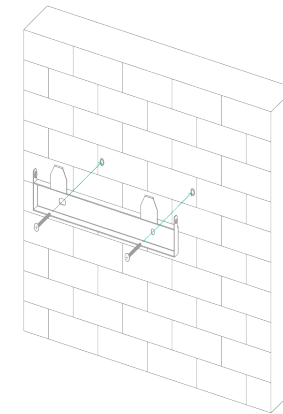

**Step 3:** Fix the Giv-Gateway to the mounting bracket and secure with the fixings provided. Ensure there is adequate clearance space.

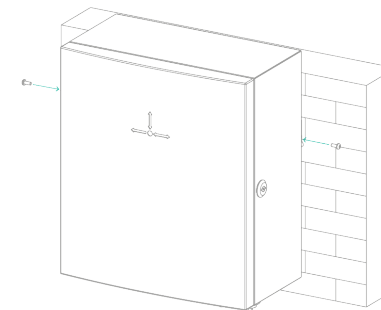

## CONNECTIONS OVERVIEW

Item	Item Name
A	LoRa connection Module (spare)
B	PV meter (ID2)
C	Grid meter (ID1)
D	Load (house supply)
E	AC supply (in)
F	All in One supply
G	PV inverter supply
H	EV charger (spare)
I	All in One parallel connection (coming soon)*
J	Grid bypass switch

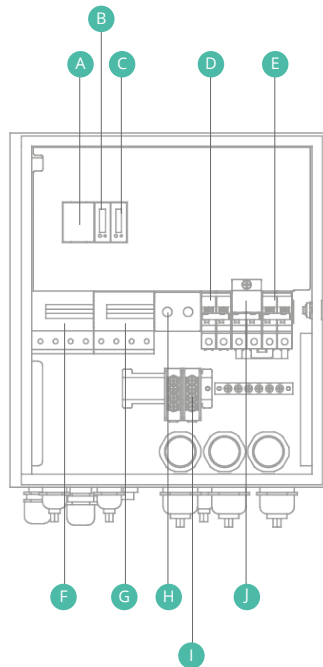

## GIV-GATEWAY AC UTILITY GRID CONNECTION

- **Breaker A - Single All in One connection**  
The power wires for All in One connection should be at least 6mm<sup>2</sup>. Strip the wire insulation for 8mm wiring connection.
- **Breaker B - PV inverter connection**  
PV can be fed directly from this breaker. Please ensure that the overcurrent protection is adequate for the installation. If retro fitting the AIO + Gateway to a solar system, you can leave the existing PV feed in situ and just use a monitoring clamp to read the generation.
- **Breaker C - EV charger connection**  
The maximum load current is 32A, so the load wires should be at least 6mm<sup>2</sup>. Strip the wire insulation for 8mm wiring connection.
- **Breaker D - Loads connection**  
The maximum load current is 80A, so the load wires should be at least 16mm<sup>2</sup>. Strip the wire insulation for 8mm to connect to this load breaker.
- **Breaker E - Bypass MCB**  
The bypass switch redirects grid power directly to the house, bypassing the Giv-Gateway.
- **Breaker F - Grid connection**  
The maximum grid current is 100A. The tails should be 25mm<sup>2</sup> or larger. If the existing tails are less than 25mm, Breaker F should be derated accordingly, Strip 8mm of insulation to connect to the Grid breaker.

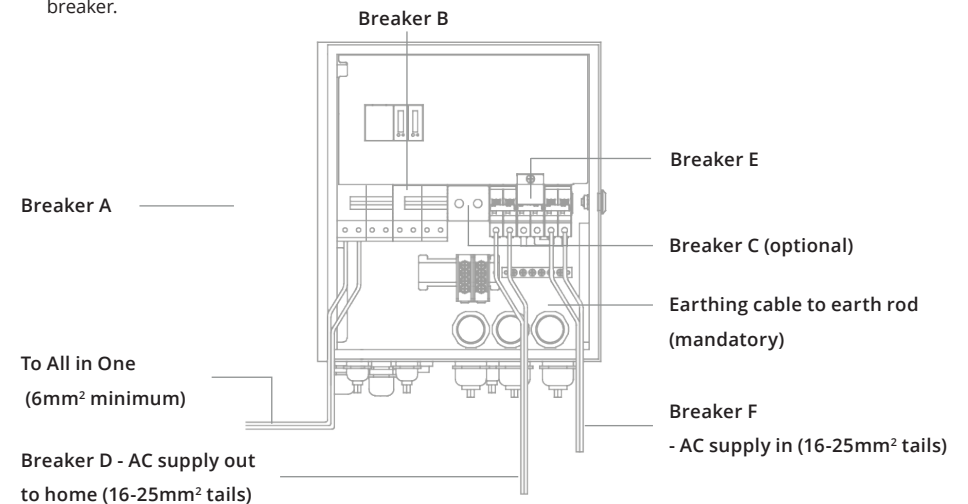

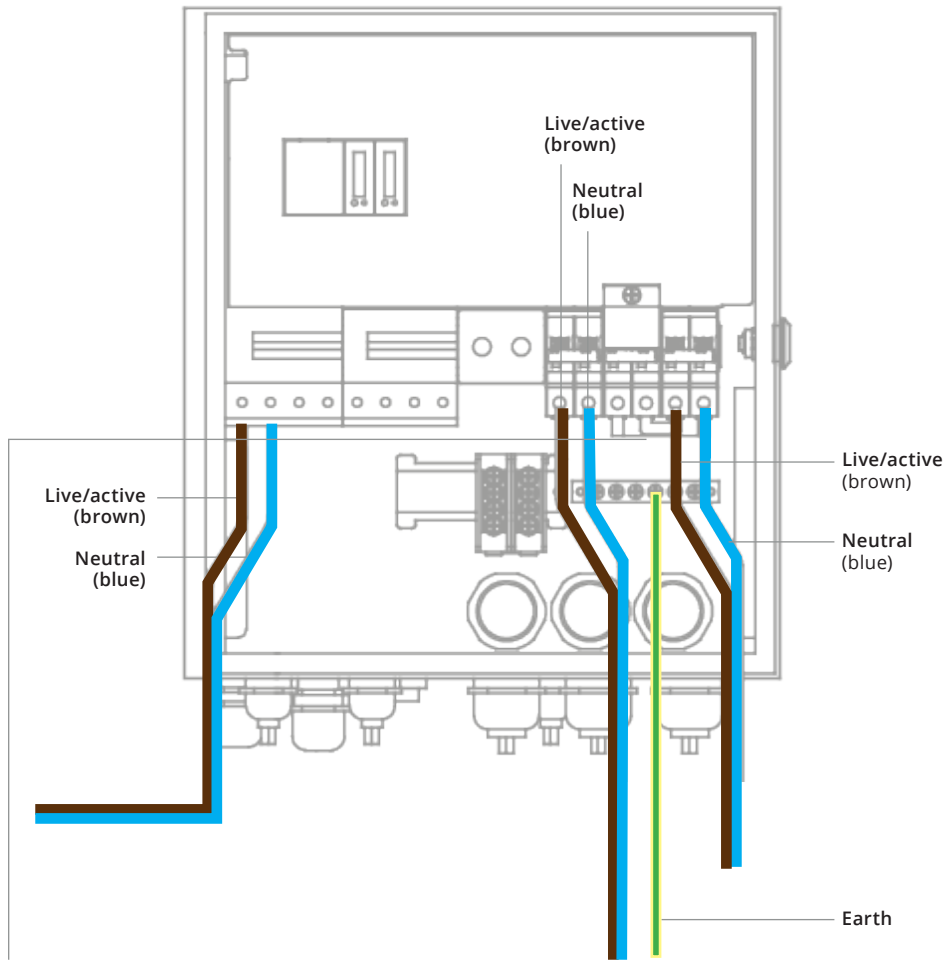

**Earthing cable to earth rod (mandatory)**

Please note: When using the earth terminal, this also earths the chassis and external metallic parts.

-  Earth (green/yellow)
-  Neutral (blue)
-  Live/Active (brown)

Type A RCD with 30mA tripping setting is already integrated in Giv-Gateway.

For standalone version AIO, a Type A RCD with 30mA tripping current is recommended to be used.

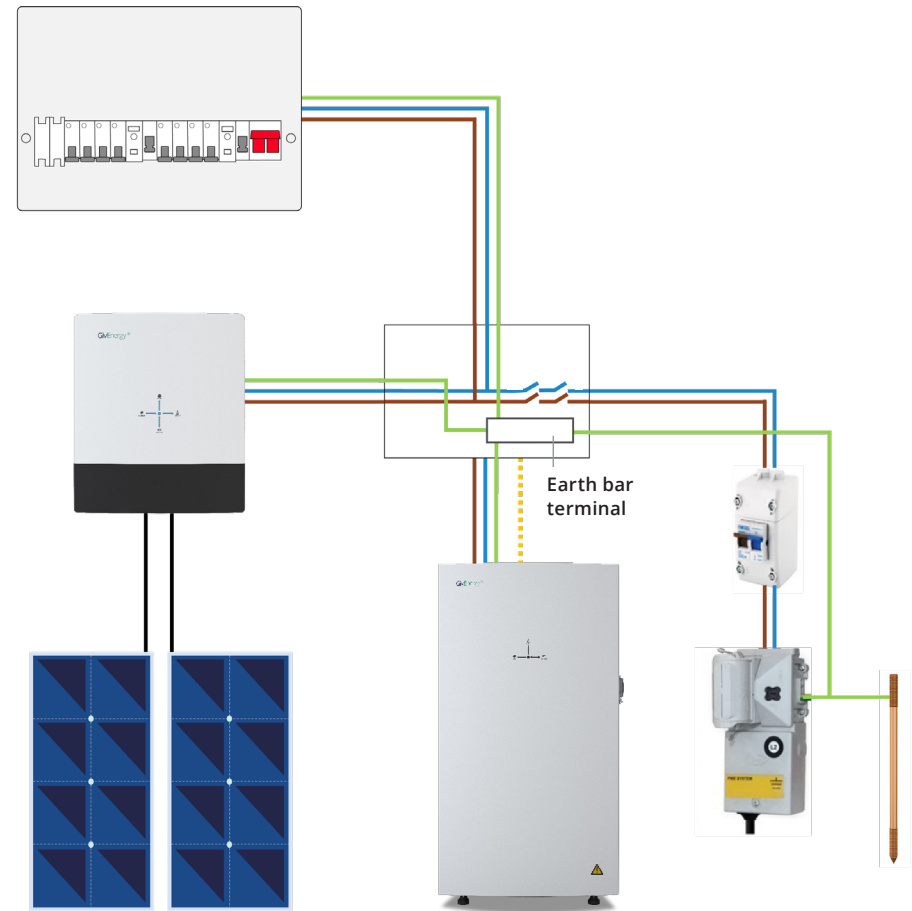

**Grid disconnect relay**

The Grid disconnect relay isolates both line conductors in the event of a power failure of the grid supply. The Earth is maintained at all times. Both the DNO earth and earth rod/disc are in parallel in accordance with BS7671, extract provided. In Island mode, the system adopts the TN-S earthing arrangement, as per the table below:

Connected mode earthing arrangement	Island mode earthing arrangement
TN-C-S	TN-S
TN-S	TN-S
TT	TN-S



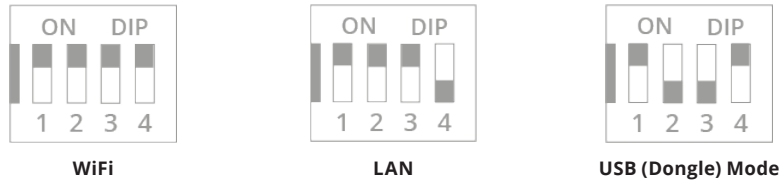

## Gateway communication/network ports

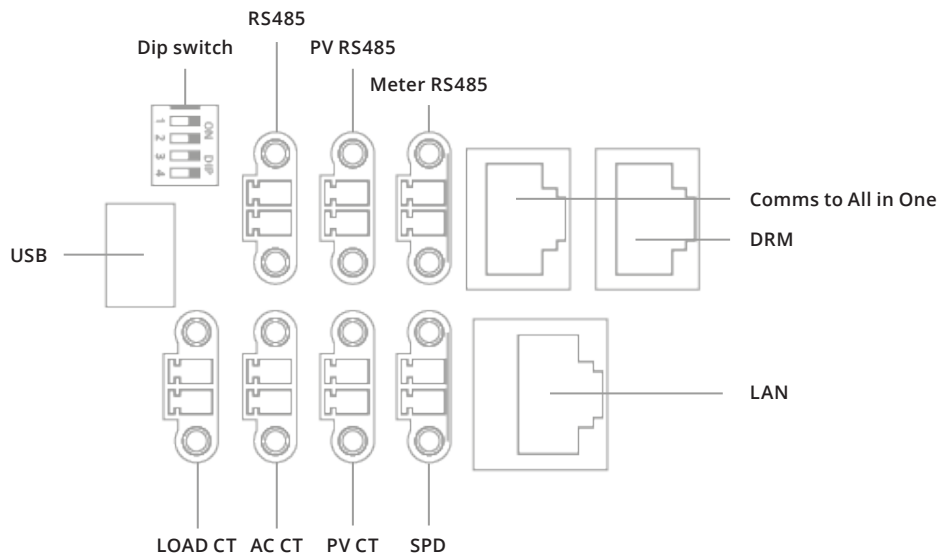

The meter tails between the meter position and the Giv-Gateway should not be longer than 3 metres. If the length is more than 3 metres, you should install an additional protective device at the nearest point to the supply inside the customer's premises, as specified in the current IEE Wiring Regulations.

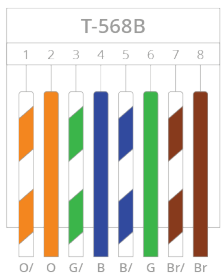

! The communication cable must be terminated with a RJ45 plug at either end to connect the All in One to the Giv-Gateway. Ensure the wiring configuration into the RJ45 is the same both ends, a cross-over cable will not work. A standard Ethernet Cat5/6 cable will suffice here, wired to T-568B standard if doing locally.

### AC supply wiring

! Remove bottom connections cover prior to wiring, and then replace once complete.

### Communication wiring

Once the equipment is assigned to the user during the commissioning process, the system will then connect to the **GivEnergy Monitoring Portal**. The inverter will report data to the GivEnergy Monitoring Portal, allowing information about the system to be displayed on the portal.

**Please allow up to 24 hours for the data to be read in accurately.**

Once the data is confirmed to be reading in correctly, the customer will be able to log in to their account via their device to manage and view their system.

For a more in-depth guide about our Monitoring Portal, please view our portal and app guide that is provided on our **Resource Hub** at [www.givenergy.co.uk](http://www.givenergy.co.uk).

*Please note: the GivEnergy app is supported by an active development team constantly working on updates and improvements. As such, app information is subject to change.*

## Accessing monitoring data on the Portal

**Step 1:** Log into the GivEnergy Monitoring Portal at [www.givenergy.cloud](http://www.givenergy.cloud).

**Step 2:** After logging in, you'll be taken to the Monitoring Portal Dashboard. From here, you can view information about your systems import/export data, solar forecasts, tariff savings, and much more.

To view in-depth information about your consumption, you can expand the graph in the top left corner of the **Power Graph** window.

# All in One & Giv-Gateway Configuration



**Step 3:** In the expanded view, you'll be able to view a detailed graph about your battery charge and discharge, battery percentage, as well as many other views.

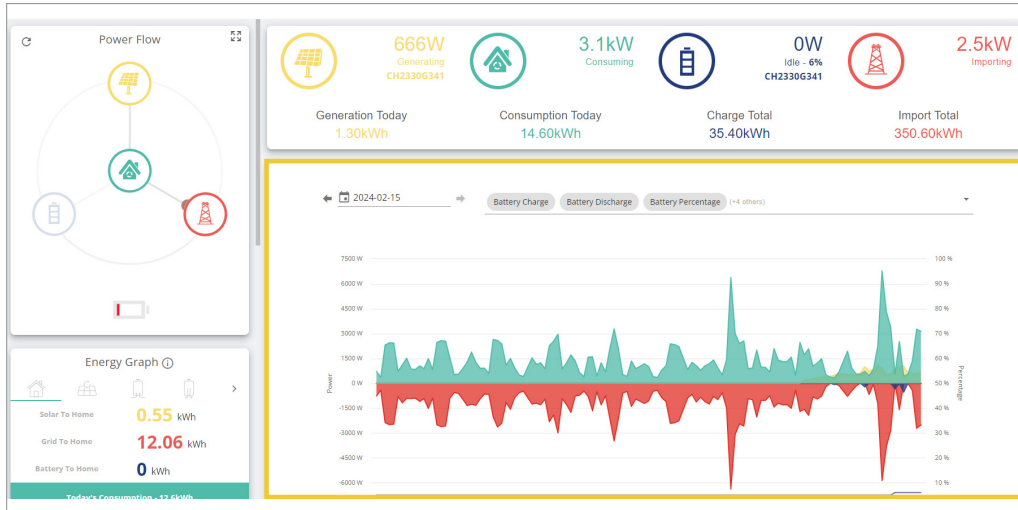

**Step 4:** To add/remove views, simply click the dropdown arrow and select from the dropdown list.

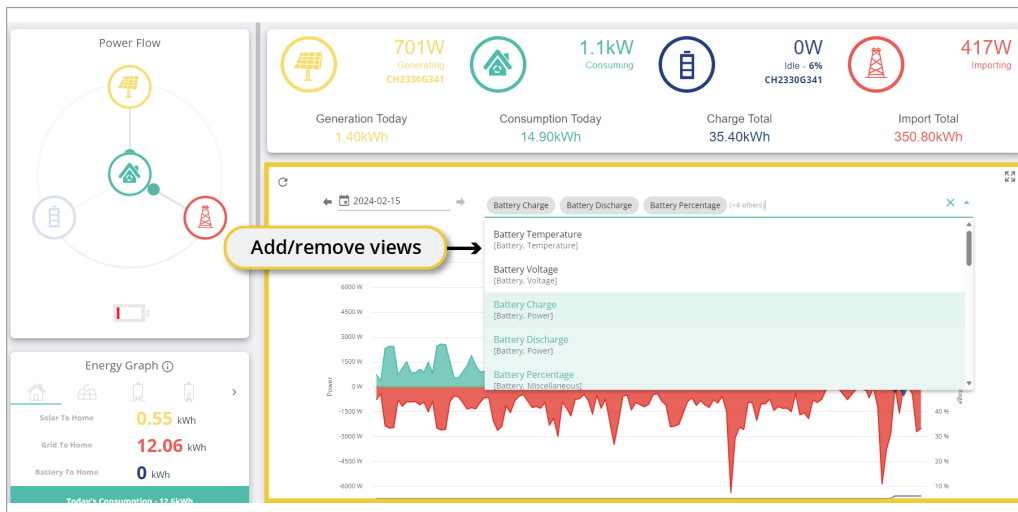

## Accessing data on the App

**Step 1:** Download the **GivEnergy App** from the **Google Play / App Store** on your device.

**Step 2:** Log in using your credentials.

**Step 3:** After logging in, you'll be shown the **App Dashboard**. This is a simplified version of the **GivEnergy Monitoring Portal**.

**Step 4:** The navigation menu displayed at the bottom of the screen allows you to cycle through your **Power** and **Energy Graph**.

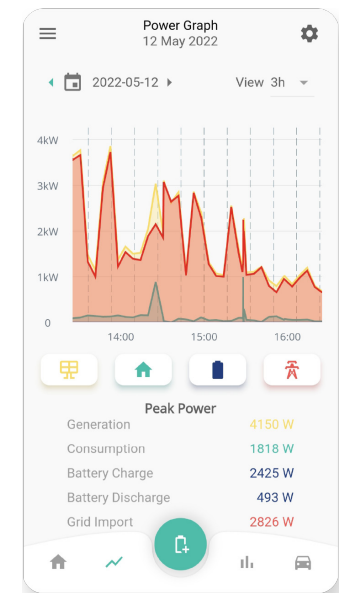

If data is not being displayed correctly on the GivEnergy Monitoring Portal or App, please contact the GivEnergy Service Desk on 01377 252 874 or email [support@givenergy.co.uk](mailto:support@givenergy.co.uk).

**Step 3:** On the **Commissioning Page**, select **'Create Commission'** at the top of the window.

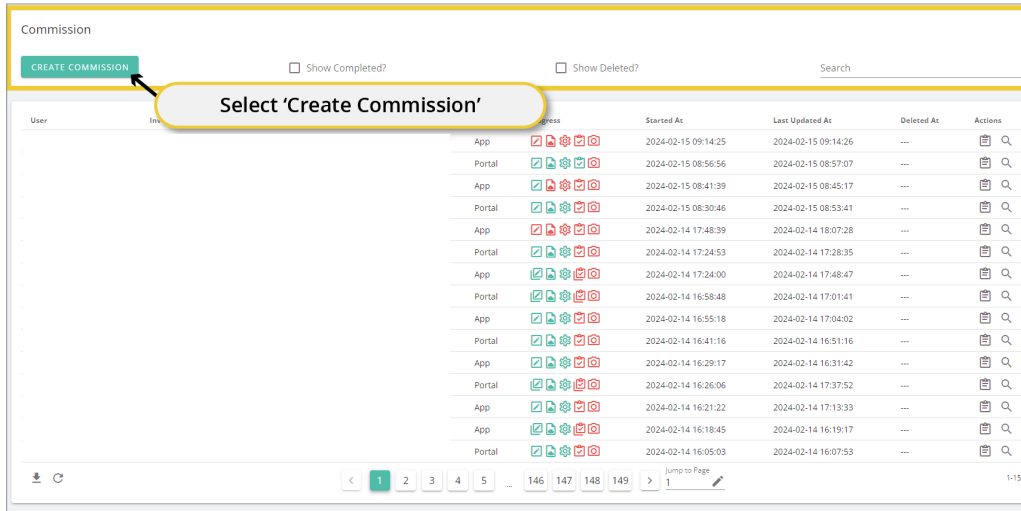

**Step 4:** You will now start the **Commissioning** process. Follow the instructions from Step 1 - 4. The region can be set in **Step 4** under **'Configure System'**.

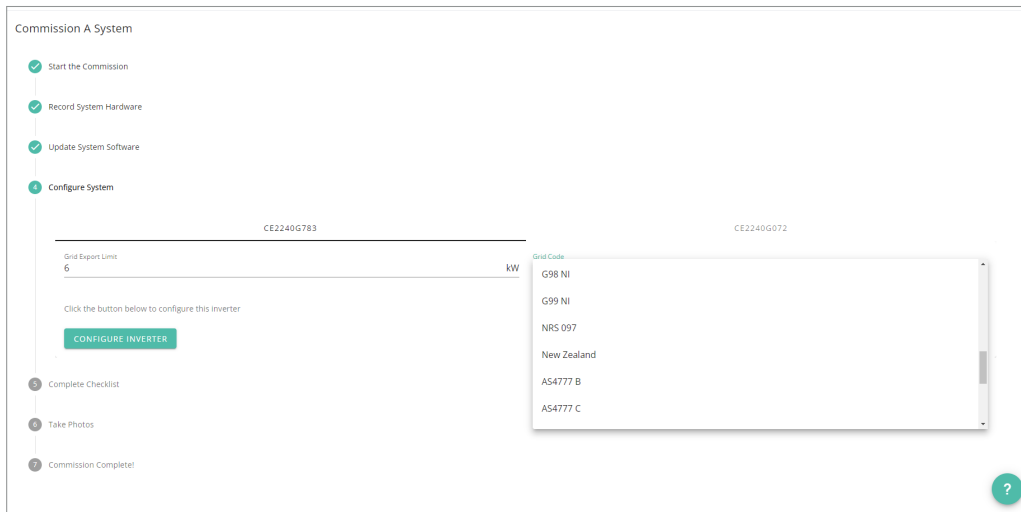

**Step 5:** Select the region from the dropdown list under **'Grid Code'**.

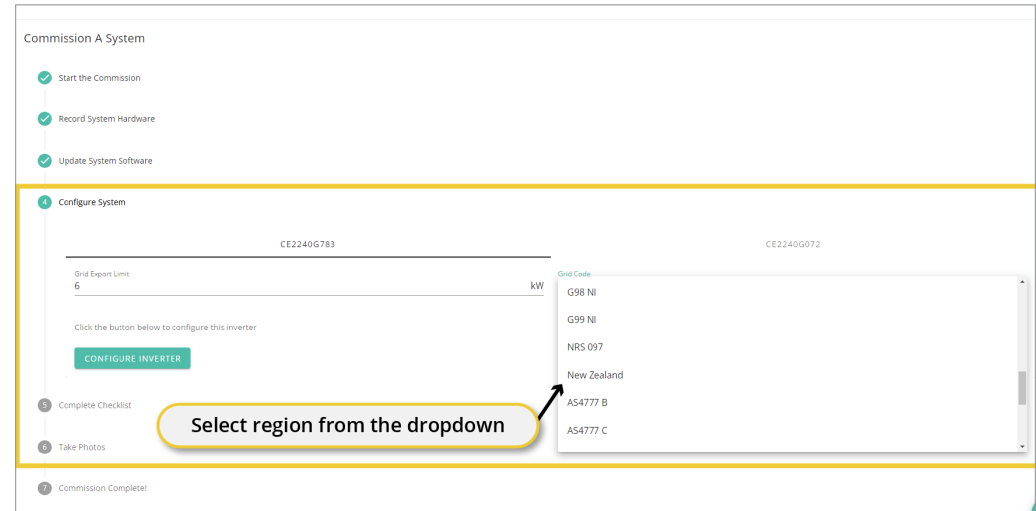

**Step 6:** Click **'Configure Inverter'** to confirm the region settings.

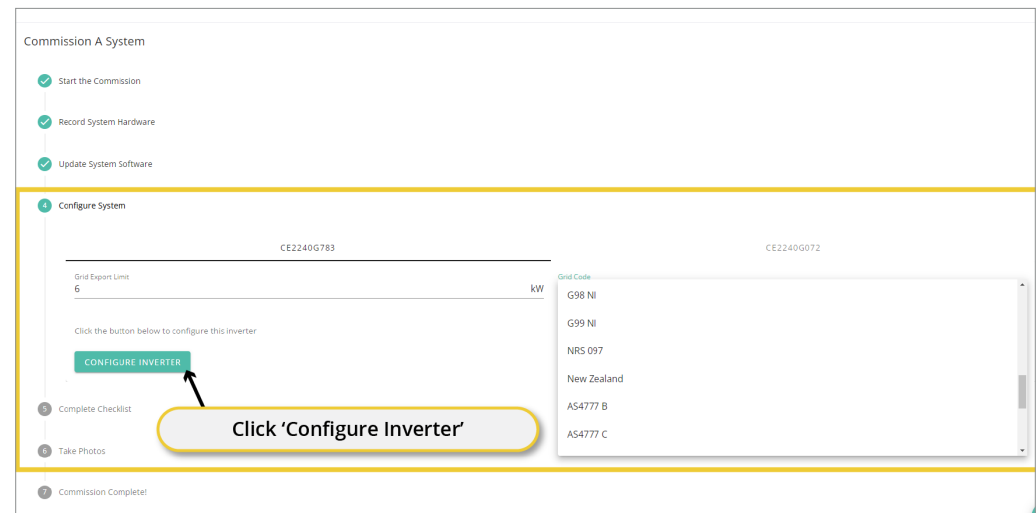

If the local grid operator requires other settings instead of the default please contact GivEnergy on **01377 252 874** or email [support@givenergy.co.uk](mailto:support@givenergy.co.uk) to change them remotely from GivEnergy's cloud server.

# VIEW INVERTER FIRMWARE AND SETTINGS

To view your inverter firmware:

**Step 1:** Log into the GivEnergy Monitoring Portal at [www.givenergy.cloud](http://www.givenergy.cloud).

**Step 2:** On your portal dashboard, hover over the 'My Inverter' card and select the expand icon.



**Step 3:** Click 'Software' on the All in One card. You can cycle through your installed products using the arrows on either side of the window.



# VIEW INVERTER FIRMWARE AND SETTINGS

**Step 4:** Your Inverter firmware version is displayed on this page. You can also update your firmware (if required) by pressing the 'Update Firmware' button. Click the arrow to cycle to your Giv-Gateway.

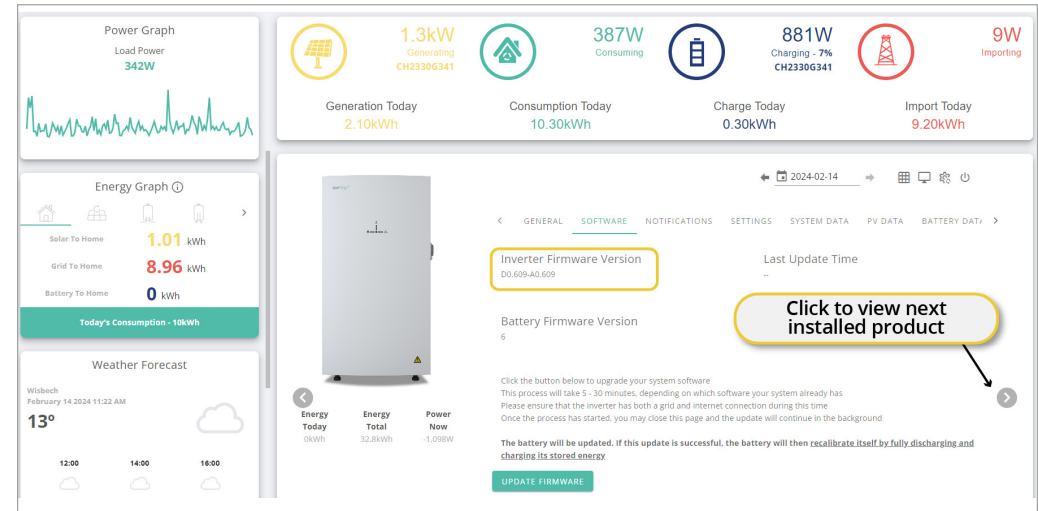

**Step 5:** Click 'Software' on the Giv-Gateway card.

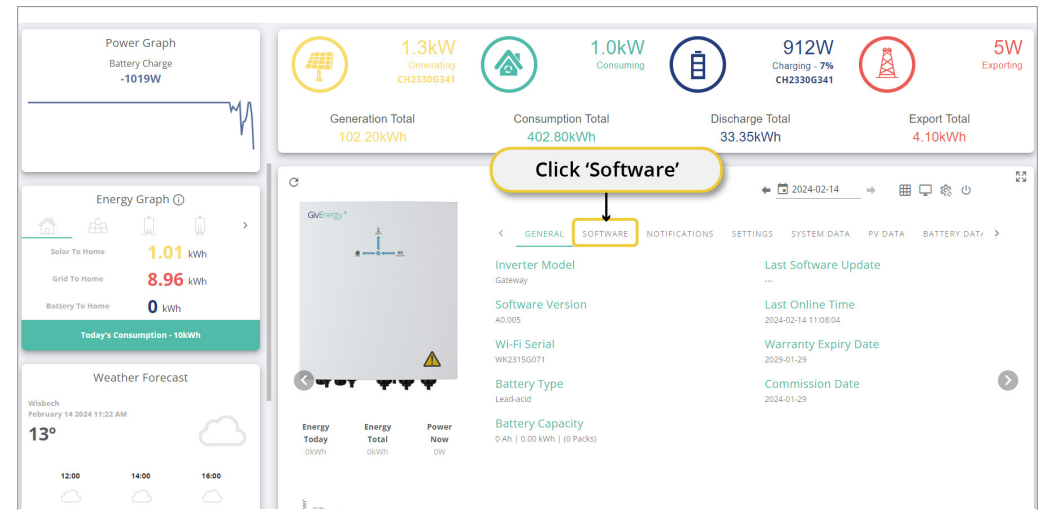

## VIEW INVERTER FIRMWARE AND SETTINGS

**Step 6:** Your Giv-Gateway firmware version is displayed on this page.

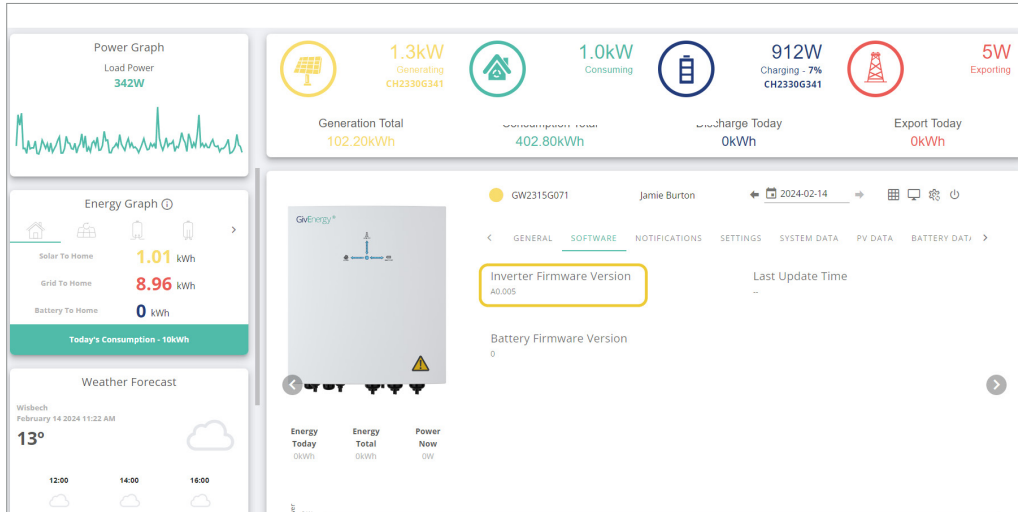

**Step 7:** Scroll down the page until you see the 'Control' section.

The screenshot shows the 'Control' section of the GivEnergy Monitoring Portal. It includes fields for 'System Time Year' (2024), 'System Time Month' (January), 'System Time Day' (29), 'System Time Hour' (16), 'System Time Minute' (2), and 'System Time Second' (47). There are also fields for 'Serial Number' (Inverter Serial Number Characters 1 & 2, 3 & 4, 5 & 6, 7 & 8, 9 & 10) and 'Software Version' (AD.005). A yellow callout box with an arrow points to the 'Control' section, containing the text: "Scroll down until you reach the 'Control' section".

## GENERATION CONTROL & EXPORT CONTROL SETTINGS

To adjust generation and export control settings:

**Step 1:** Log into the GivEnergy Monitoring Portal at [www.givenergy.cloud](http://www.givenergy.cloud).

**Step 2:** On your portal dashboard, hover over the 'My Inverter' card and select the expand icon.

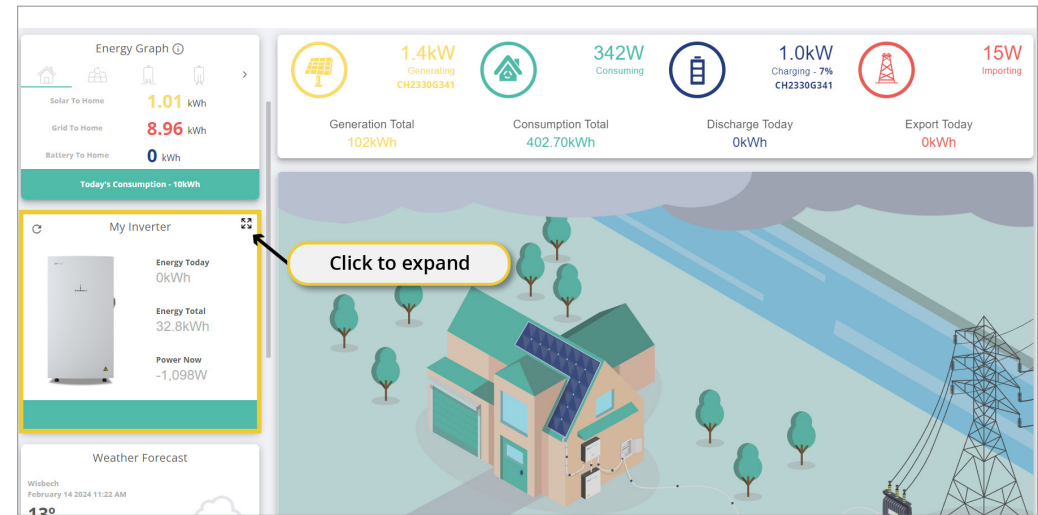

**Step 3:** In the 'My Inverter' screen, click the 'Remote Control' button found in the top right corner of the window.

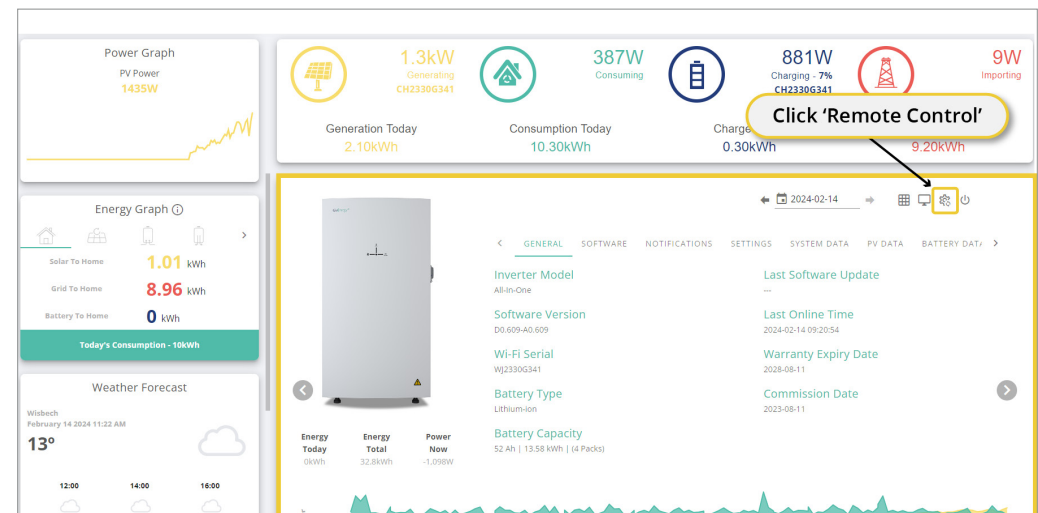

# GENERATION CONTROL & EXPORT CONTROL SETTINGS

**Step 4:** Click 'Inverter' at the top of the Remote Control page.

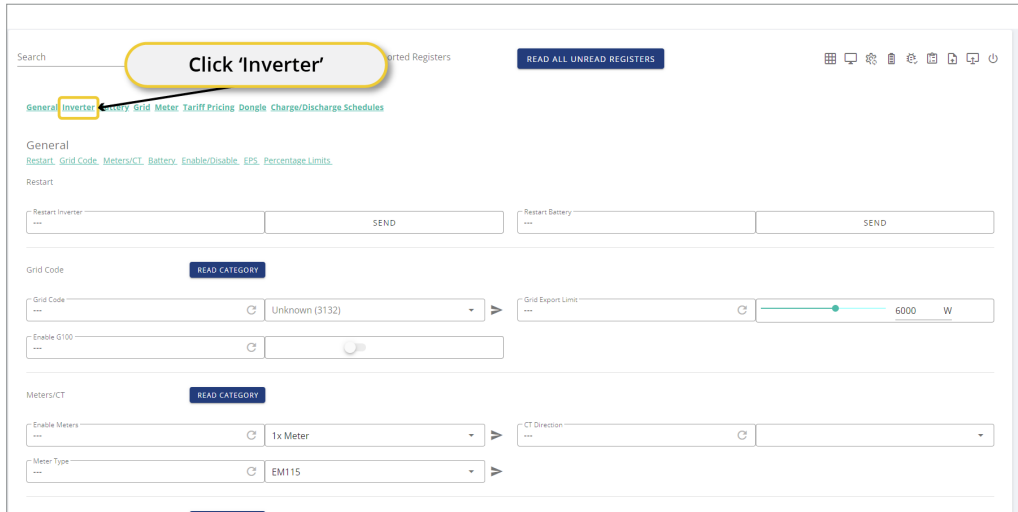

**Step 5:** Scroll down the page until you see the 'Control' section.

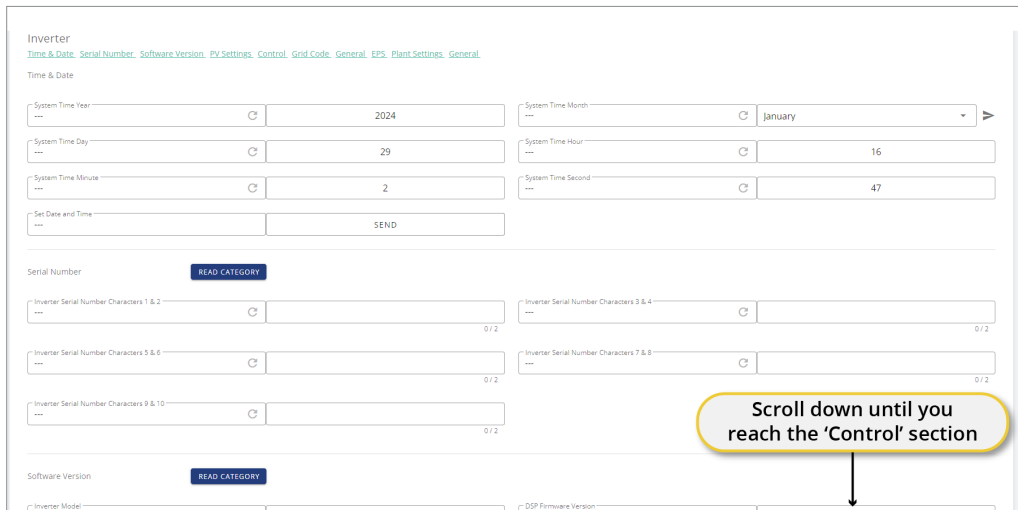

# GENERATION CONTROL & EXPORT CONTROL SETTINGS

**Step 6:** To adjust Generation Control, adjust the slider in the 'Inverter Max Output Active Power Percent' field between 0 and 100%. This is a combined hard and soft limit.

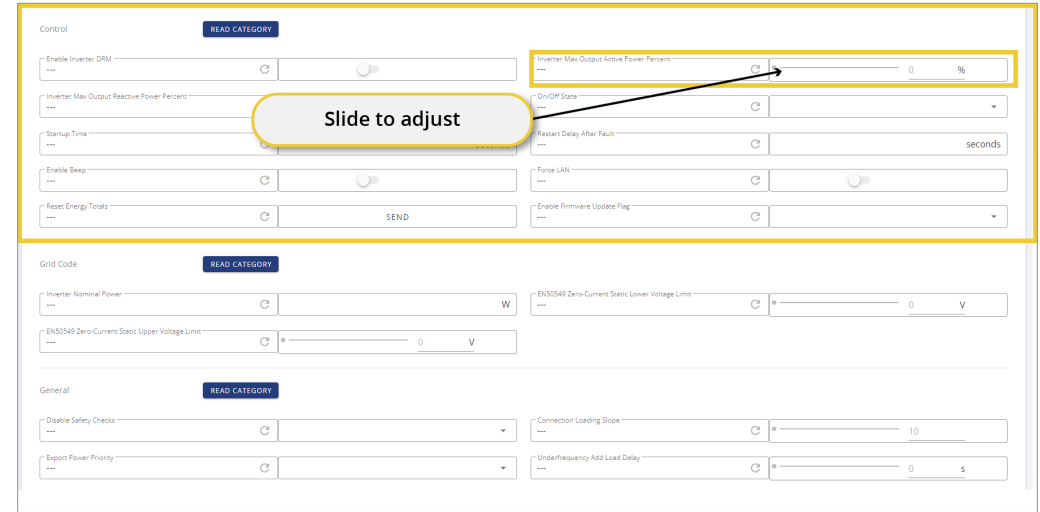

**Step 7:** To adjust the Export Control, scroll back to the top of the page and under 'Grid Code' in the 'General' section, toggle to enable G100 in the 'Enable G100' field.

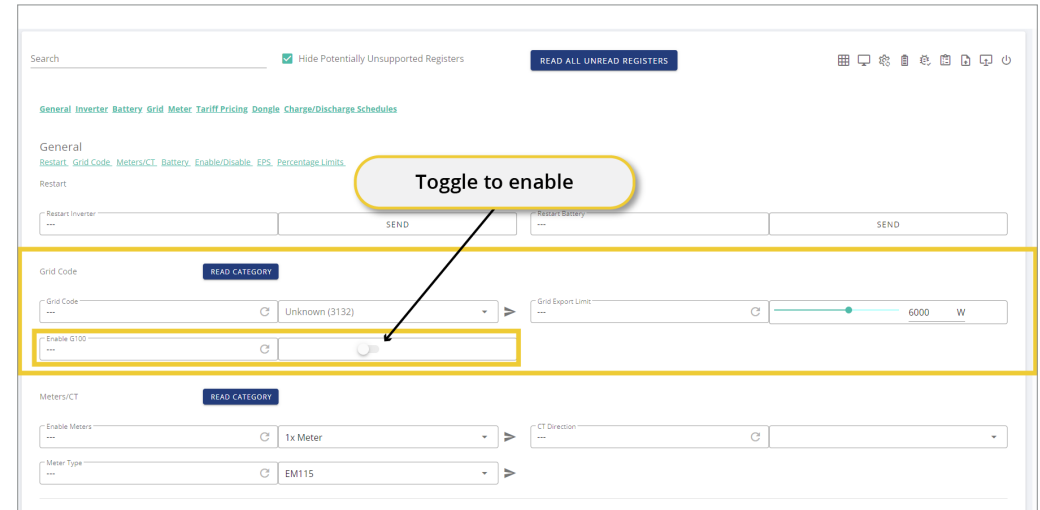

**Step 8:** Adjust the **Export Limit** by sliding the value in the 'Grid Export Limit' field. This is a combined hard and soft limit.

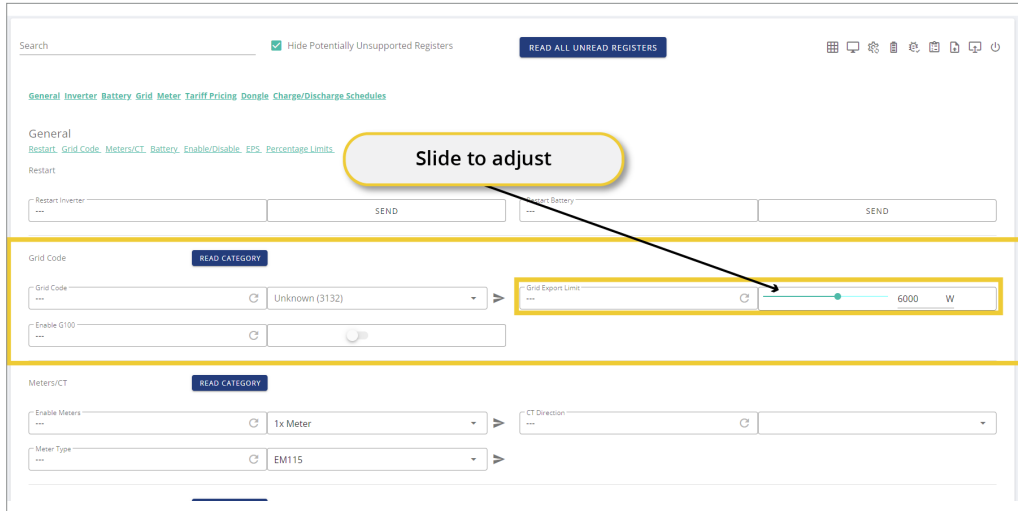

WE / WF / WO / WG / WH / WJ / WK serial number

**Step 1:** Accessing your WiFi settings



Accessing your WiFi settings.

Select the WiFi network that matches the dongle serial number.

Click Connect when it is visible (ensure **Connect automatically** is ticked)

**Step 2:** Logging in to your local inverter WiFi settings

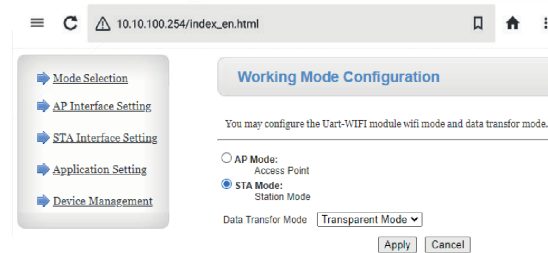

Open your **web browser** (preferably Google Chrome). Type **10.10.100.254** into the address bar.

When prompted enter:

**Username:** admin

**Password:** admin\*



**Step 3: Select Mode**

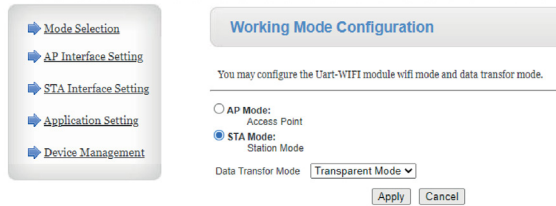

Select Mode Selection.

Select STA mode.

Click Apply.

**Step 4: Connecting to your WiFi**

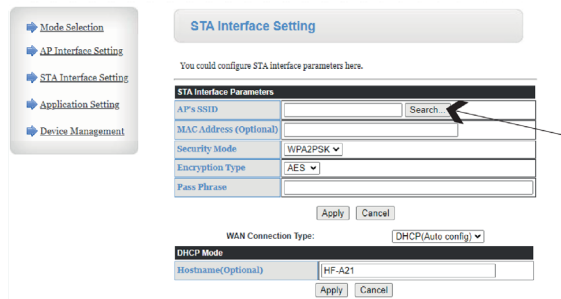

Select STA Interface Setting.

Click the Search button.

**Step 5: Selecting your WiFi network**

SSID	BSSID	RSSI	Channel	Encryption	Authentication	Network Type
<input checked="" type="radio"/> GivEnergy Lab	74:da:88:95:c7:de	37%	6	AES	WPA2PSK	Infrastructure
<input type="radio"/> DISPLAY_TABLETS	06:ec:da:3b:77:5d	26%	6	AES	WPA2PSK	Infrastructure
<input type="radio"/> WF2125G793	34:ea:e7:7f:e6:5c	89%	11	NONE	OPEN	Infrastructure
<input type="radio"/> HideSSID	76:ac:b9:97:33:e6	83%	11	AES	WPA2PSK	Infrastructure
<input type="radio"/> WE1812G001	f0:fe:6b:73:4b:98	20%	11	AES	WPA2PSK	Infrastructure
<input type="radio"/> WZ2108G038	98:d8:63:9b:29:b9	78%	11	NONE	OPEN	Infrastructure
<input type="radio"/> WF2026G304	98:d8:63:97:37:fc	100%	11	NONE	OPEN	Infrastructure

Apply Refresh

Select your WiFi network from the list.

Click Apply. Click Refresh if your network doesn't appear (see troubleshooting for more support).

RSSI (signal strength) should be at least 60% for a reliable signal.

A WiFi booster/extender may be required if signal strength is <60% (see diagram).

**Step 6: Inputting your WiFi password**

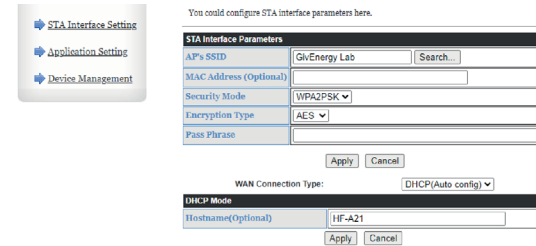

**Note:** If the desired network does not appear, you can manually enter it here.

Enter the customer's WiFi password.

Click Apply.

**Step 7: Setting your security modes**

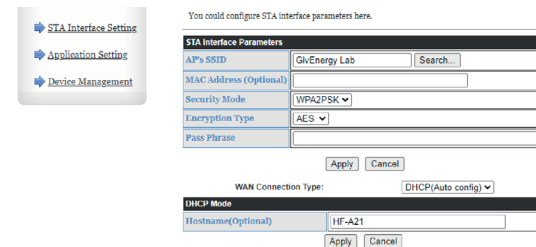

Select AP Interface Setting.

Select WPA2-PSK from the drop down menu in Security Mode.

Click Apply.

To hide the WiFi network name of the dongle when it is broadcasting you can tick the hide SSD box.

If you are having interference on a WiFi channel, or if it is causing issues with your home WiFi you can try changing the WiFi channel here.

If you wish to change the IP address of the dongle you can modify this here.

**Step 8:** Selecting your dongle password

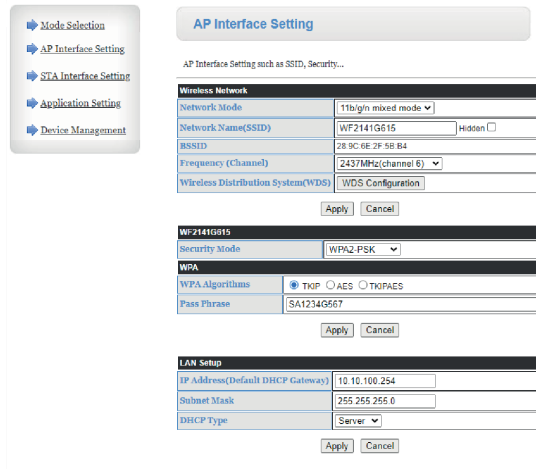

Choose a **password** (inverter serial no. is recommended).  
Click **Apply**.

**Step 9:** Restart dongle

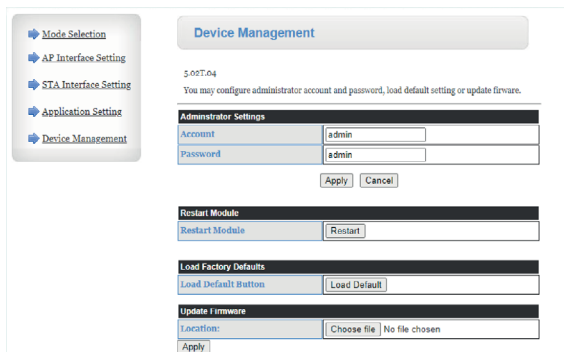

Select **Device Management**.  
Select **Restart**.

The screen will display Rebooting, this will stay on your screen indefinitely but the process only takes at maximum 10 minutes. If after 10 minutes your system is still not connected refresh your page and then please try the steps again, or refer to our **Troubleshooting** steps in our full guide at: [www.givenergy.co.uk/resource-hub/](http://www.givenergy.co.uk/resource-hub/)

**Commissioning Overview**

All systems must be commissioned to ensure correct battery and meter communications, as well as connection to the online portal.

**Note: Without commissioning, the system may not operate correctly.**

Check that all the wires are securely connected before the battery breaker and the AC isolator is switched on. You **MUST** set the parameters of the battery according to your battery system.

When commissioning the system, please use the **GivEnergy app** available from the **Google Play/App Store** and refer to our **GivEnergy Portal and App guide** found on our **Resource Hub** at [www.givenergy.co.uk](http://www.givenergy.co.uk).

When you start a commission, you will be prompted to input the grid code from a drop down list. Please confirm with your local grid operator on which Region to select.

**Accessing the Commissioning Portal/GivEnergy app**

Either sign into the online portal at <https://portal.givenergy.cloud>, or the GivEnergy app with your GivEnergy Engineer login. If you are a first time user, and you do not have an account or Engineer login, please consult your supplier to get this set up.

➤ To download a fully illustrated guide, please visit our **Resource Hub** at [www.givenergy.co.uk](http://www.givenergy.co.uk)

**Setting up the internet connection**

Sign into the **GivEnergy app** and follow the in-app instructions.

**End user account creation**

To set up GivEnergy account the end user will provide their email address to the installer/installation company. Upon successful commission of the equipment the end user will be emailed with a prompt to set up their account and gain access to the portal. Upon signing in to the portal for the first time they will go through a walk-through explaining how to navigate the portal and mobile app.

**Decommissioning the system**

To decommission the system please contact GivEnergy either by phone on **01377 252 874** or email at [support@givenergy.co.uk](mailto:support@givenergy.co.uk).

Please confirm with your local grid operator on which Region to select.

# All in One & Giv-Gateway Fundamentals

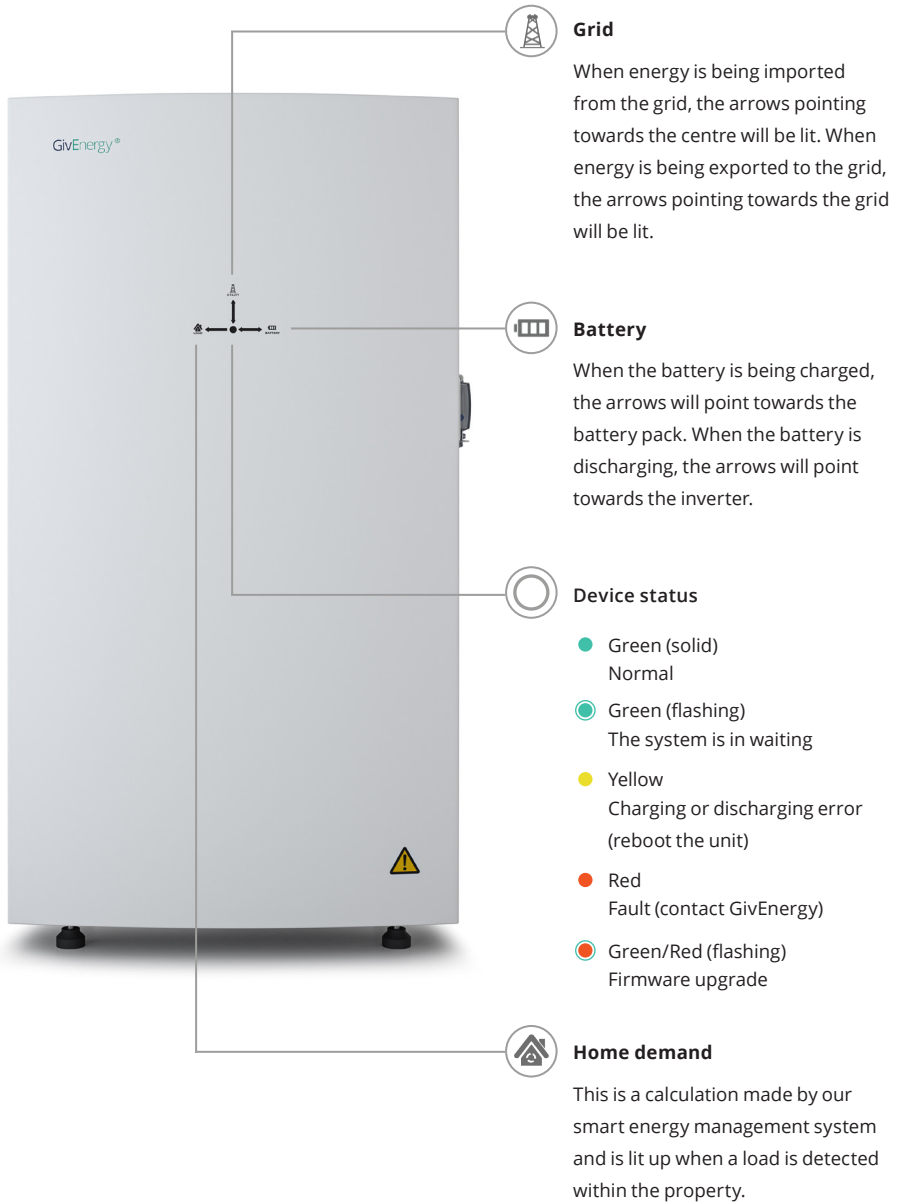

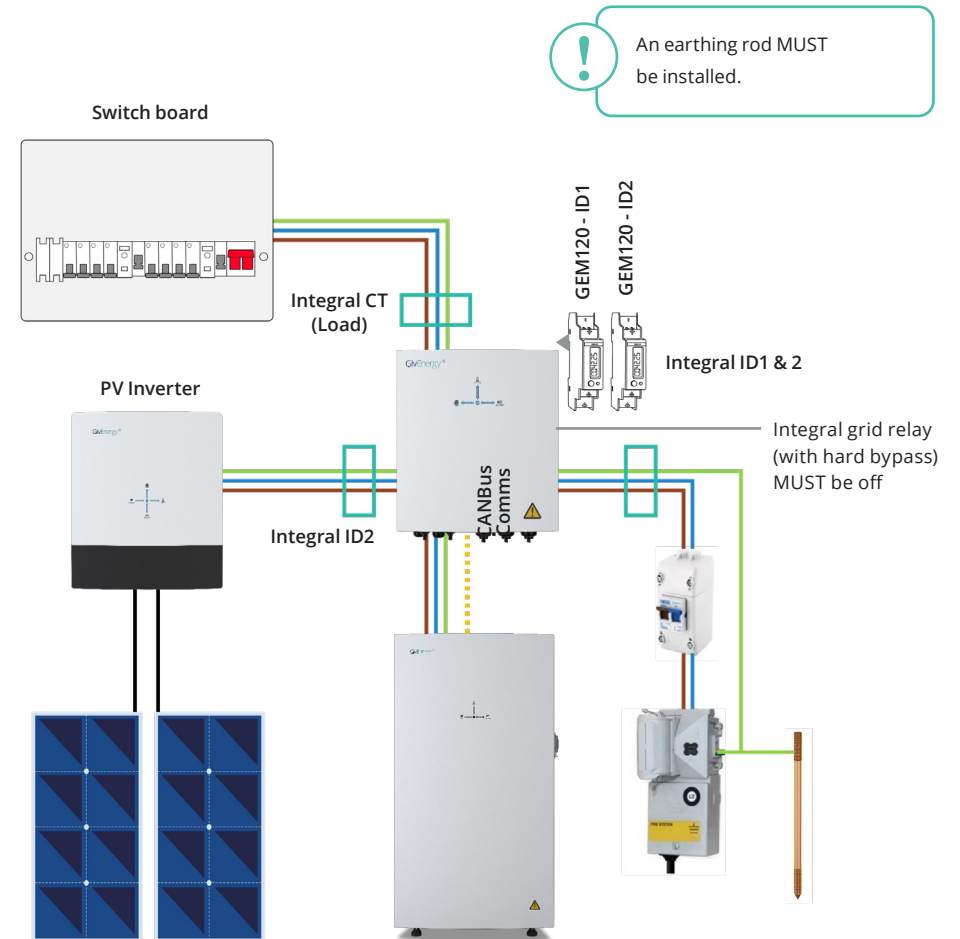
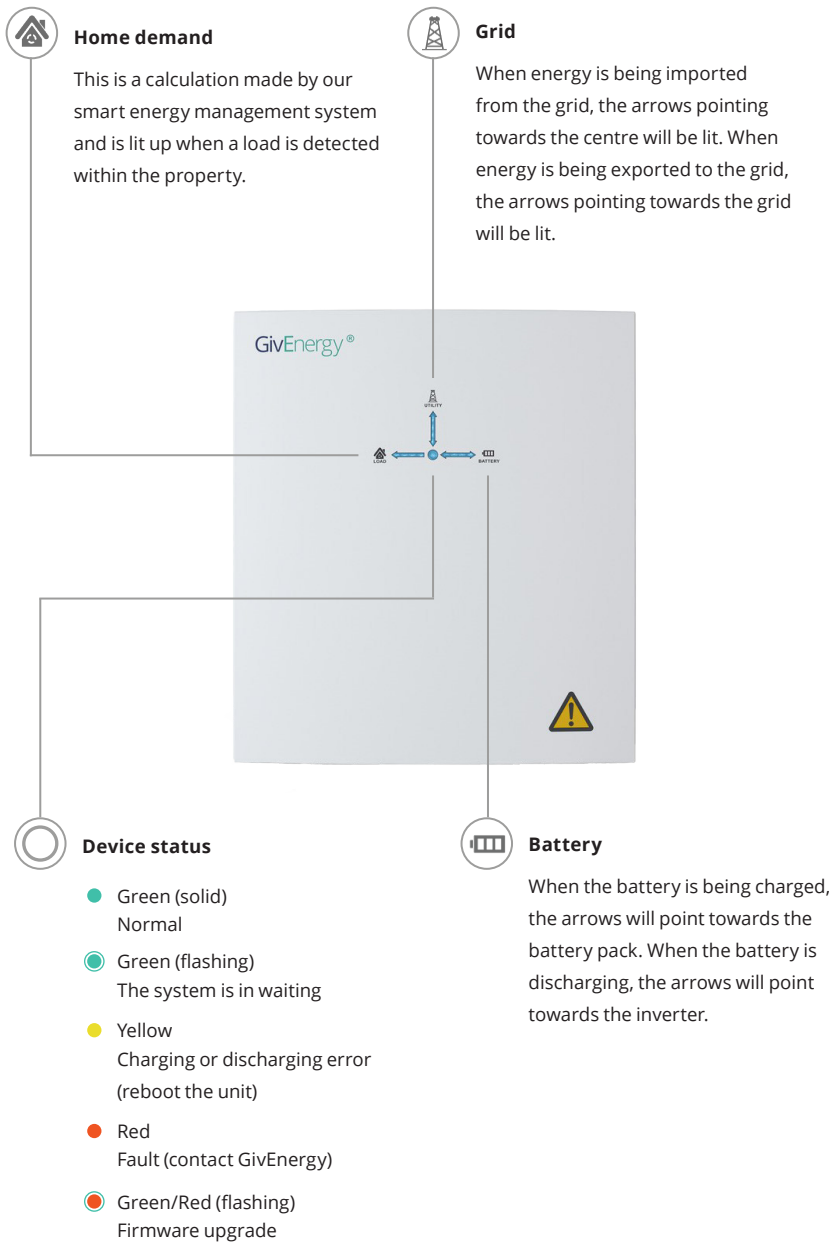

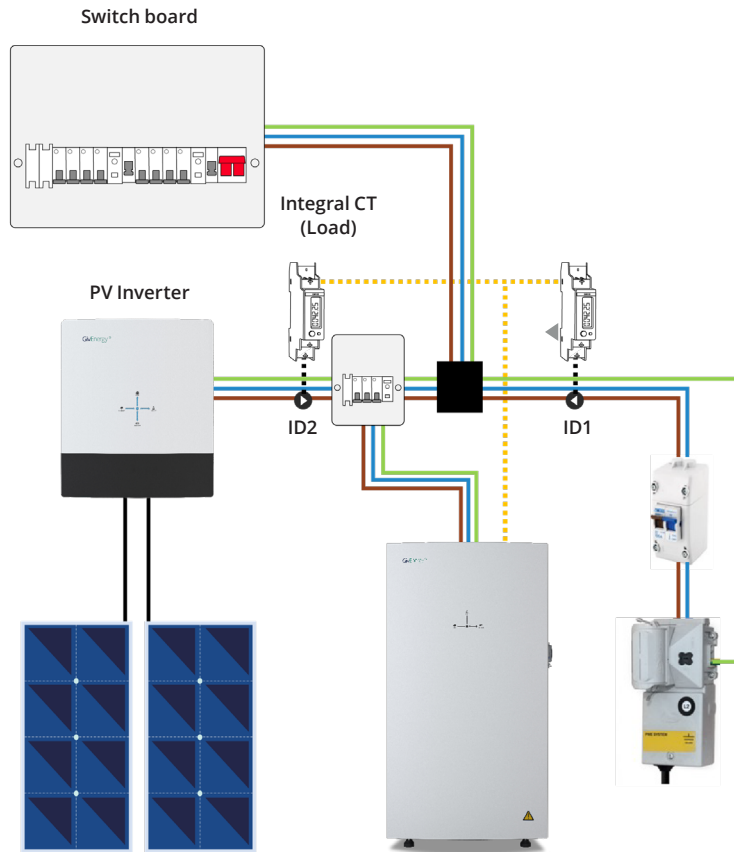

**Off Peak Charging**

This is prioritised to charge the battery during off peak times when energy is cheaper, greener, and cleaner. The battery will start to discharge outside of the off peak time when energy is more expensive.



**Solar Charging**

This is prioritised to charge the battery utilising excess solar generation, when energy is cheaper, greener, and cleaner. The battery will start to discharge outside of the peak generating hours when energy is more expensive.



**Back Up / Island Mode**

The system has the ability to be used in the event of a power cut. To utilise this the All in One must be connected to a Giv-Gateway. In the event of a power cut the Giv-Gateway will seamlessly switch over to battery to power the whole home.



**Off Grid Operation**

Remotely disconnect your home from the grid at the push of a button using the GivEnergy App or Online Monitoring Portal.

# MANUFACTURER WARRANTIES

The All in One and Giv-Gateway are covered by **12-year warranties**.

## Products Covered



**All in One 13.5**  
12 years

**All in One 3.6 13.5**  
12 years

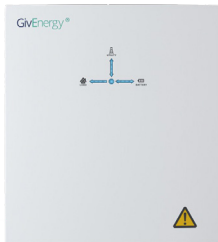

**Giv-Gateway**  
12 years

Warranty documents can be found on our resource hub at [www.givenergy.co.uk/resource-hub/](http://www.givenergy.co.uk/resource-hub/)

**Legal Disclaimer:** This document is the property of GivEnergy, reproduction is prohibited.



**Work with the best in the energy management business**

**GivEnergy HQ**

Osprey House, Brymbo Rd  
Newcastle-under-Lyme  
ST5 9HX

**[www.givenergy.co.uk](http://www.givenergy.co.uk)**

01377 252 874

