

## Powerwall 2 Transportation and Storage Guidelines



## Table of Contents

1. Purpose .....	2
2. Safety .....	2
3. Packaging.....	2
Packaging Specifications .....	2
Contents .....	3
4. Handling .....	3
5. Storage.....	4
6. Shipping .....	5
General Shipping Guidance .....	5
Shipping by Truck.....	5
Shipping by Air.....	5
Coolant .....	5
7. In Case of Damage .....	6
8. Repackaging.....	6
9. Revision Log.....	8

©2018 TESLA, INC. All rights reserved.

All information in this document is subject to copyright and other intellectual property rights of Tesla, Inc. and its licensors. This material may not be modified, reproduced or copied, in whole or in part, without the prior written permission of Tesla, Inc. and its licensors. Additional information is available upon request. The following are trademarks or registered trademarks of Tesla, Inc. in the United States and other countries:

TESLA	TESLA MOTORS	TESLA		POWERWALL
-------	--------------	-------	--	-----------

All other trademarks contained in this document are the property of their respective owners and their use herein does not imply sponsorship or endorsement of their products or services. The unauthorized use of any trademark displayed in this document or on the product is strictly prohibited.



## 1. Purpose

This document provides Tesla Certified Installers necessary details about packaging, storage, and shipping of Powerwall 2 units. For more information, contact Tesla.

## 2. Safety

Refer to the Tesla *Lithium-Ion Emergency Response Guide* (ERG) TS-0004027 for detailed hazard information specific to the lithium-ion battery in Tesla Powerwall 2. Section 9 of the ERG provides guidance and cites example regulations for shipment of dangerous goods. All logistics companies in the supply chain are responsible for knowing and following all applicable regulations pertaining to the storage, handling, and transportation of dangerous goods.

A printed copy of the ERG document is included in a shipping pouch on the outside of each Powerwall 2 box.

## 3. Packaging

### Packaging Specifications

Powerwall 2 is packaged in a box that is designed to hold the Powerwall unit and its parts. Powerwall 2 is shipped in stacks of up to 3 boxes strapped to a pallet.

Single Powerwall 2 box

Weight of single Powerwall 2 in box	145 kg (320 lbs)
Length	1320 mm (52 in)
Width	955 mm (37.5 in)
Height	305 mm (12 in)

Pallet with three Powerwall 2 boxes

Weight of three Powerwall 2 boxes and pallet	453 kg (998 lbs)
Length	1320 mm (52 in)
Width	955 mm (37.5 in)
Height	1045 mm (41 in)

Stack of two pallets with three Powerwall 2 boxes each

Weight of six Powerwall 2 boxes on two pallets	906 kg (1997 lbs)
Length	1320 mm (52 in)
Width	955 mm (37.5 in)
Height	2090 mm (82 in)



## Contents

Individual Powerwall 2 boxes should not be unpacked for storage or transportation. Each Powerwall 2 box contains all components needed for an installation:

- Documents in a pouch on the outside of the box
  - *Lithium-Ion Battery Emergency Response Guide*
- Powerwall unit
- Box containing mounting bracket
- Bag containing:
  - Printed Safety Instructions
  - Electrical connectors and wiring
  - Other tools and accessories

## 4. Handling



**Caution:** Keep Powerwall 2 flat on its back (front facing up) and in its packaging until installation.



**Caution:** Individual Powerwall 2 boxes should not be removed from their pallets until loading for final delivery.



**Caution:** Each Powerwall 2 is to be handled in its shipping box. Keep each unit in its box until it reaches its destination.



**Caution:** Ensure the packaging is not punctured. Protect packaging from weather and extreme temperatures.



**Caution:** Powerwall 2 is heavy. Wear appropriate personal protective equipment (such as gloves and protective footwear) when handling the unit.



**Caution:** Do not try to pick up a Powerwall 2 box directly with a forklift, as the forks may puncture the box.

To remove a single Powerwall 2 box from a pallet:

- Position a forklift or lift table beside the pallet so that it is level and about 5 cm (two inches) below the edge of the box.
- Cut the straps holding the box to the pallet.
- Slide the box from the pallet onto the forklift or lift table.

Follow these rules when handling pallets of Powerwall 2 boxes in the warehouse:

- Do not stack or transport other items on top of Powerwall 2 boxes.
- Stack a maximum of two pallets with 3 boxes each (total of 6 boxes)
- Move a maximum of two pallets (total of 6 boxes) at a time. When moving two stacked pallets, they must be strapped together.

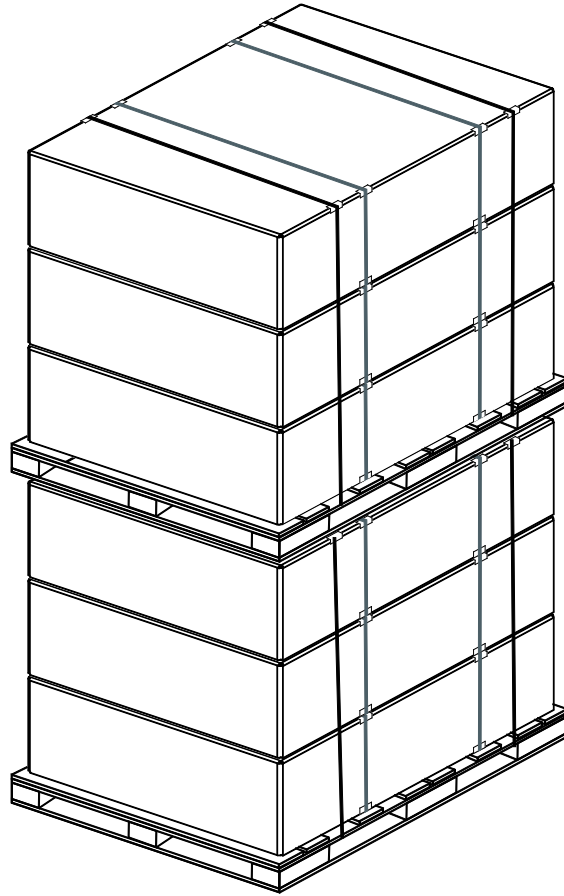

## 5. Storage

References to storage in this section refer to on-the-shelf conditions with batteries disconnected from the grid.

The maximum acceptable storage duration (without measures to maintain function) is 12 months if the unit has an initial SOE of 25% and humidity is < 95% non-condensing.

Storage Duration	Allowable Temperature Range
Up to 1 week	-30 °C to 60 °C (-22 °F to 140 °F)
Up to 1 month	-30 °C to 45 °C (-22 °F to 113 °F)
Between 1 and 12 months	-20 °C to 30 °C (-4 °F to 86 °F)



## 6. Shipping

### General Shipping Guidance

Powerwall 2 is a Class 9 dangerous good when transported in commerce (highway, rail, air, or vessel).

The liability of the product is transferred when the ownership is transferred. Therefore, each distributor is responsible for shipping the product in accordance with the applicable transportation regulations.

The UN Number and Proper Shipping Name for Powerwall 2 are as follows:

- UN 3480, Lithium Ion Batteries

The UN Number and Proper Shipping Name are the same by any mode of transport, across the world.

Each distributor is responsible for ensuring that staff who will transport, or offer for transport, Powerwall 2 are trained in accordance with the applicable transportation regulations. This includes staff who prepare the dangerous goods shipping papers and apply marks and labels to the package.

### Shipping by Truck

When shipping Class 9 dangerous goods by truck, guidelines can vary by region:

- **Within the United States, Australia, and New Zealand:** Trucks are exempt from placards and drivers are not required to have hazmat endorsement / licensing.
- **Within Europe:** Trucks carrying less than 300 kg are exempt from placards, and drivers are not required to have hazmat endorsement / licensing. Trucks carrying more than 300 kg are required to use placards and have hazmat endorsement / licensing.
- **Shipping in all other regions:** Please refer to local regulations.

In all regions, regardless of shipment weight, the driver must be made aware that the shipment contains Class 9 dangerous goods, which requires dangerous goods shipping paperwork. The paperwork can be in the form of a Bill of Lading (BOL), Job Sheet, or Delivery Order.

In addition to the guidance above, be sure to conform to all applicable national, state/provincial, and local regulations regarding storage and transport.

### Shipping by Air

If a Powerwall 2 will be transported by aircraft, the distributor will be required to obtain an authorization from the Competent Authority in the country in which the shipment will originate before they can offer the equipment for air transport.

### Coolant

The coolant used in the Tesla Powerwall 2 is not a regulated substance (not dangerous goods). The coolant MSDS can be provided upon request.



## 7. In Case of Damage

If a Powerwall 2 box appears to be damaged, address high voltage and other safety risks before handling the box or its contents.

For technical support or information on returning damaged units, contact [powerwallsupport@tesla.com](mailto:powerwallsupport@tesla.com).

If further support is needed, contact Tesla Support for your region. Support phone numbers and email addresses for each region are available at <https://www.tesla.com/support/powerwall>.

**NOTE:** For any shipment other than a new unit straight from Tesla's Gigafactory, check with the Tesla partner who initiated the transport request to ensure that they have contacted Tesla and verified the unit is at a state of charge (SOC) that is safe to ship.

 **Warning:** If Powerwall requires service or is damaged and cannot be serviced or repaired onsite, it must be returned to Tesla. Contact Tesla Support for instructions on obtaining a Return Merchandise Authorization (RMA) and any special handling or packaging that may be required, as well as any restrictions on transportation that may apply. For more information, refer to the [Powerwall 2 Return Process for Certified Installers](#).

## 8. Repackaging

If the original packaging has been damaged, you can repackage the unit before shipment.

 **Warning:** If the Powerwall shows signs of damage, do not repackage the unit in a new Powerwall box. Contact Tesla for instructions on packaging and returning a damaged Powerwall.

 **Caution:** Powerwall is heavy. Wear appropriate personal protective equipment (such as gloves and protective footwear) when handling the unit. Only a sufficient number of trained movers should lift Powerwall. Use of lift equipment is recommended.

### *Open the Old Box*

1. Lay the old box flat on its back.
2. Cut the packing straps.
3. Remove the old box lid.
4. Remove the box containing the Powerwall mounting bracket.
5. Remove the bag containing the Powerwall accessories.
6. Remove the top box panel to reveal the Powerwall 2 unit.

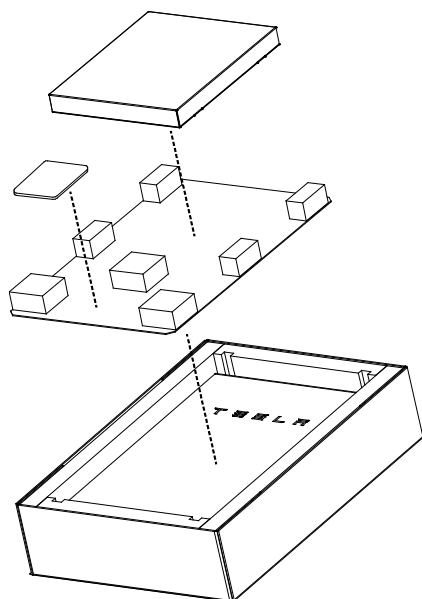

#### *Prepare the New Box*

1. Lay the new box flat on its back near the old box.
2. Remove the new box lid and set it aside.
3. Remove the new top panel and set it aside.

#### *Transfer the Powerwall 2 to the New Box*

1. Carefully remove the Powerwall 2 unit from the old box by grasping it from the top, tilting it up until it can be grasped near the bottom, and lifted carefully.
2. Place the Powerwall 2 unit in the new box by setting the bottom in place and tilting it down until the top rests in place.

#### *Pack the New Box*

1. Place the new top panel in the box on top of the Powerwall 2 unit, with the space for the mounting bracket box toward the top of the unit.
2. Transfer the box containing the mounting bracket to the new Powerwall 2 box.
3. Transfer the bag containing the accessories to the new box and tape it into place.
4. Place the new box lid onto the new box, in the same orientation as the old lid.
5. Apply packing straps to the box as shown below, using corner protectors on each edge.
6. If a new copy is not already present, transfer the *Lithium-Ion Battery Emergency Response Guide* from the pouch on the side of the old box to a sealed plastic pouch on the side of the new box lid. This guide must ship with Powerwall 2.

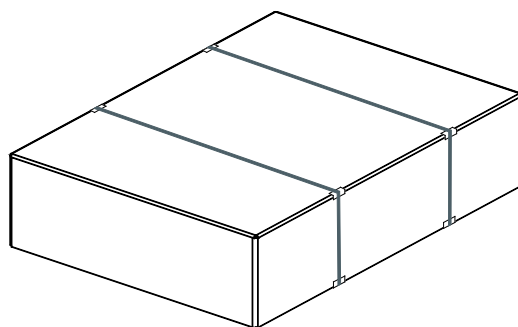





---

## 9. Revision Log

Revision	Date	Description
1.0	2016-12-20	Initial Release
1.1	2017-01-20	<ul style="list-style-type: none"><li>• Updated product weights</li><li>• Updated shipping guidance</li></ul>
1.2	2017-08-18	<ul style="list-style-type: none"><li>• Corrected UN product classification to UN3480</li><li>• Added mention of lift table</li></ul>
1.3	2018-08-08	<ul style="list-style-type: none"><li>• Added mention of RMA and link to “Powerwall 2 Return Process for Certified Installers” document</li></ul>