

ESDEC

INNOVATIVE MOUNTING SYSTEMS

CLICKFIT

EVO

MANUAL

MOUNTING SYSTEMS FOR SLOPING ROOFS WITH ROOF TILES

EN

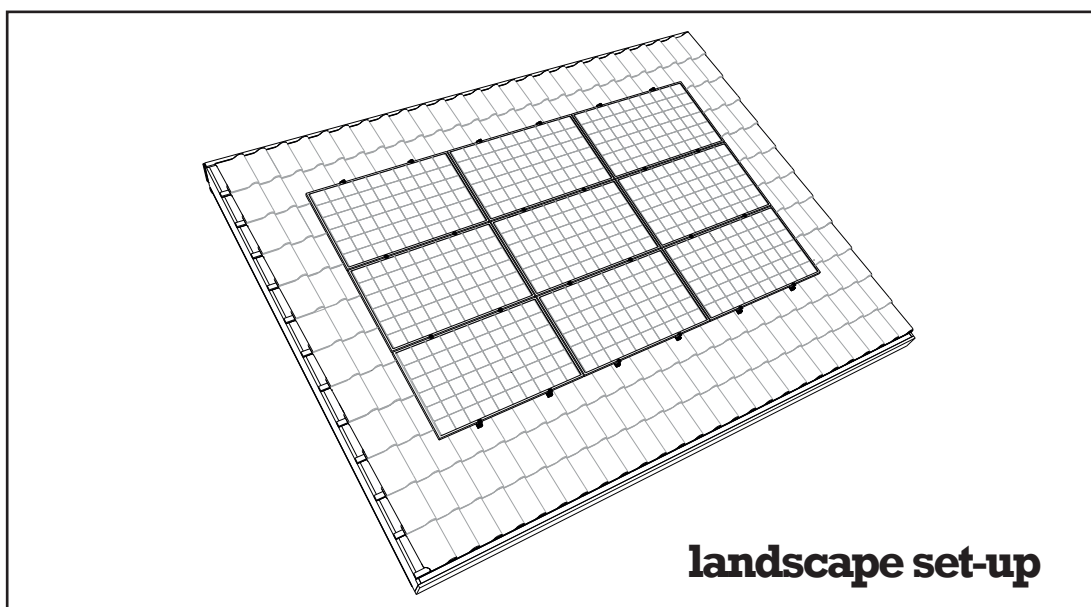
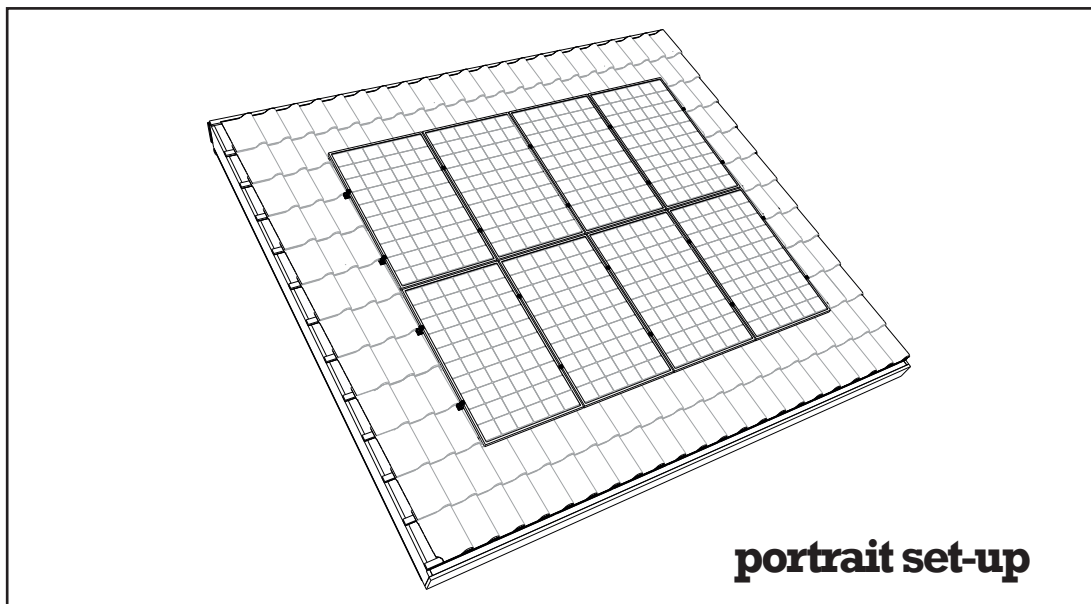

ClickFit Evo mounting system for sloping roofs with roof tiles for solar panels

Rev. 11.05.22

© ESDEC BV 2022

ESDEC

Londenstraat 16
7418 EE Deventer
The Netherlands

T +31 850 702 000
info@esdec.com
www.esdec.com

IBAN NL64 INGB 0658539531
BIC INGBNL2A
VAT NL813998955B01

CLICKFIT

FLATFIX

www.esdec.com

All our transactions and sales apply our Terms and Conditions which are filed with the Chamber of Commerce (08127728). These can be downloaded at www.esdec.com

CONTENTS

	page
1. Introduction	1
2. General installation conditions	1
3. Product description	3
4. Parts overview	3
4.1 Exploded-view mounting system in portrait set-up	3
4.2 Exploded-view mounting system in landscape set-up	4
4.3 Universal roof hook for portrait or landscape set-up	4
4.4 Parts list	5
5. Installation preparation	5
5.1 Checking tools and accessories	5
5.2 Clean the roof	6
5.3 Determining and measuring the position of the solar panels	7
6. Installation of mounting system in the portrait set-up	8
6.1 Pre-mounting of the mounting rail connector	8
6.2 Fastening universal roof hooks	9
6.3 Fastening the mounting rail	10
6.4 Installing mounting rail cable clip optimizer ready and optimizer (option)	11
6.5 Mounting 1st solar panel on the rails	12
6.6 Mounting other solar panels on the rails	13
6.7 Completing the mounting of the 1st row of solar panels	14
6.8 Completion of mounting/several rows below each other	15
7. Installation of mounting system in landscape set-up	16
7.1 Pre-installation of the mounting rail connector	16
7.2 Fastening of universal roof hooks	17
7.3 Fastening the mounting rail	18
7.4 Installing the mounting rail cable clip optimizer ready and optimizer (option)	19
7.5 Mounting 1st solar panel on the mounting rails	20
7.6 Mounting other solar panels on the rails	21
7.7 Completing the mounting of the 1st row of solar panels	22
7.8 Completion of installation / several rows alongside each other	23
8. Appendix	24
8.1 Specifications for installation	24
8.2 Tightening moments	25

PLEASE SAVE THIS INSTALLATION MANUAL CAREFULLY FOR FUTURE USE!

We recommend that you contact your supplier for the period and conditions relating to guarantees. We also refer you to our General Terms and Conditions of Sale and Supply, which are available on request.

The manufacturer rejects all liability for damage or injury caused by failure to meticulously comply with this installation manual and failure to apply normal levels of caution during the transportation, mounting and use of the ClickFit Evo mounting system.

As a consequence of ongoing efforts to implement improvements it can occur that details of the product are different to those described in this manual. For these reasons, the instructions given serve only as a guideline for the installation of the product specified in this manual.

This manual was created with great care, but the manufacturer cannot accept responsibility for any errors in this manual, or their consequences.

Furthermore, all rights are reserved and nothing from this manual may be multiplied in any manner whatsoever.

1. Introduction

This manual describes the installation of the ClickFit Evo mounting system for sloping roofs with roof tiles (for solar panels in portrait and landscape set-ups).

Read the manual carefully, so that you are aware of its entire contents. Follow the instructions in the manual meticulously. Always execute the actions in the correct sequence.

Store the manual in a safe and dry place. If you lose the manual there is an option to request a new copy from Esdec B.V.

2. General installation conditions

General

Failure to comply with the regulations specified in this document can result in the lapsing of all guarantee and product liability claims. The information, comments and recommendations in this document are binding and must be checked for completeness and current applicability. Esdec BV reserves the right to change this document without further prior announcement.

Stability and condition of the roof

The roof must be in good condition and sufficiently strong to bear the weight of the solar panels, including the additional materials, and wind and snow load. Check the stability of the roof and change the roof/construction where necessary. If there is any doubt, use the services of a construction company. Ensure that the load reserve of the roof is not exceeded either locally or in its entirety.

Safety warnings

- The mounting of the ClickFit Evo mounting system must be executed by qualified technical personnel (a minimum of 2 professionally qualified people) as standard.
- The addition or omission of components can have a detrimental effect on the operation and is strongly discouraged!
- For the placement of the solar panels the roof must be clean, dry, level and free of algae etc.
- Avoid mounting in high winds and if the roof surface is smooth and wet.
- Always wear a safety harness and use safety nets and edge protection if necessary when working on a sloping roof.
- Slide roof tiles upwards so that recesses are created in which you can place your feet. Attention! Never stand in the gutter.
- Wear shoes with reinforced toecaps and strong anti-slip soles.
- Always wear the correct protective clothing when executing the work.
- Always use a lifting assistance/hoisting installation when moving the material (solar panels, etc.).
- Always place a ladder on a strong, stable base.
- Always place the ladder at an angle of approximately 75° and allow it to extend approximately 1 metre above the edge of the roof.
- If possible, secure the top of the ladder with a rope or tensioning strap.
- Preferably, work in accordance with the “veilig werken op daken” (working safely on roofs) manual.

Application range ClickFit Evo

- The maximum allowable wind load etc can be determined by the ClickFit EVO calculator in compliance with MIS 3002. The ClickFit EVO calculator can be found on our website www.esdec.com or can be requested through customer support.
- Solar panels of all brands and models with a frame height between 30 and 50 mm with a maximum size of 2.6 m² per solar panel. Check whether the chosen solar panel can withstand the forces, in the documentation of the supplier of the solar panels.
- Clamping range adjustable hook (tile lath thickness and tile thickness): 32 - 65mm
- Maximum roof height: dependent on Eurocode guidelines and national additions. Use the calculator to calculate the possibilities for your project.
- Type roof covering: Sloping roof with roof tiles.
- Roof pitch: Between 10 - 60 degrees. **Note:** with a roof pitch lower than 20 degrees, check the specifications of the roof tile supplier. With a roof pitch of less than 20 degrees it is often necessary to take additional water-retaining measures, such as applying water-retaining foil under the roof tiles or grinding the roof tile at the hook.
- Use the calculator to ensure you select the right mounting system for the terrain category, snow load and wind zone applicable to your project.

Edge zone

The distance from the solar panels to the ridge and gutter must be a minimum of 30 cm, in connection with the wind load.

The distance from the solar panels to the side of the roof must be a minimum of 30 cm. Solar panels may not, either partially or completely, be mounted in this zone.

Standards, instructions and regulations

During the installation of the mounting system, it is important to adhere to the installation manual and the accompanying standards to prevent accidents. Pay special attention to (local) standards, regulations and legislation (among others):

- The Building Regulations 2010 (latest version)
- Health and Safety at Work etc Act 1974
- Health and Safety in Roof work - HSE
- Eurocodes 0 (EN 1990 - Structural Design)
- Eurocodes 1 (EN 1991 - (Influences on structures)
- HD-IEC 60363 series - Electrical installations for low voltage
- EN-IEC 62305-2 - Protection lightning - Risk Management
- MIS 3002 – The solar PV standard
- MCS012 - Product Certification Scheme Requirements: Pitched Roof Installation Kits



Removal and disassembly

Dispose of the product in compliance with local laws and regulations.

Warranty

Warranty according to the terms and conditions of Esdec BV. These can be found on the website www.esdec.com.

Maintenance

The ClickFit EVO system is designed to be virtually maintenance-free. A few points need to be checked to ensure structural integrity and the function of the system.

The following points need to be checked on a yearly basis and after each storm with wind speeds >9Bft.:

- The reliability of all bolt, nuts, screw and clamp connections.

o Action: Tighten all bolts, nuts, screws and clamps where necessary according to the installation manual and report it to Esdec BV including photographs.

- Overall visual control of ClickFit EVO system (corrosion of components, etc).

o Action: Report it to Esdec BV including photographs.

Liability

The manufacturer accepts no liability for damage or injury caused by not (strictly) adhering to the safety prescription and instructions contained in this manual, or by carelessness during installation of the product specified in this document and the eventual related accessories.

- Printing errors reserved

3. Product description

The ClickFit Evo mounting system consists of the patented adjustable universal roof hooks, mounting rails and the installation materials required for the mounting of solar panels on tiled roofs in a portrait or landscape set-up. The universal roof hook is fitted with a rotatable click bracket, which enable both horizontal and vertical mounting rails to be clicked securely onto the roof hook. The ClickFit Evo mounting system for tiled roofs can be used on all tiled roofs, regardless of the type of tile.

Roof fastening

The universal roof hooks are fastened to the tile laths. The fact that the universal roof hooks are not fastened to the roof trusses or joists means that you are free to choose the position of the solar panels on the roof. Height differences in the roof are easy to fill out with the aid of the adjustable, universal roof hook.

Fastening the mounting rail

The mounting rail is fastened to the Universal roof hooks with a click connector. This does not require any further materials or tools.

Fastening the panels

The solar panels are fastened to the mounting rails with the aid of universal module clamps.

4. Components overview

4.1 Exploded-view mounting system in portrait set-up

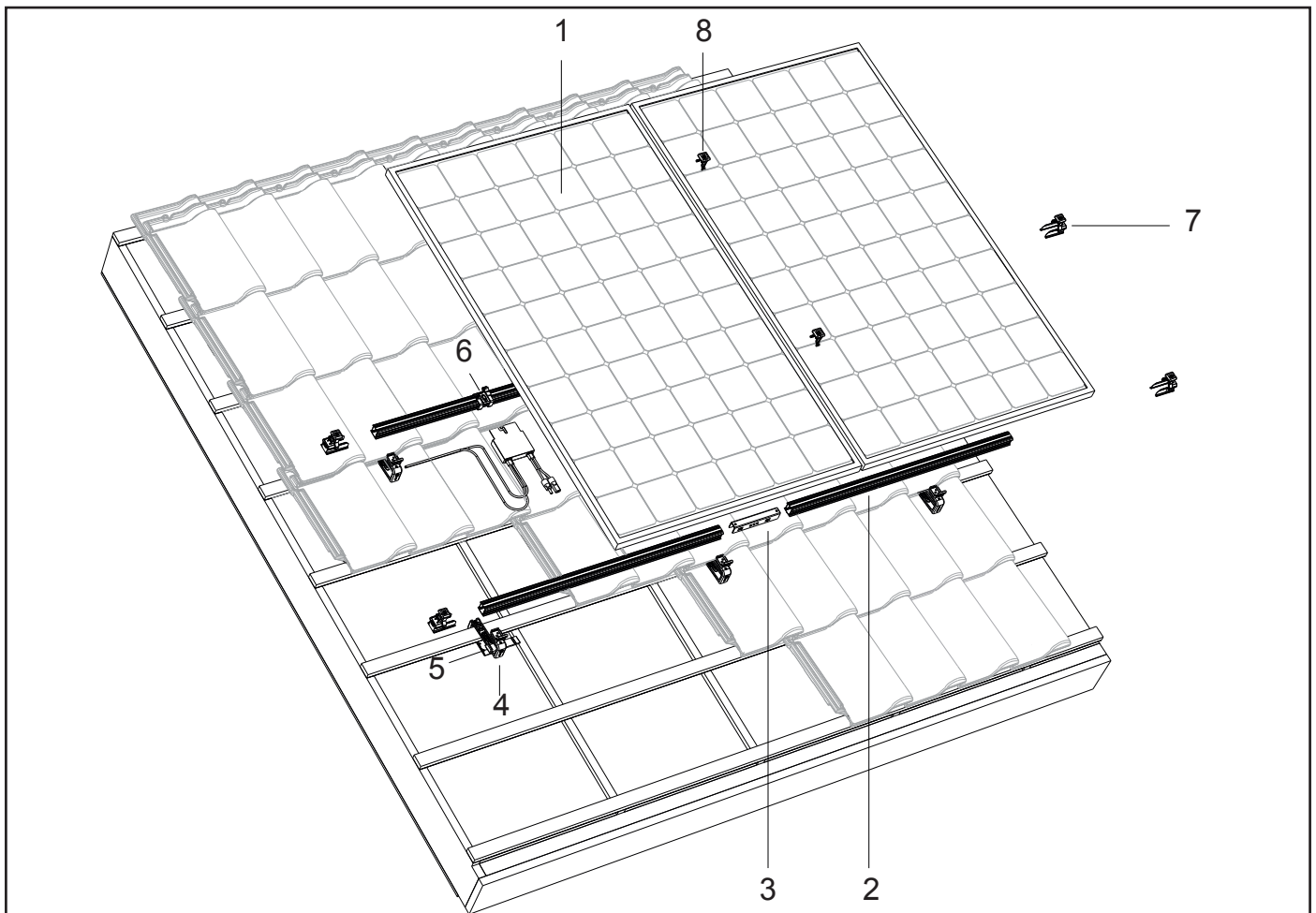

4.2 Exploded-view mounting system in landscape set-up

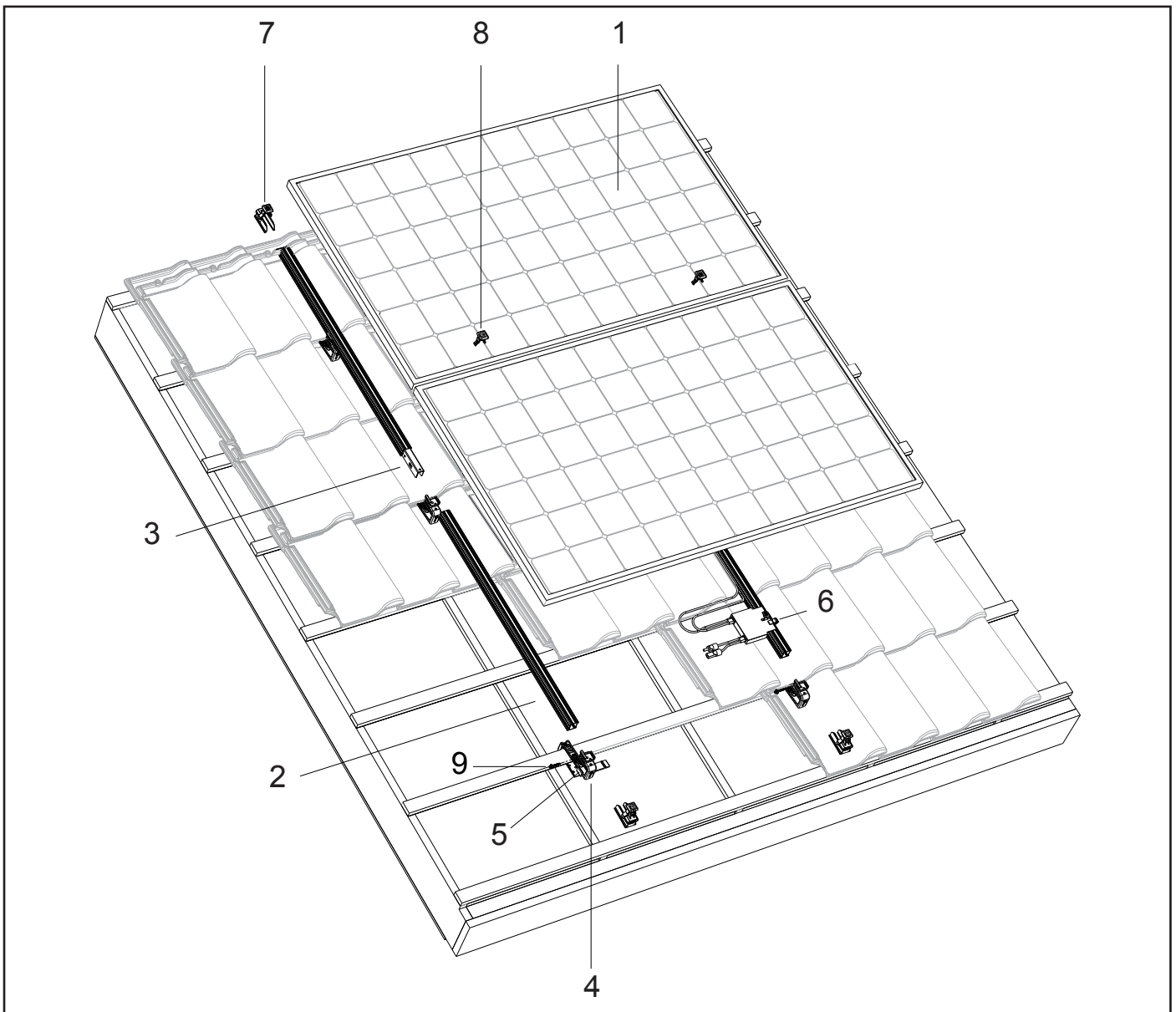

4.3 Universal roof hook for portrait or landscape set-up

The Universal roof hook is fitted with a rotatable click bracket, which enables the mounting rail to be clicked on both horizontally and vertically. This means that the roof hook can be used for both portrait and landscape set-ups.

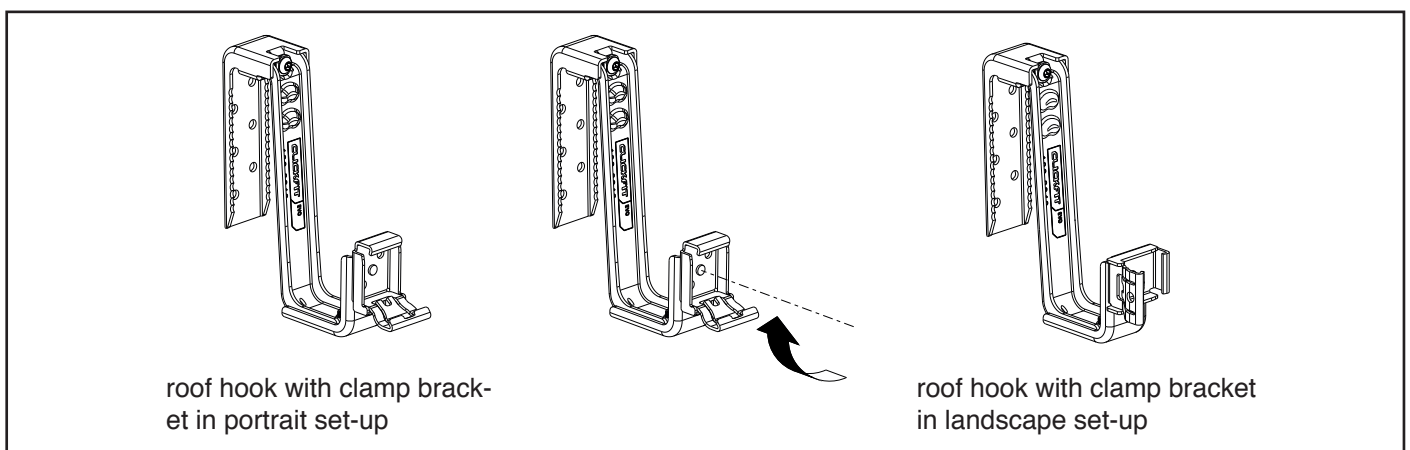

4.4 Parts list

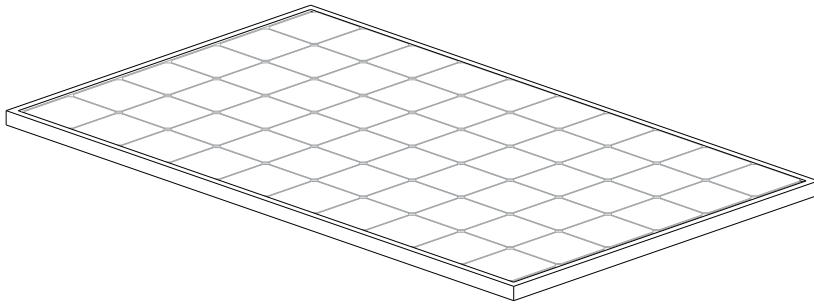

1. Solar panel

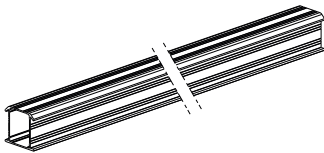

2. ClickFit Evo Mounting rail
Article no: 100800_ and 10081__

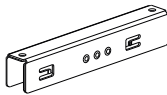

3. ClickFit Evo Mounting rail connector
Article no: 1008061

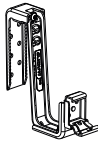

4. ClickFit Evo Roof hook universal
Article no: 1008040



5. ClickFit Evo EPDM roof hook spacer
Article no: 1008063



6. ClickFit Evo Mounting rail cable clip optimizer ready
Article no: 1008062



7. ClickFit Evo Mounting rail End cap grey
Article no: 1008060

7B. ClickFit Evo Mounting rail End cap black
Article no: 1008060-B



8. ClickFit Evo Module Clamp universal grey
Article no: 1008020

8B. ClickFit Evo Module Clamp universal black
Article no: 1008020-B



9. Self-tapping screw 6.3 x 32
Article no: 1003015
(With landscape)

5. Installation preparation

5.1 Check tools and accessories

Here is a list of the tools/aids required:

Marker / chalk

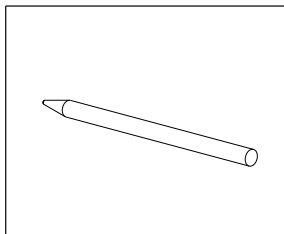

Brush

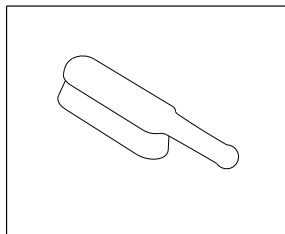

Tape measure

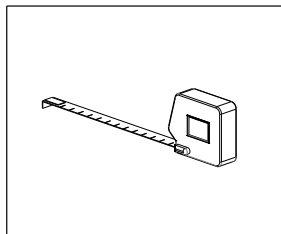

Battery-powered screwing drill

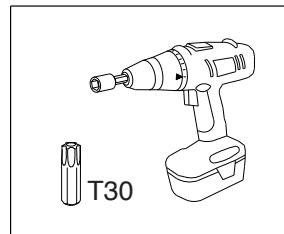

Metal saw

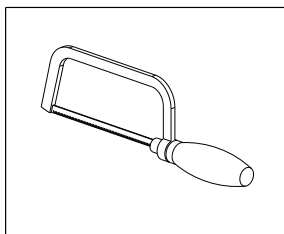

Safety gloves

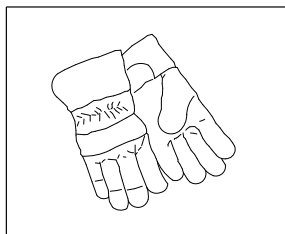

Safety helmet

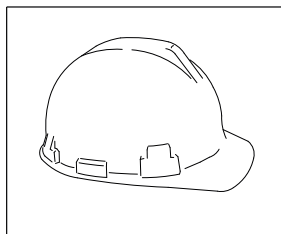

Safety glasses

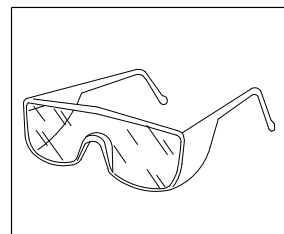

Safety clothes

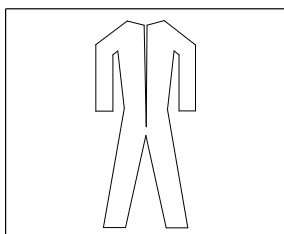

Safety shoes

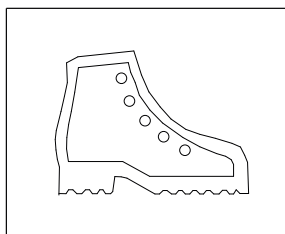

Dust mask

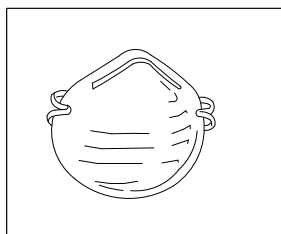

Hearing protection

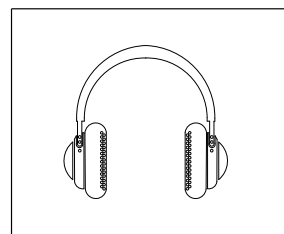

Scaffold or stable,
safe ladder

5.2 Clean the roof

Clean the tiles on the sloping roof with a brush.

Remove algae, moss, etc. in order to reduce unevenness during the installation to a minimum!

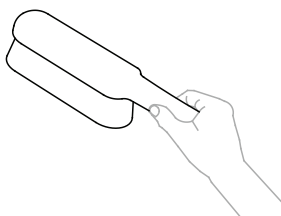

5.3 Determining and measuring the position of the solar panels

When determining the position of the solar panels on the sloping roof it is very important to pay attention to direction of the sunlight during the day and during the entire year. Place the panels on a roof surface that is not shaded. Shadows made by chimneys, dormer windows, trees and nearby buildings have a negative effect on the yield produced by the solar panels.

Measuring and marking

For the placement of the solar panel (in the portrait or landscape set-up) you require a space of approximately 160x80 cm or 160x100 cm or 200x100 cm per panel (depending on the type of solar panel).

Ensure that a buffer space of at least 30 cm is maintained around the solar panels on the roof. In other words, 30 cm from the ridge and the gutter and 30 cm from the sides, in connection with turbulent wind load.

Mark the contours of the panel field on the tiles with chalk or a marker.

Marking mounting rails and universal roof hooks for portrait set up:

Draw the lines where the mounting rails will be placed: at $\frac{1}{4}$ from the panel top edge and panel bottom edge.

Now mark where the universal roof hooks must be placed. The roof hook distance depends on a number of variables (wind load, building height, location, condition of the roof, etc). Follow the instructions of the calculator in relation to the distances between the roof hooks; this is of primary importance.

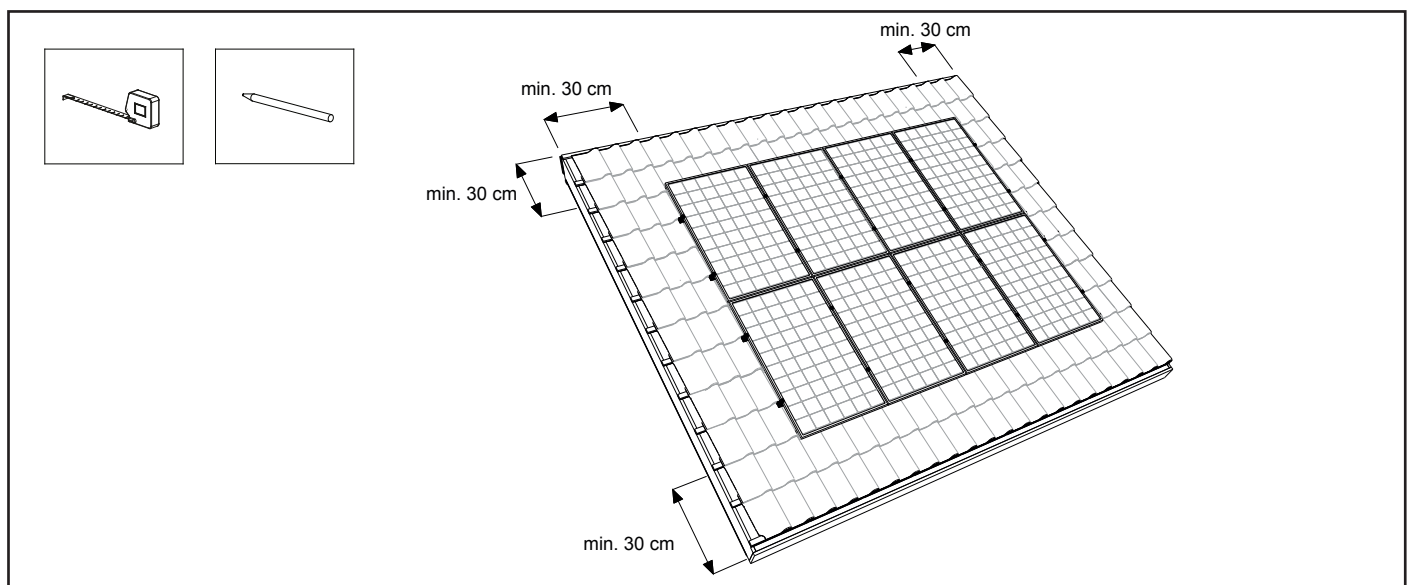

Marking mounting rails and Universal roof hooks for a landscape set-up:

Mark the lines where the mounting rails will be placed: at $\frac{1}{4}$ of the panel side edges. Now mark where the universal roof hooks must be placed.

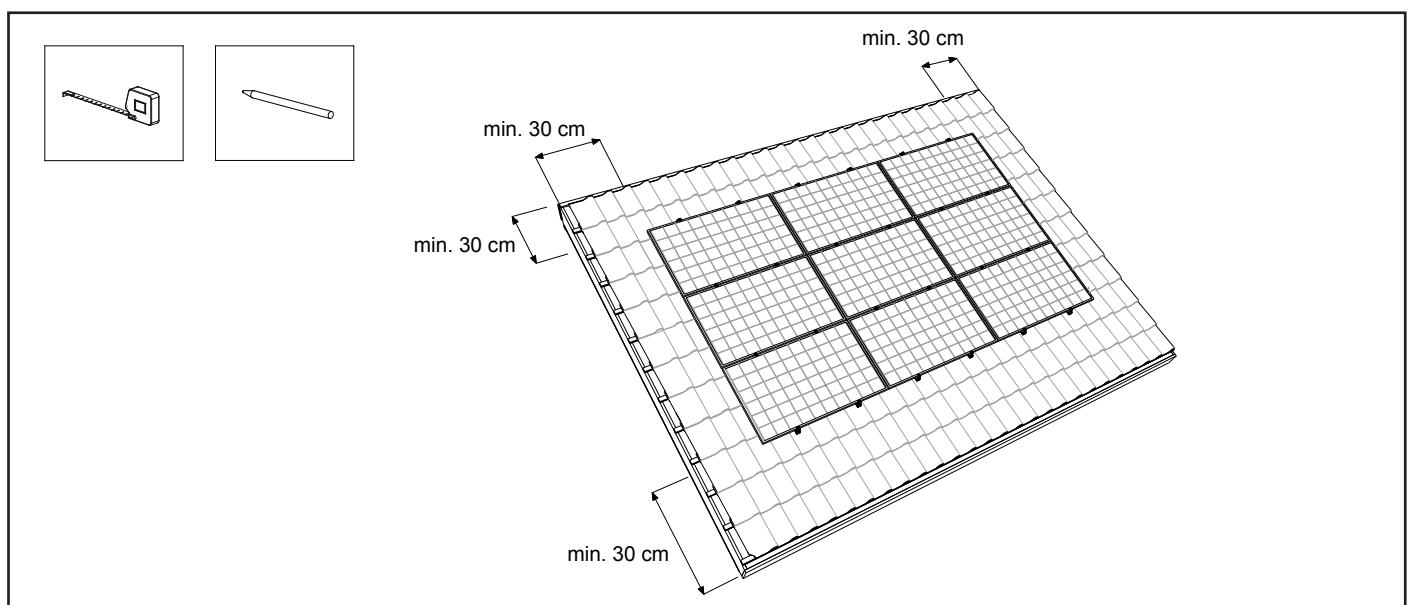

6. Installation of the mounting system in portrait set-up

6.1 Pre-mounting the mounting rail connector

First determine the total required rail length for the row of solar panels.

You can fasten the mounting rails to each other with mounting rail connectors. The mounting rail connector has clamps with teeth that grip the inside of the rail.

Slide the connector into the ends of the mounting rail. Slide the connector in up to the centre of the middle ridge of the connector.

Connect the number of rails to each other, until the total required rail length has been created.

Attention! See appendix for restrictions and other details.

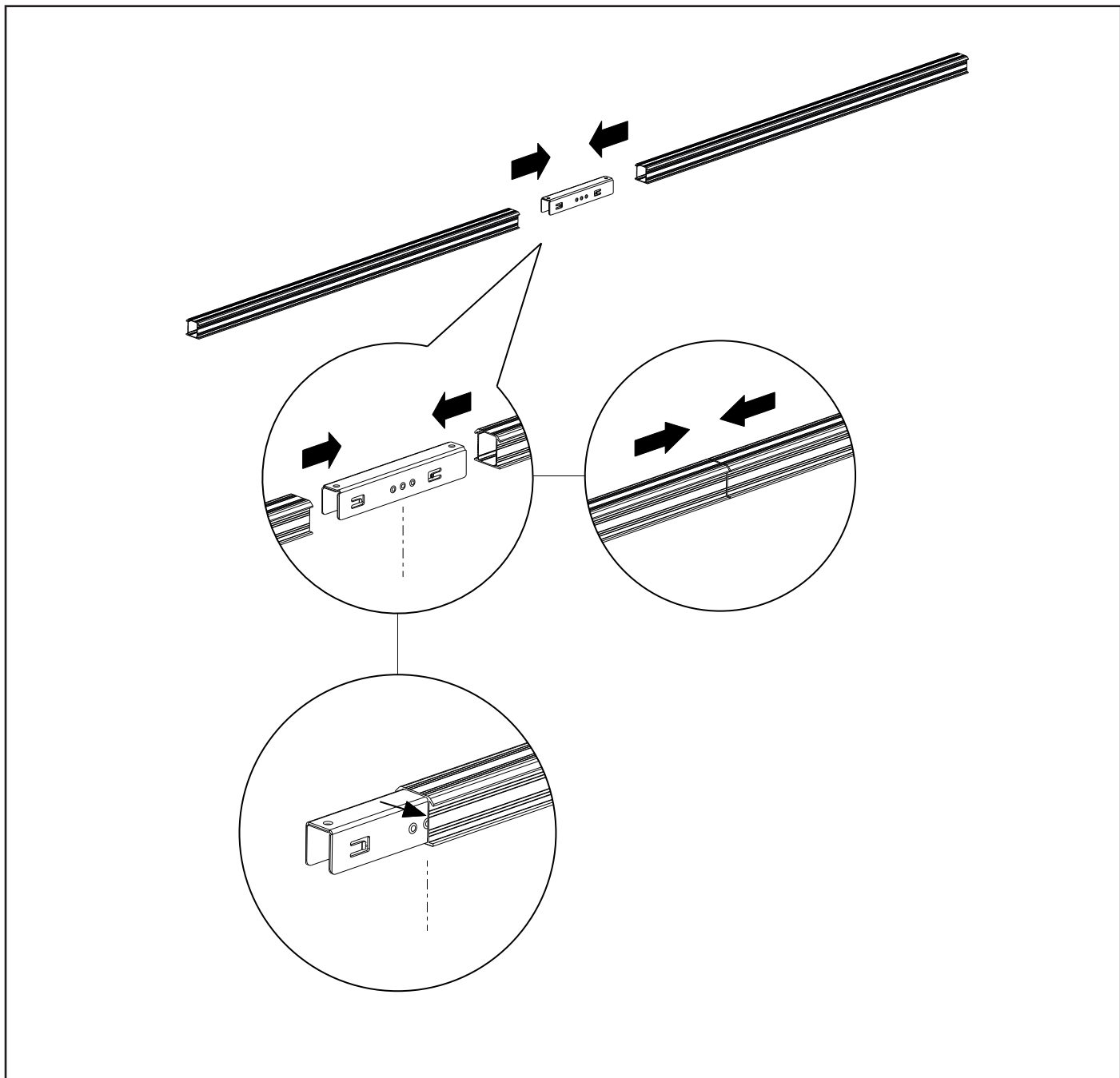

6.2 Fastening universal roof hooks

1. Slide the tile above the roof hook upwards, under the tile above it. Hook the top adjustable part of the roof hook behind the tile lath and tile and place the roof hook in the dip of the roof tile below it. The top adjustable part of the roof hook is a minimum of 32 mm and a maximum of 65 mm.
2. Tighten the torx screw at the top of the roof hook with a drill with a screw head until the roof hook clamps onto the tile lath/tile securely. **Attention!** The tightening moment of the screw connection is 4.5 Nm.
3. Slide the roof tile above the roof hook down again. With some roof tiles the top tile must be adjusted for the roof hook with an angle grinder or a file, so that the roof tiles fit correctly again.*
4. Follow the instructions of the calculator with regard to the distance between the roof hooks; this is of primary importance. Ensure that the roof hooks are aligned with each other.

*Option: For roof tiles with a high water-repellent edge, the filling rubber can be placed under the roof hook so that the roof hook rests neatly on the tile. Fold the rubber to create the desired thickness. The filling steps are 5, 10 and 15mm.

Attention! Ensure that the click bracket is in the correct position on every universal roof hook, so that the mounting rail can be fastened to the roof hook horizontally (see chapter 5.3).

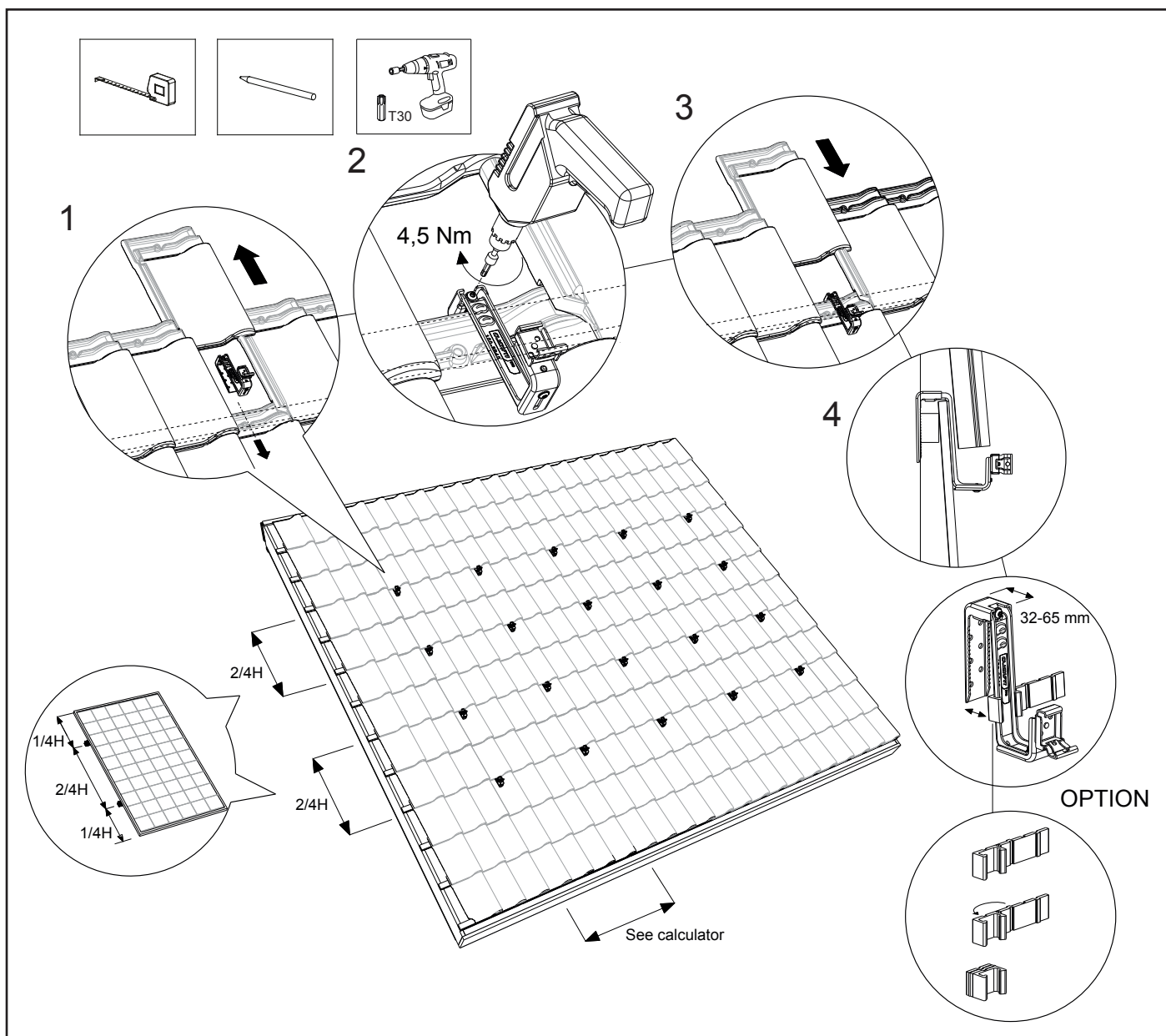

6.3 Fastening the mounting rail

1. Place the mounting rail in the mounted universal roof hooks.
2. Ensure that the end of the mounting rails protrude 90 - 250 mm in relation to the last roof hook.
3. Now click the mounting rail onto the universal roof hooks. Ensure that it clicks firmly into place.
4. Ensure that the mounting rail and the universal roof hook are correctly aligned to each other and the mounting rail is positioned correctly on the roof hook. Ensure that the mounting rails are directly above each other in connection with the alignment of the solar panels!
5. Where necessary, the mounting rail can be aligned by means of the height adjustment on the roof hook. Loosen the torx screw on the underside of the roof hooks a little. Set the desired height and tighten the torx screws again

Attention! The tightening moment of the screw connection is a minimum of 6 Nm.

Attention! See appendix for restrictions and other details.

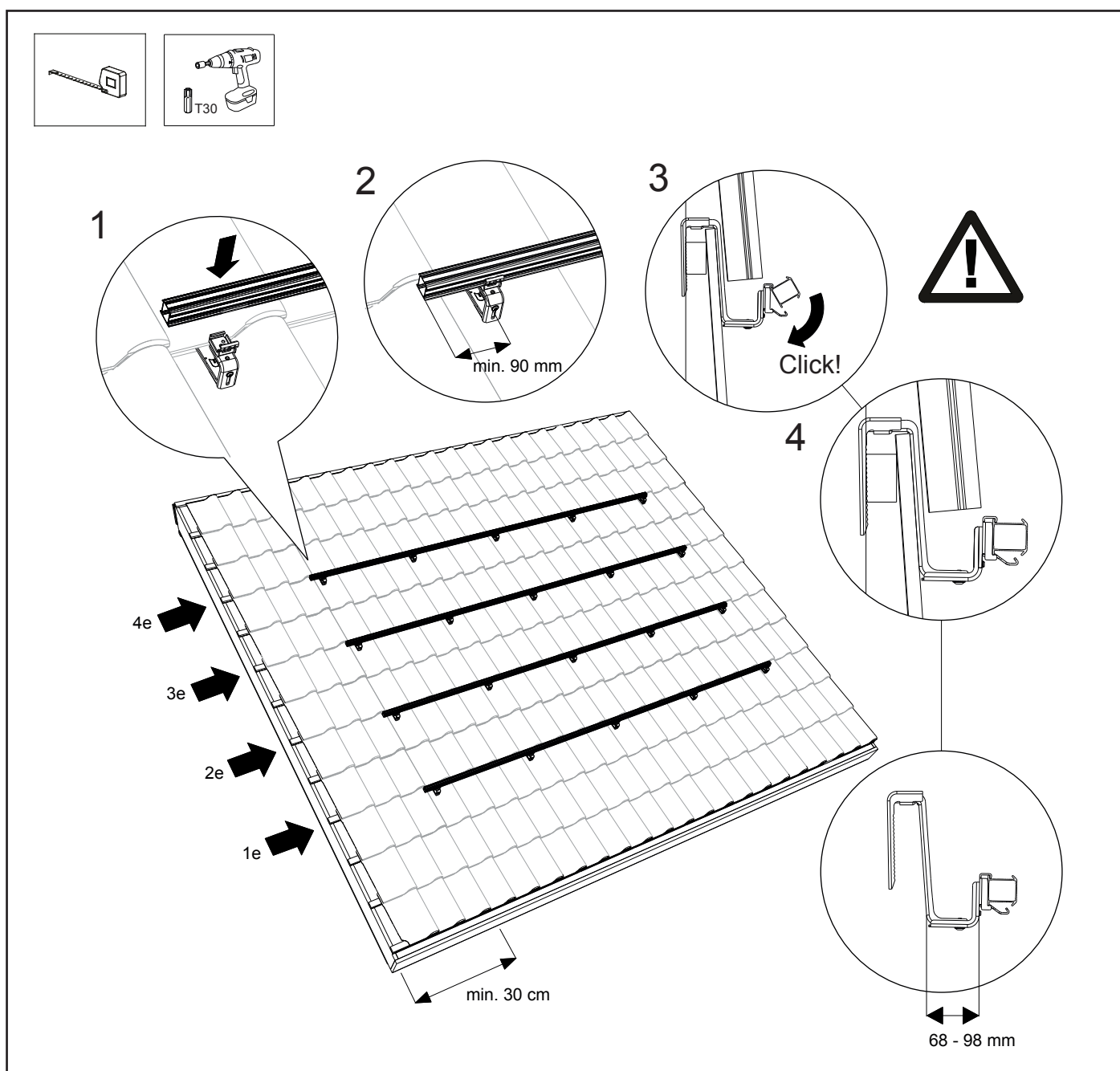

6.4 Installing the mounting rail cable clip optimizer ready and optimizer (option)

1. Position the cable clip on the top mounting rail of a row. One cable clip is applied per solar panel. The cable clips are positioned underneath the centre of a panel. Place the cable clips at a distance of approximately 1 metre from each other.
2. Click the cable clip firmly onto the mounting rails.
3. Guide the cabling through the click bracket of the universal roof hook and the cable clip.

Optional:

4. Click the optional optimizer onto the cable clip.
5. Lead the cables of the optimizer through the cable clip.

Attention! See appendix for restrictions and other details.

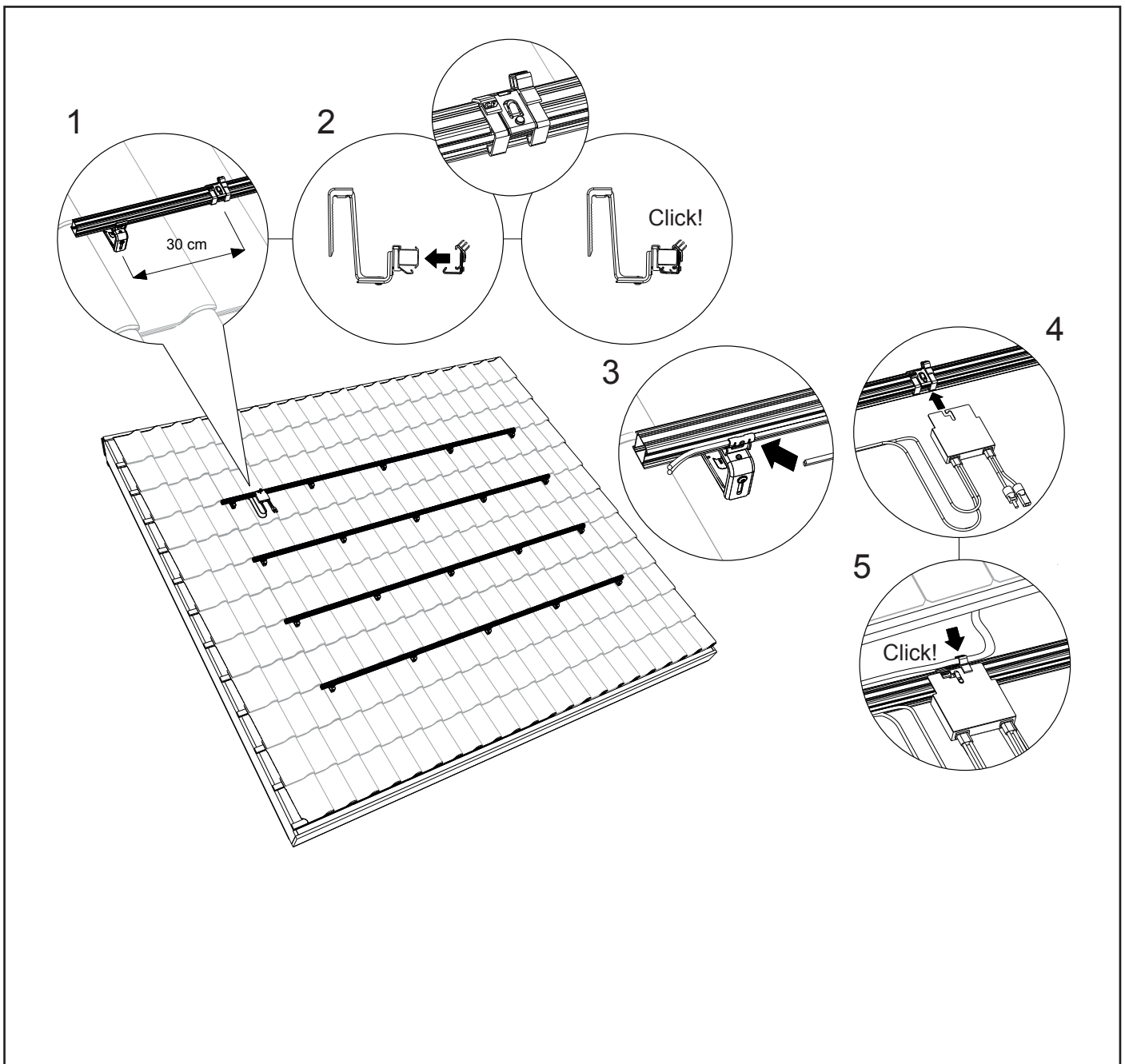

6.5 Mounting 1st solar panel on the mounting rail

Mounting aid (Option):

Click the mounting aid (2x) onto the frame on the back of the solar panel. To do this, use the mounting holes in the top of the frame.

Click the cables of the solar panel securely into the cable clamp on the mounting aid.

Hang the solar panel, including mounting aid, to the mounting rail. Click the cables of the solar panel in the cable clip that has already been placed. Slide the first solar panel to the side of the mounting rail. Allow 20 - 35 mm of rail to protrude visibly next to the solar panel.

Now slide the mounting rail end cap onto the mounting rail with the universal module (end) clamp. Choose the correct recess, so that the universal module clamp connects with the solar panel. Now tighten the universal module (end) clamp.

Attention! The tightening moment of the screw connection 4.5 Nm.

Attention! The minimum panel thickness $Y = 29$ mm and the maximum panel thickness $X = 50$ mm.

Attention! See appendix for restrictions and other details.

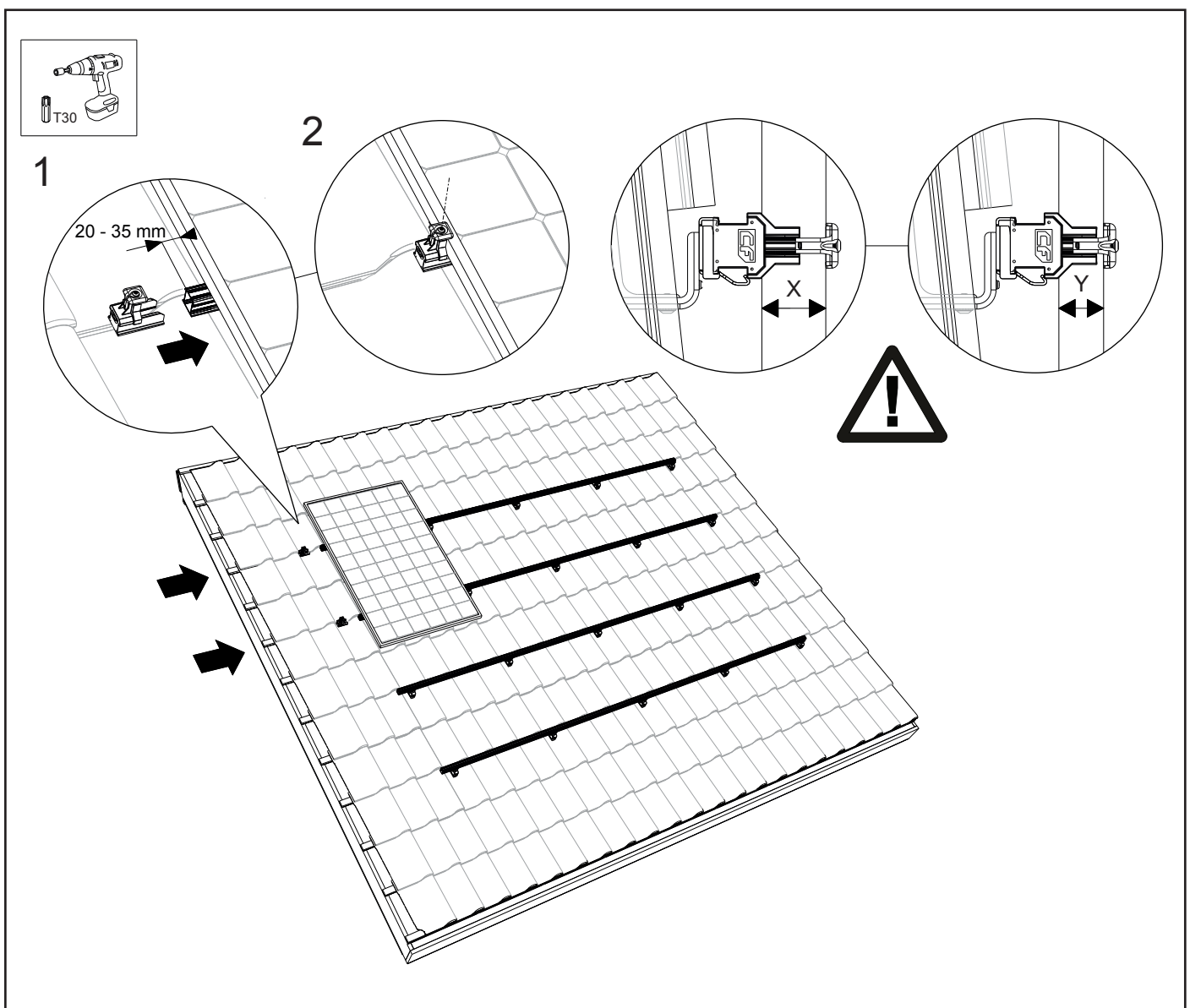

6.6 Mounting of other solar panels on the mounting rails

Click the universal module clamps onto the mounting rails. Slide them against the first solar panel. Place the second solar panel on the mounting rail, click the cables of the solar panel firmly into the cable clip and slide the solar panel to the first against the Universal module clamp. Now tighten the universal module clamp.

Attention! The tightening moment of the screw connection is 4.5 Nm.

Ensure that the solar panels are lying straight before you tighten the torx screw! Repeat this with the remaining solar panels.

Attention! See appendix for restrictions and other details.

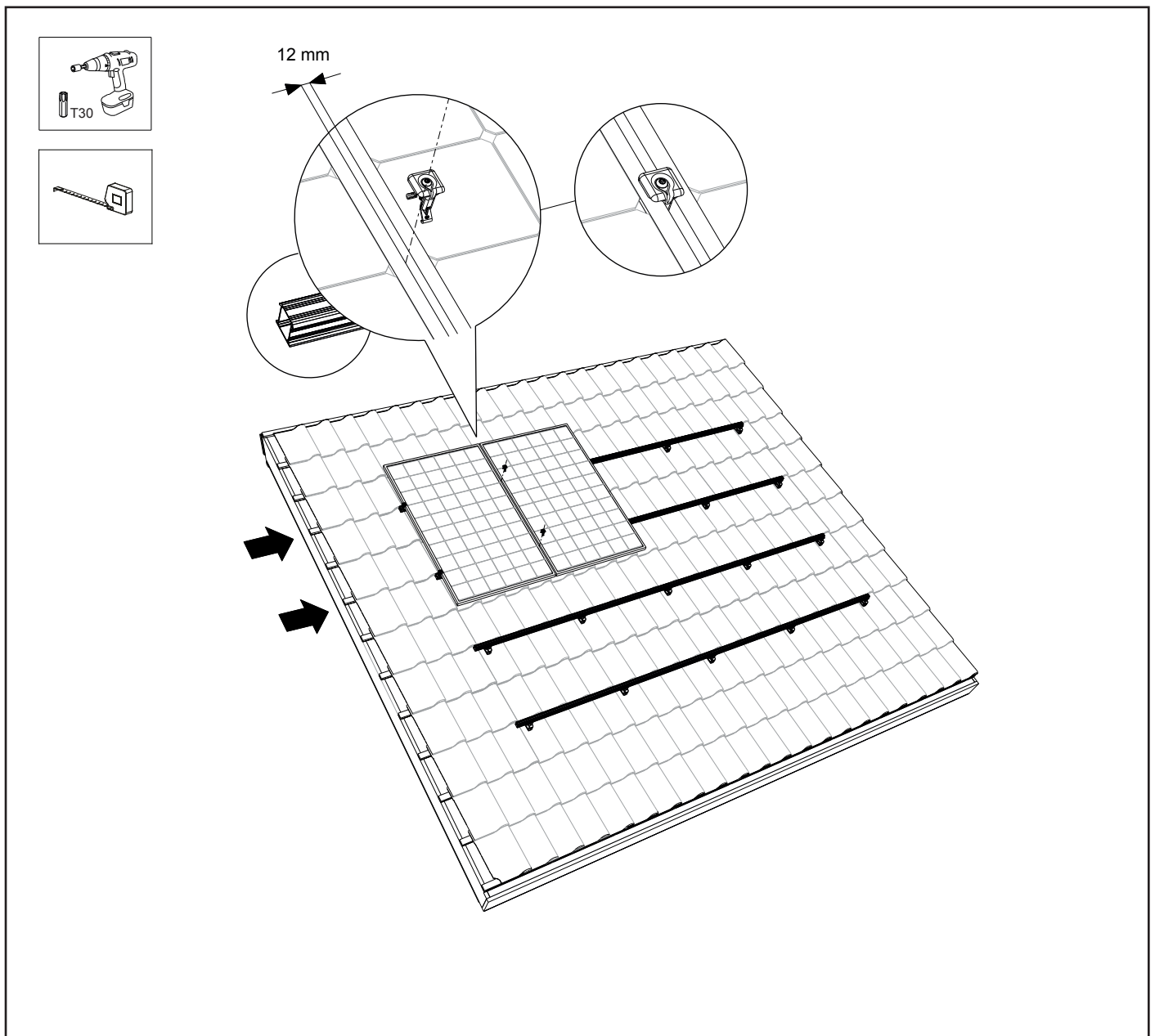

6.7 Completing the mounting of the 1st row of solar panels

1. Allow the mounting rail to protrude 20 - 35 mm in relation to the edge of the solar panel. Slide the mounting rail end cap onto the mounting rail with the universal module (end) clamp. Attention! Choose the correct recess, so that the end clamp connects with the solar panel.
2. Now tighten the end clamp with the torx screw. **Attention!** The tightening moment of the screw connection is 4.5 Nm.

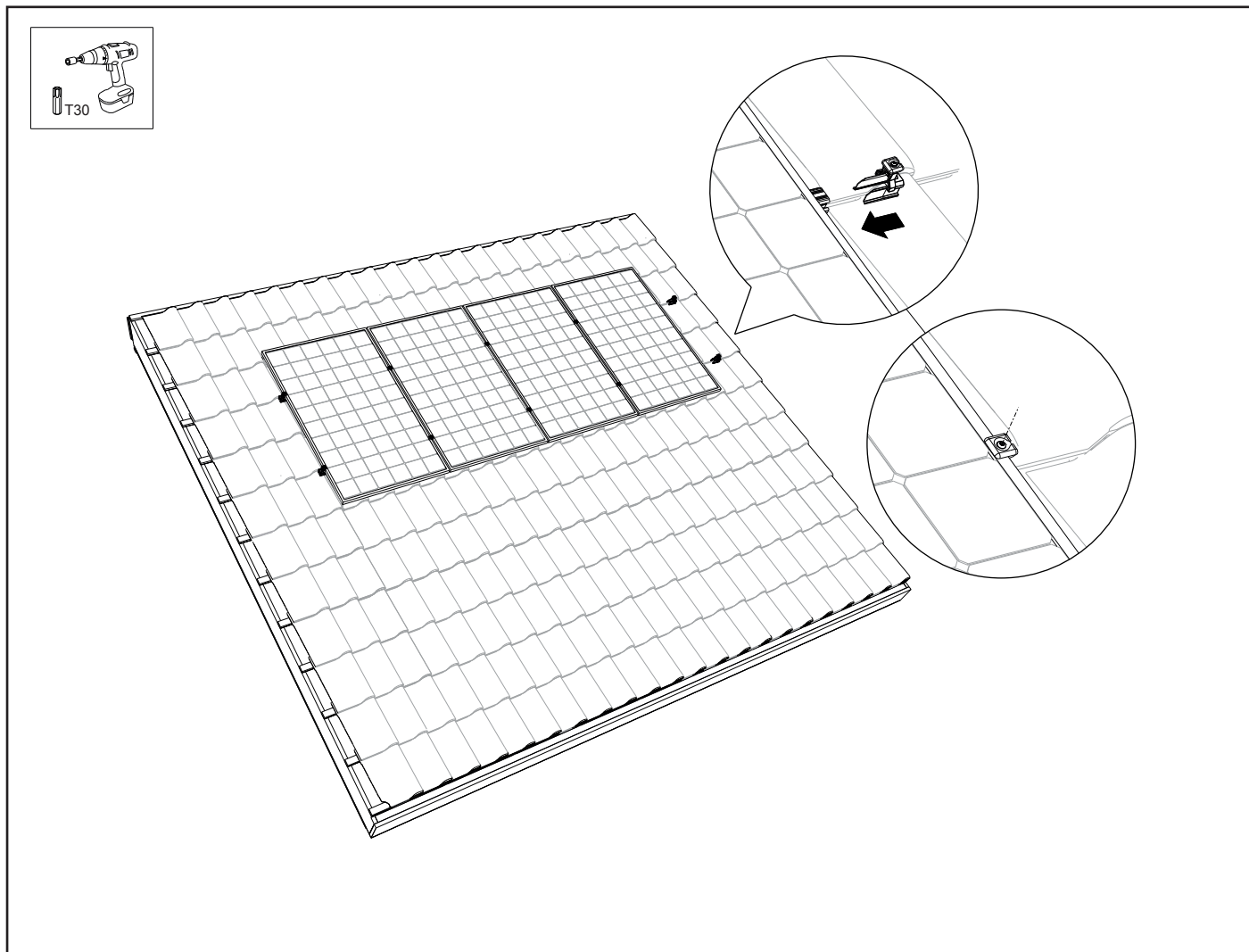

6.8 Completion of mounting / several rows below each other

1. In order to obtain a continuously connected panel area you slide the bottom solar panels against the top row of solar panels.
2. Repeat the steps of chapter 6.5 - 6.7. The panel field is now complete!

Attention! See appendix for restrictions and other details.

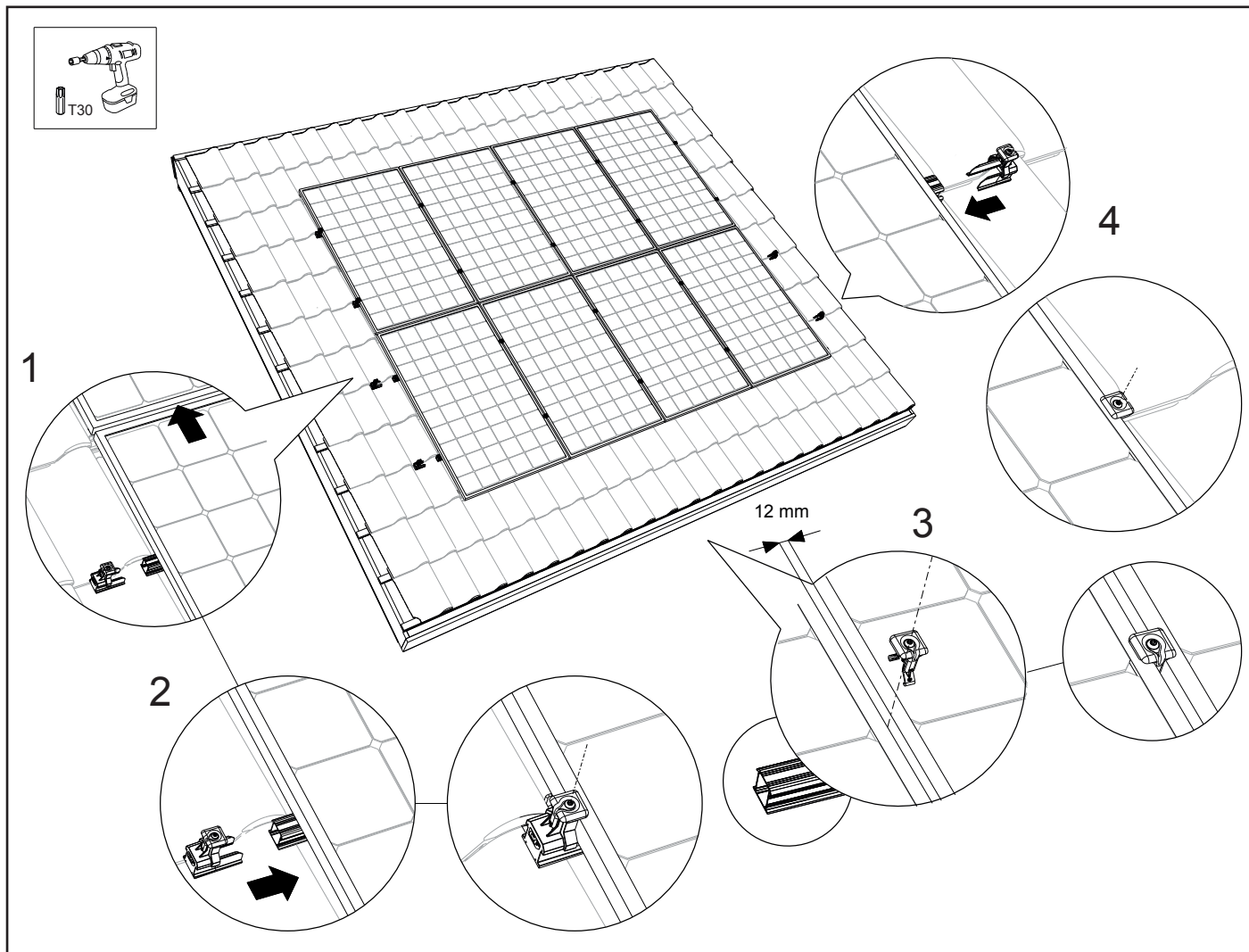

7. Installation of mounting system in a landscape set-up

7.1 Pre-installation of the mounting rail connector

First determine the total rail length required for all solar panels in a column.

You can connect the mounting rails to each other with mounting rail connectors. The mounting rail connectors are fitted with clamps that have teeth that grip the inside of the rail.

Slide the connector into the ends of the mounting rail. Slide the connector in up to the centre of the middle ridge of the connector.

Connect the number of rails to each other, until the total required rail length has been created.

Attention! See appendix for restrictions and other details.

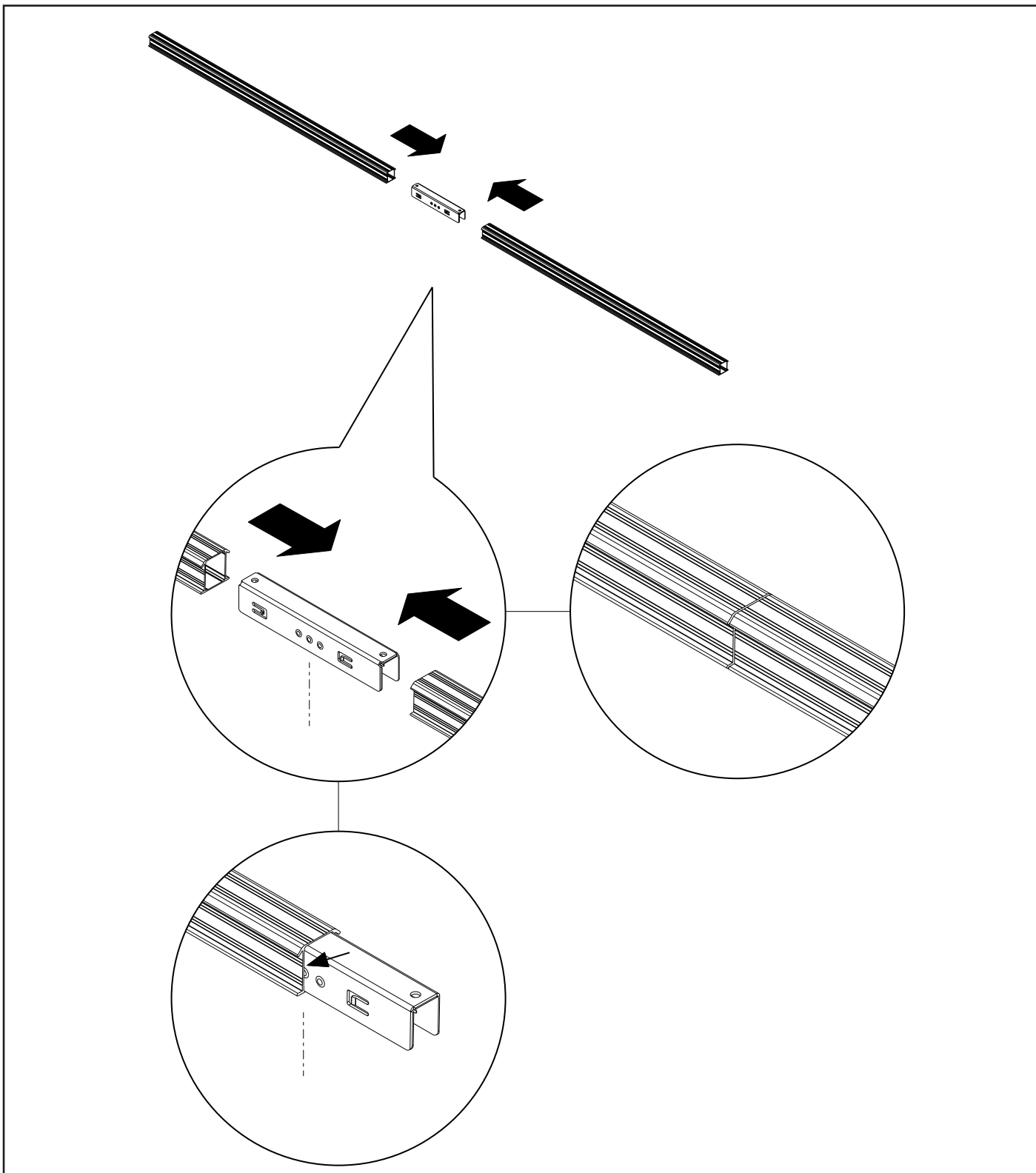

7.2 Fastening universal roof hooks

1. Slide the tile above the roof hook upwards, under the tile above it. Hook the top adjustable part of the roof hook behind the tile lath and place the roof hook in the depression of the roof tile below it. The top adjustable part of the roof hook is a minimum of 32 mm and a maximum of 65 mm.
2. Tighten the torx screw on the top of the roof hook with a drill fitted with a screw head until the roof hook clamps firmly to the tile lath/roof tile. **Attention!** The tightening moment of the screw connection is 4.5 Nm.
3. Slide the roof tile above the roof hook down again. For some roof tiles, the top tile must be adjusted for the roof hook with an angle grinder or a file, so that the roof tiles fit correctly again.*
4. Follow the instructions of the calculator in relation to the distance between the roof hooks; this is of primary importance. Ensure that the roof hooks are aligned with each other.

*Option: For roof tiles with a high, water repellent edge the filling rubber can be placed under the roof hook so that the roof hook rests neatly on the roof tile. Fold the rubber in order to create the desired thickness. The filling steps are 5, 10 and 15mm.

Attention! Ensure that the click bracket is in the correct position on every universal roof hook so that the mounting rail can be fitted vertically to the roof hook (see chapter 5.3.).

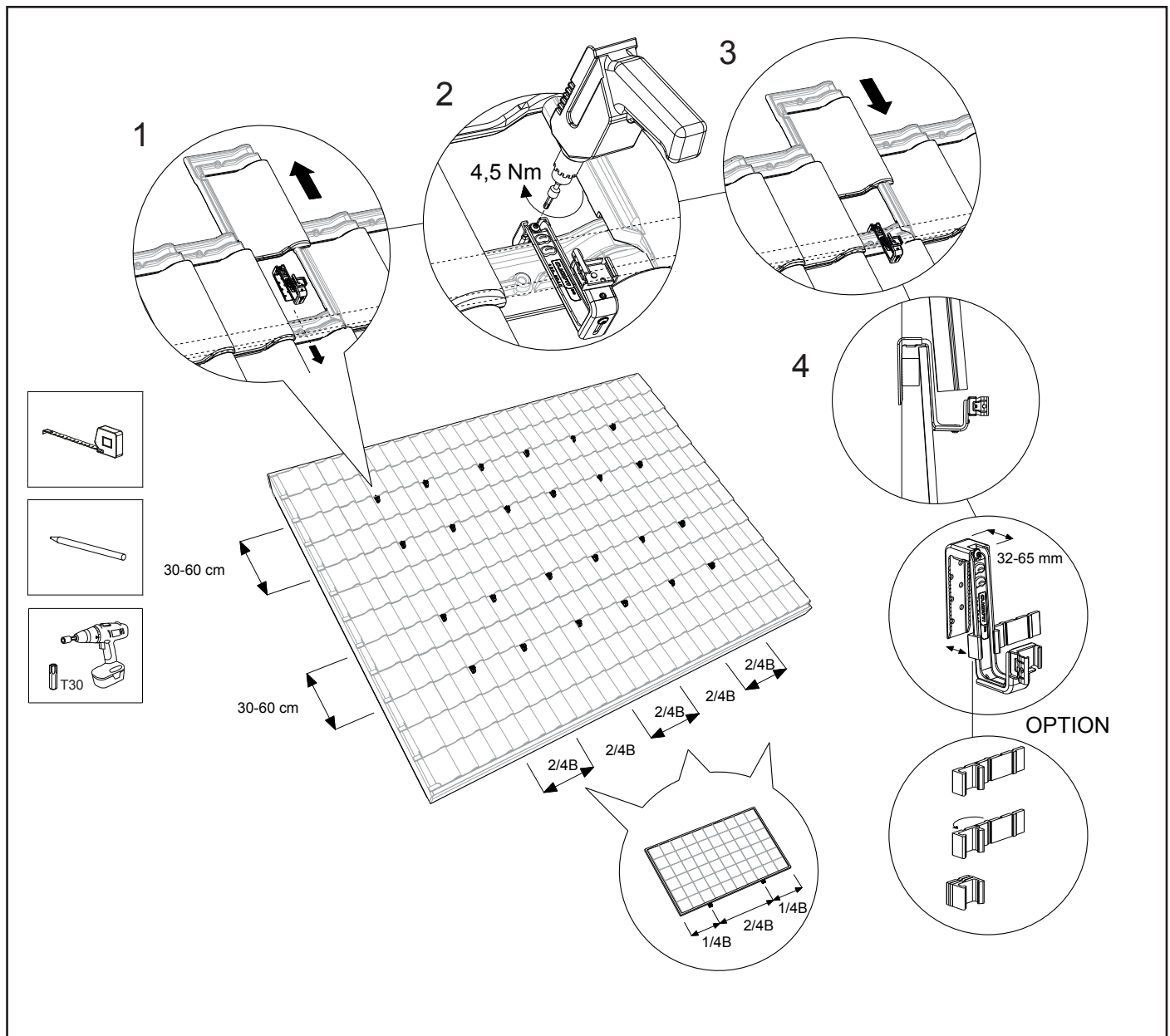

7.3 Fastening the mounting rail

1. Place the mounting rail in the placed universal roof hooks.
2. Ensure that the end of the mounting rails protrudes 90 - 250 mm in relation to the last roof hook.
3. Now click the mounting rail onto the universal roof hooks. Ensure that it clicks firmly into place.
4. Ensure that the mounting rail and the universal roof hook are correctly aligned to each other and the mounting rail is positioned correctly on the roof hook. Ensure that the mounting rails are aligned to each other horizontally in connection with the alignment of the solar panels!

Where necessary, the mounting rails can be aligned by means of the height adjustment of the roof hook. Loosen the torx screw on the bottom of the roof hooks. Set the desired height and tighten the torx screws again. **Attention!** The tightening moment of the screw connection is a minimum of 6 Nm.

5. Fasten the mounting rails to the bottom roof hook with a self-tapping screw 6.3 x 32 in order to prevent the rails from sliding down. **Attention!** Place this locking screw around the three solar panels (one above the other) and always start at the bottom roof hook.

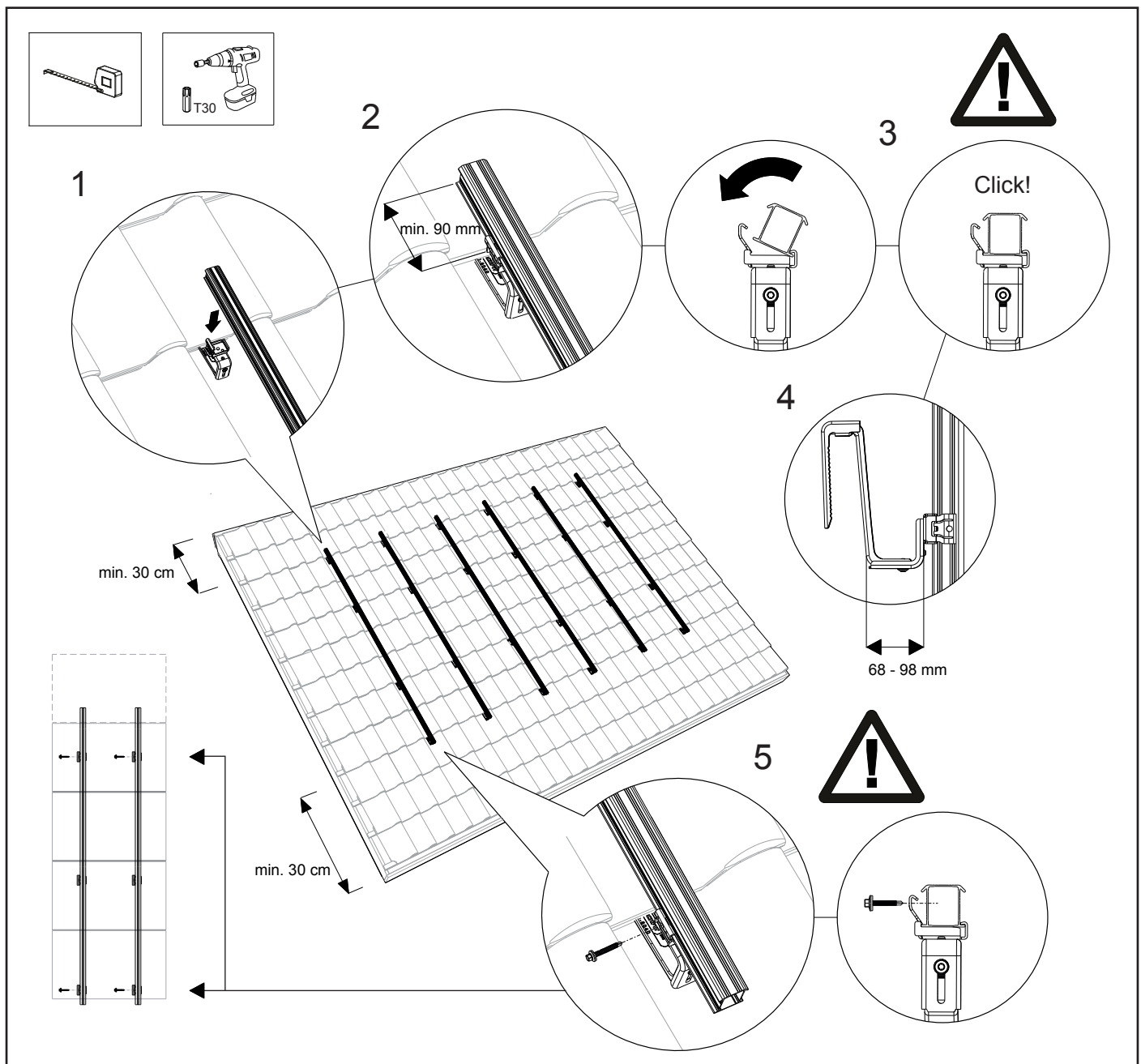

7.4 Installing the mounting rail cable clip optimizer ready and optimizer (option)

1. Position the cable clip on the mounting rail of a row. One cable clip is used per solar panel. The cable clips are positioned underneath the centre of the panel. Place the cable clips approximately 1 metre from each other.
2. Click the cable clip firmly onto the mounting rails.
3. Lead the cabling through the click bracket of the universal roof hook and the cable clip.

Optional:

4. Click the optional optimizer onto the cable clip.
5. Guide the cables of the optimizer through the cable clip.

Attention! See appendix for restrictions and other details.

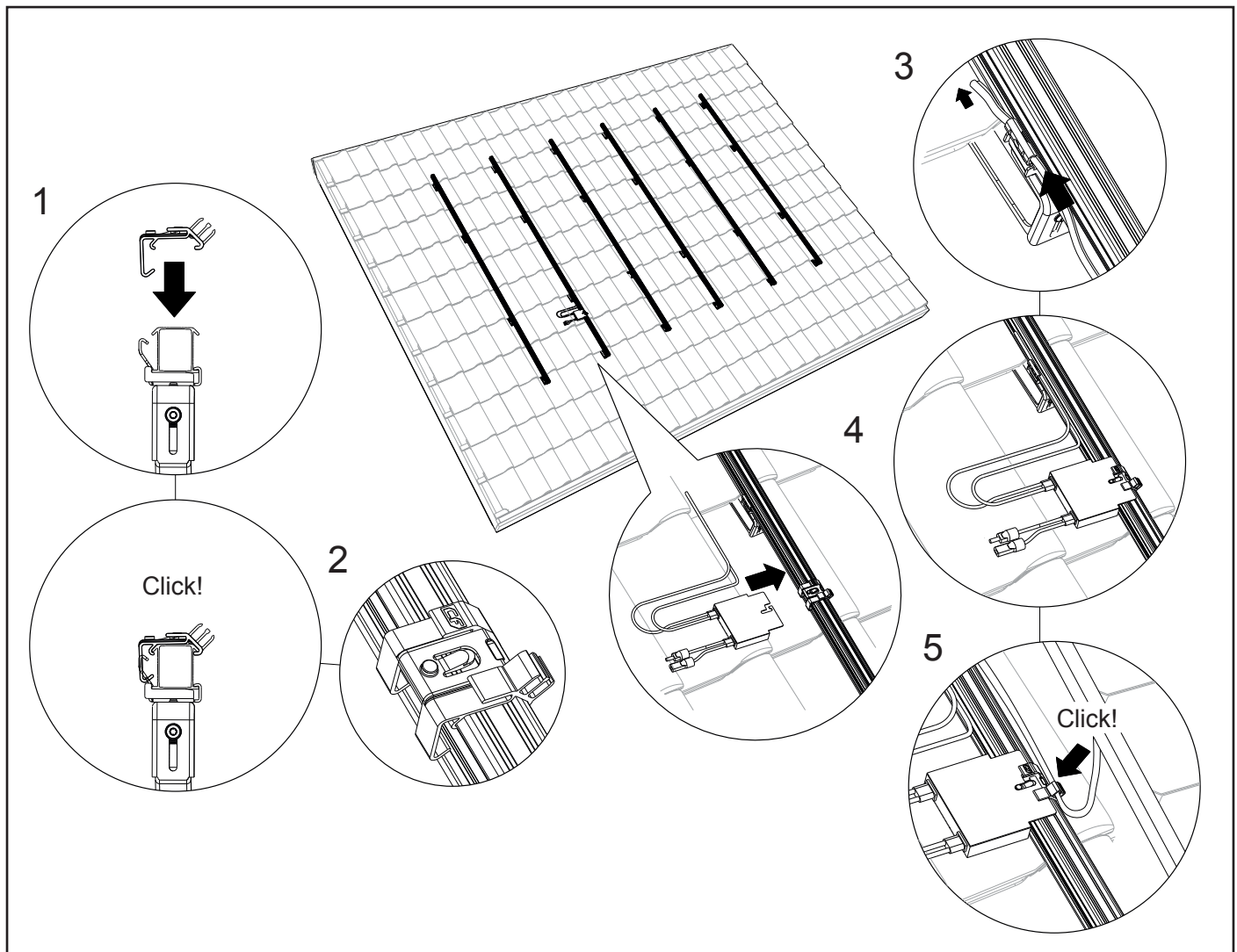

7.5 Mounting 1st solar panel on the mounting rail

Hang the solar panel on the mounting rail. Click the cables of the solar panel into the pre-installed cable clip.
Slide the first solar panel to the bottom of the mounting rail. Allow 20 - 35 mm rail to protrude under the solar panel.
Now slide the mounting rail end cap onto the mounting rail with the universal module (end) clamp. Choose the correct recess, so that the universal module clamp connects with the solar panel. Now tighten the universal module (end) clamp.
Attention! The tightening moment of the screw connection is 4.5 Nm.

Attention! The minimum panel thickness $Y = 29$ mm and the maximum panel thickness $X = 50$ mm.

Attention! See appendix for restrictions and other details.

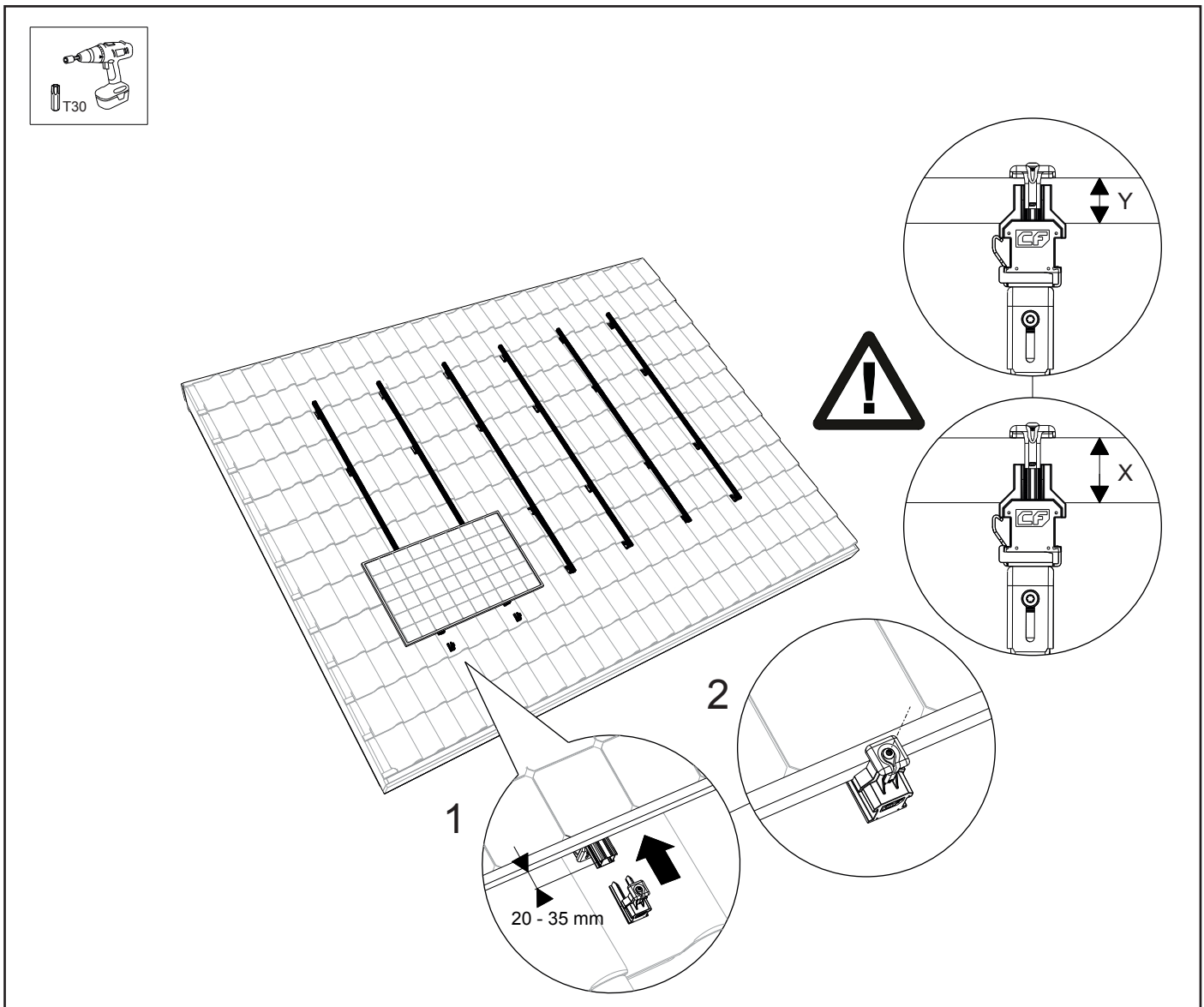

7.6 Mounting other solar panels on the rails

Click the universal module clamps onto the mounting rails. Slide it against the first solar panel. Place the second solar panel on the mounting rail, click the cables of the solar panel into the cable clip and slide the solar panel to the first, against the Universal module clamp. Now tighten the universal module clamp.

Attention! The tightening moment of the screw connection is 4.5 Nm.

Ensure that the solar panels are completely straight before you tighten the torx screw! Repeat this with the remaining solar panels.

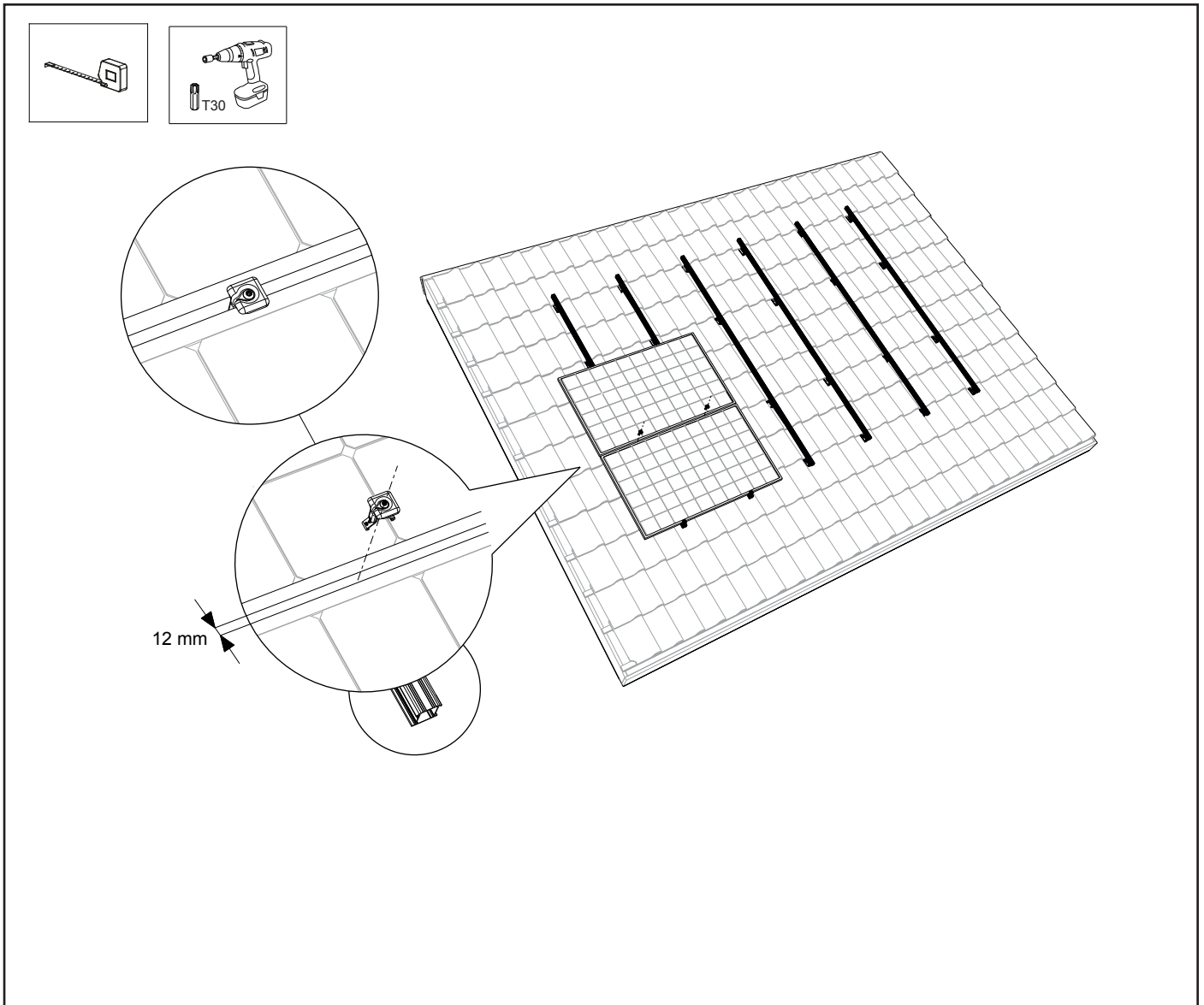

7.7 Completing the mounting of the 1st row of solar pan-

1. Allow the mounting rail to protrude 20 - 35 mm in relation to the edge of the solar panel. Slide the mounting rail end cap with universal module (end) clamp onto the mounting rail. Attention! Choose the correct recess, so that the end clamp connects to the solar panel.
2. Now tighten the end clamp with the torx screw. **Attention!** The tightening moment of the screw connection is 4.5 Nm.

Attention! See appendix for restrictions and other details.

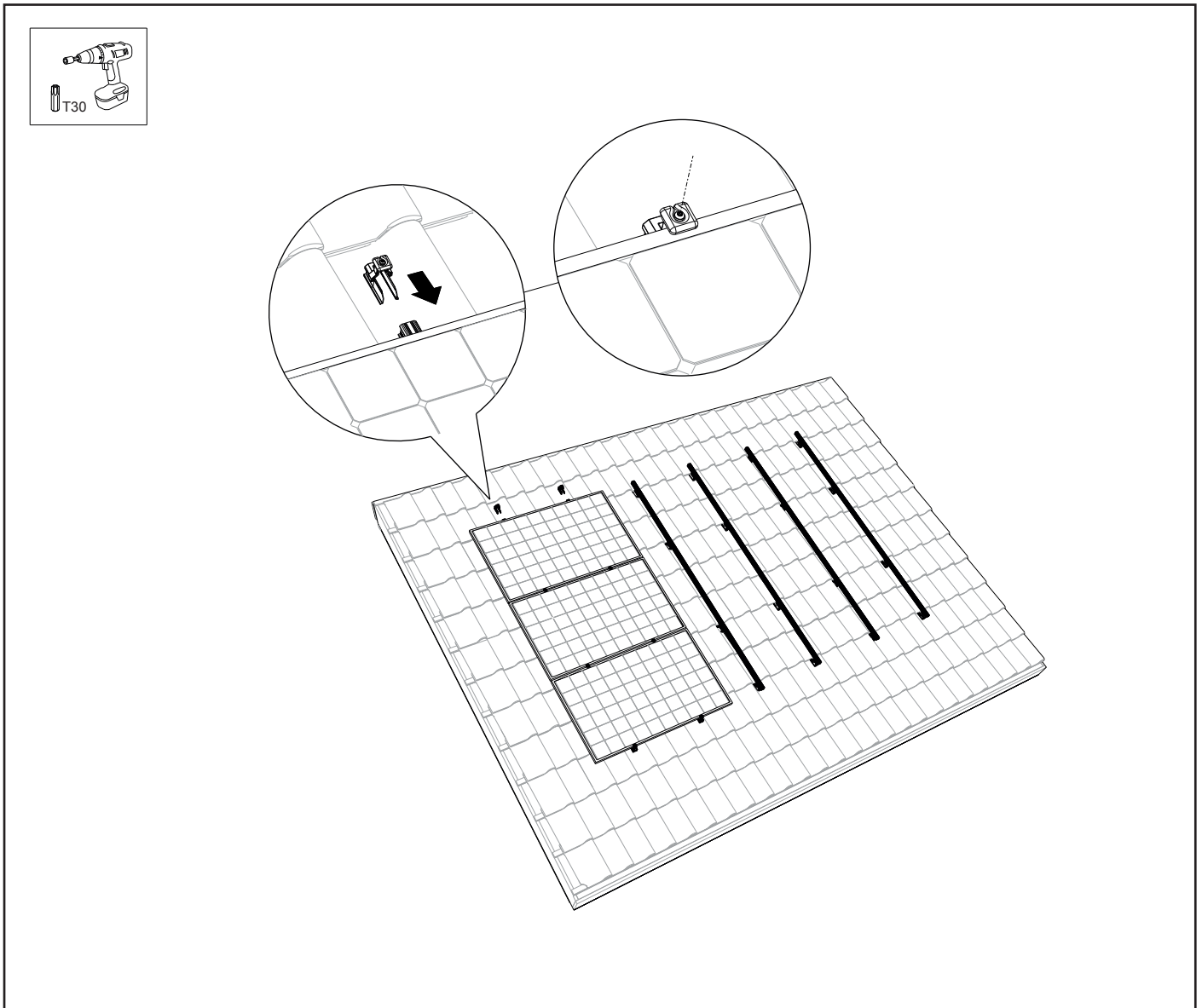

7.8 Completion of installation / several rows alongside each other

1. In order to obtain an uninterrupted solar panel field you slide the adjacent solar panels against the row of solar panels.
2. Repeat the steps of chapter 7.5 - 7.7. The panel field is now complete!

Attention! See appendix for restrictions and other details.

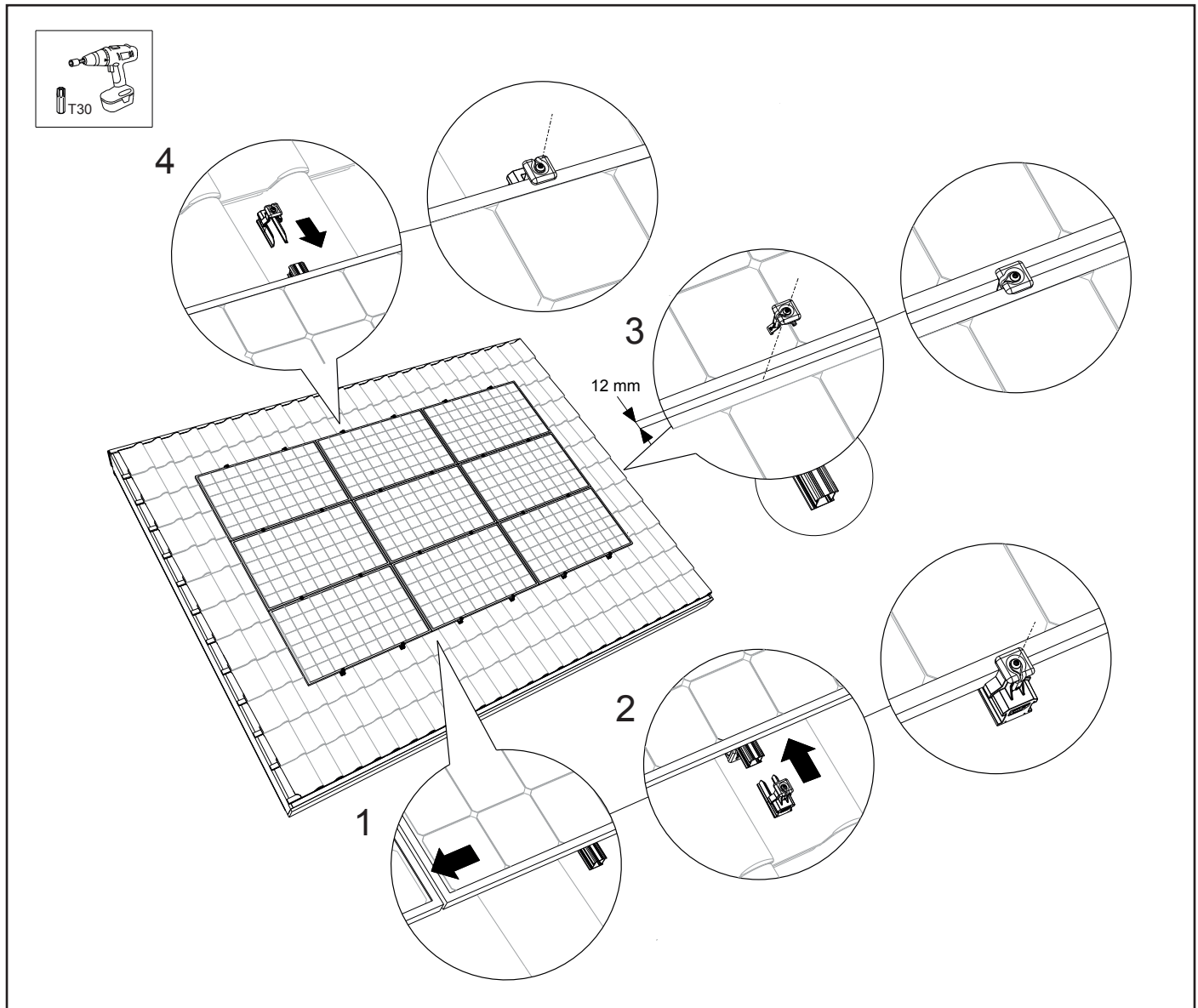

8. APPENDIX

8.1 Specifications for installation

8.1 - 01

Slide the connector into the ends of the mounting rails. Slide the connector up to the centre of the middle ridge of the connector. This divides the connector evenly over the 2 rail ends.

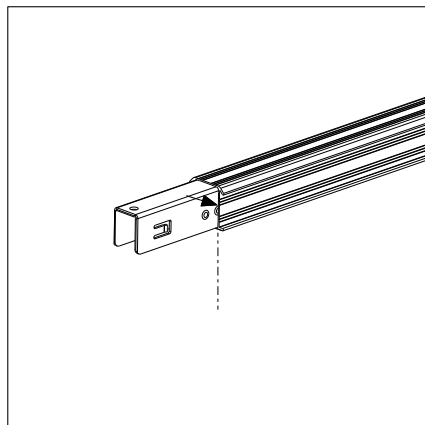

8.1 - 02

The first universal roof hook must be a minimum of 90 mm from the end of the mounting rail and a maximum of 250 mm.

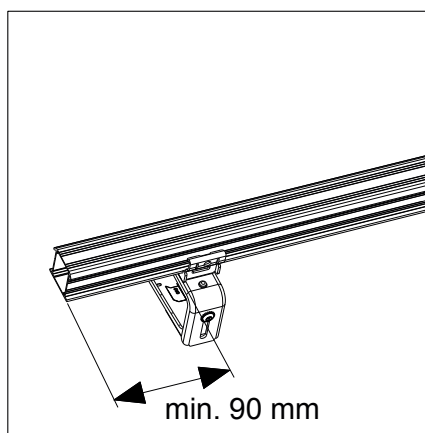

8.1 - 03

The mounting rails must protrude 20 - 35 mm in relation to the edge of the solar panel.

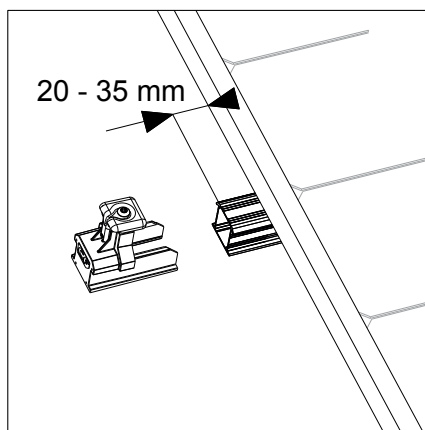

8.1 - 04

The mounting rails must protrude 20 - 35 mm in relation to the edge of the solar panel. Saw the mounting rails off at the correct length.

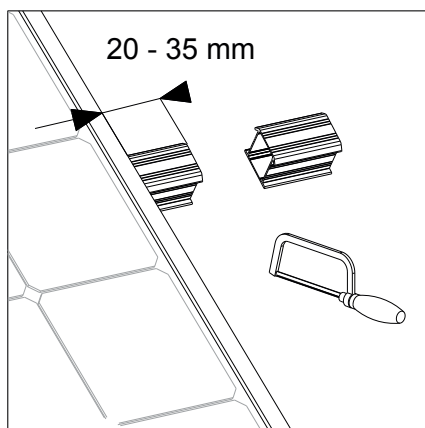

8.1 - 05

The universal roof hook must be mounted at least 90 mm from the end of the mounting rail and a maximum of 250 mm.

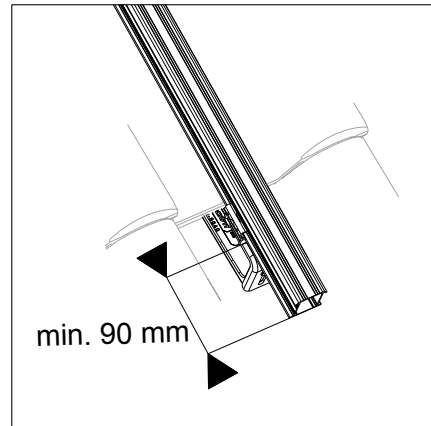

8.1 - 06

The mounting rails must protrude 20 - 35 mm in relation to the edge of the solar panel.

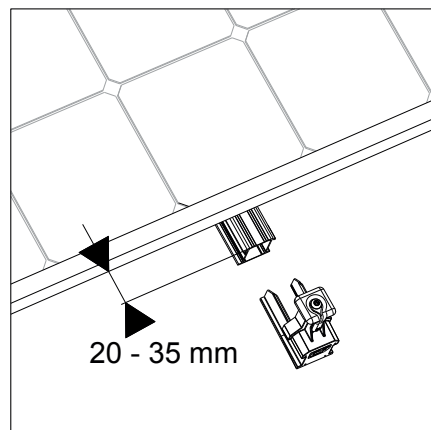

8.2 Tightening moments

Screws to fasten roof hooks (= screw on the top of the roof hook):

4,5 Nm

Screws for roof hook height adjustment (= screw on the bottom of the roof hook):

minimum 6,0 Nm

Screws for fastening the module clamp:

4,5 Nm