



Logic Air.

PRE-PLUMBED DHW CYLINDERS
WITH INTEGRATED BUFFER



Single and two zone options



Industry leading reheat times



25 year warranty*



Fully pre-plumbed and pre-wired



Factory fitted control box



Highly Efficient multi-coil heat exchanger



Technical Specification.

PRE-PLUMBED DHW CYLINDERS WITH INTEGRATED BUFFER - SINGLE ZONE

		LOGIC AIR DHW CYL PP 180 CBOX BUFF 1Z	LOGIC AIR DHW CYL PP 210 CBOX BUFF 1Z	LOGIC AIR DHW CYL PP 250 CBOX BUFF 1Z	LOGIC AIR DHW CYL PP 300 CBOX BUFF 1Z
Ideal Product Code		236206	236208	236210	236212
Energy efficiency class		B	B	B	B
Heat Loss	Watts/h	49	55	62	68
Capacity (DHW content)	Litres	171	199	239	287
Volume of integrated buffer	Litres	70	70	63.5	63.5
Weight empty	Kg	64.6	68.6	77	87
Weight full	Kg	305.6	337.4	379	437.5
Overall width	mm	644	644	705	705
Overall height	mm	1907	2095	1908	2128
Overall depth	mm	702	702	780	780
Cylinder diameter	mm	550	550	630	630
Cylinder height	mm	1829	2017	1829	2049
Primary heat exchanger surface area	m ²	2.5	2.5	2.5	3.0
Heat up time from 10°C to 50°C	Min	22.17	32.71	26.56	44.09
Immersion heater rating	kW	3	3	3	3
Secondary return connection	No/Yes	No	Yes	Yes	Yes

*Heat Up Time, HWA Heat Pump Test 002:2020 (flow rate 0.42l/s and flow temperature of 55°C).

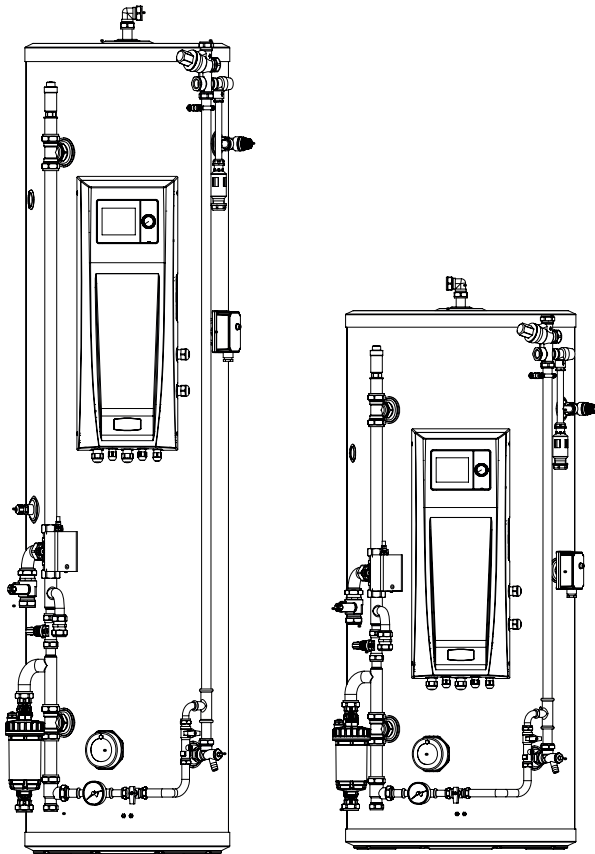

INCLUDES

- Control Box
- Buffer Tank
- Heat Pump Filter
- DHW 3-port Valve
- P&T Valve
- High Temp Cut Out
- Expansion Vessel
- Pressure Gauge
- Automatic Air Vent(s)
- Isolation Valves
- 3kW Immersion
- Circulation Pump(s)
- Flow & Return Thermistors
- DHW Thermistor
- Outdoor Sensor

Technical Specification.

PRE-PLUMBED DHW CYLINDERS WITH INTEGRATED BUFFER - TWO ZONE

		LOGIC AIR DHW CYL PP 180 CBOX BUFF 2Z	LOGIC AIR DHW CYL PP 210 CBOX BUFF 2Z	LOGIC AIR DHW CYL PP 250 CBOX BUFF 2Z	LOGIC AIR DHW CYL PP 300 CBOX BUFF 2Z
Ideal Product Code		236207	236209	236211	236213
Energy efficiency class		B	B	B	B
Heat Loss	Watts/h	49	55	62	68
Capacity (DHW content)	Litres	171	199	239	286
Volume of integrated buffer	Litres	70	70	63.5	63.5
Weight empty	Kg	68	71.8	80	90.2
Weight full	Kg	309	340.6	382	439.7
Overall width	mm	644	644	705	705
Overall height	mm	1907	2095	1908	2128
Overall depth	mm	702	702	780	780
Cylinder diameter	mm	550	550	630	630
Cylinder height	mm	1829	2017	1829	2049
Primary heat exchanger surface area	m ²	2.5	2.5	2.5	3.0
Heat up time from 10°C to 50°C	Min	22.17	32.71	26.56	44.09
Immersion heater rating	kW	3	3	3	3
Secondary return connection	No/Yes	No	Yes	Yes	Yes

*Heat Up Time, HWA Heat Pump Test 002:2020 (flow rate 0.42l/s and flow temperature of 55°C).

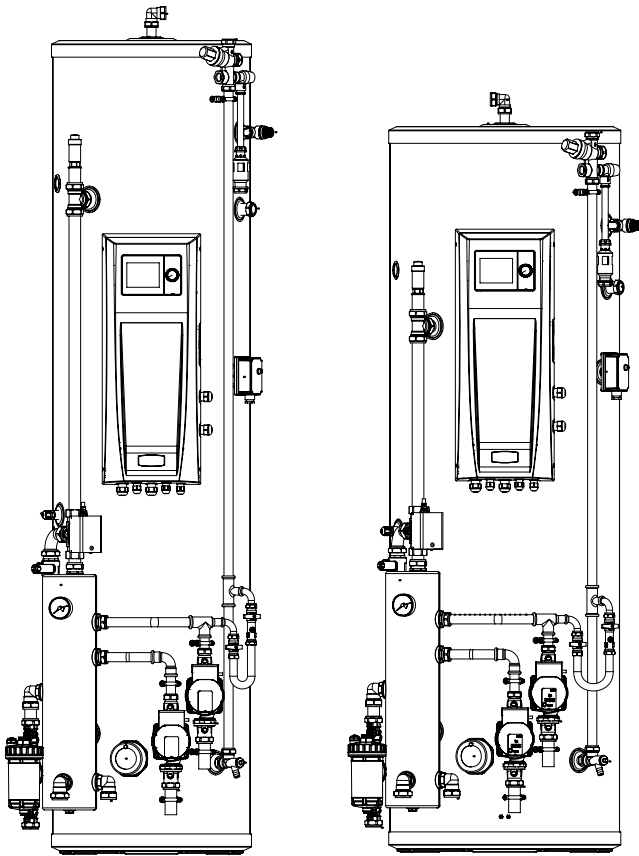

INCLUDES

- ✓ Control Box
- ✓ Buffer Tank
- ✓ Heat Pump Filter
- ✓ DHW 3-port Valve
- ✓ P&T Valve
- ✓ High Temp Cut Out
- ✓ Expansion Vessel
- ✓ Pressure Gauge
- ✓ Automatic Air Vent(s)
- ✓ Isolation Valves
- ✓ 3kW Immersion
- ✓ Circulation Pump(s)
- ✓ Flow & Return Thermistors
- ✓ DHW Thermistor
- ✓ Outdoor Sensor



Customer Service:

01482 498660

Technical Help:

01482 498663

Ideal Boilers, PO Box 103, National Avenue,
Kingston upon Hull, East Yorkshire, HU5 4JN

E: enquiries@idealboilers.com

idealheating.com |     