

# User Manual

## **HV Junction box**

In order to prevent improper operation before use, please carefully read this manual.

# Table of Contents

1. Introduction .....	1
2. Symbols .....	1
3. Safety .....	1
3.1 Handling .....	1
3.2 Installation .....	2
4. Product Information .....	2
5. Product Features .....	3
5.1 Overview .....	3
5.2 Dimensions .....	4
6. Installation .....	4
6.1 Packing List .....	4
6.2 Tools .....	5
6.3 Preparation .....	5
6.4 Installation Steps .....	5
6.5 Wiring Steps .....	6
7. Exclusion .....	8
8. Maintenance .....	8
8.1 Maintenance .....	8

# 1. Introduction







The document describes the installation, maintenance of the following junction box listed below.

- HV-junction box-50

This manual is designed for qualified personnel only. The tasks described in this document should be performed by authorized and qualified technicians only.

After Installation the Installer must explain the user manual to the end user.

## 2. Symbols

	Symbol Explanation CE mark. The product complies with the requirements of the applicable CE guidelines.
	Danger of high voltages. Danger to life due to high voltages in the inverter!
	Danger. Risk of electric shock!
	Install the product out of reach of children.
	Read the instruction manual before starting installation and operation.
	Do not dispose of the product with household wastes.
	PE conductor terminal.

## 3. Safety

Any work on the product should be handled by authorized technicians and hence it is understood that the technicians should familiarize themselves with the contents of this manual before any maintenance or installation is carried out on the system.

### 3.1 Handling

- Do not expose the product to open flame.
- Do not place the product under direct sunlight.
- Do not place the product near flammable materials.
- Store in a cool and dry place with ample ventilation.
- Do not store the product near water sources.
- Store the product on a flat surface.
- Store the product out of reach of children and animals.
- Do not damage the unit by dropping, deforming, impacting, cutting or penetrating with a sharp object.
- Always handle the junction box wearing the insulated gloves.
- Do not step on the product or place any foreign objects on it. This can result in damage.

- Do not store the product near water sources.

### 3.2 Installation

- After unpacking, please check the product for damages and missing parts.
- Make sure that the inverter and battery is completely turned off before commencing installation.
- Do not interchange the positive and negative terminals of the junction box.
- Ensure that there is no short circuit of the terminals or with any external device.
- Do not connect different battery types together.
- Do not open the product to repair or disassemble. Only manufacturer is allowed to carry out any such repairs.
- Do not install the product near water sources or places where the product can get wet.
- Install the product away from children or pets.
- Avoid electromagnetic interference that can compromise the correct operation of electronic equipment.
- The slope of the wall should be within  $\pm 5^\circ$ .

## 4. Product Information

Specifications	
Maximum number of parallel batteries	4
Rated voltage (Vdc)	500
Maximum continuous current (A)	50
Peak current (60s) (A)	65
Humidity (%)	5~95 (No Condensing)
Storage temperature (°C)	-20~+55
Operating temperature range (°C)	-20~+70
Ingress protection	IP65
Weight (kg)	2.2
Dimensions (WxHxD) (mm)	223*246*89
Altitude (m)	≤2000
Cooling method	Natural Cooling
Installation location	Indoor, Outdoor
Installation method	Wall-mounted

# 5. Product Features

## 5.1 Overview

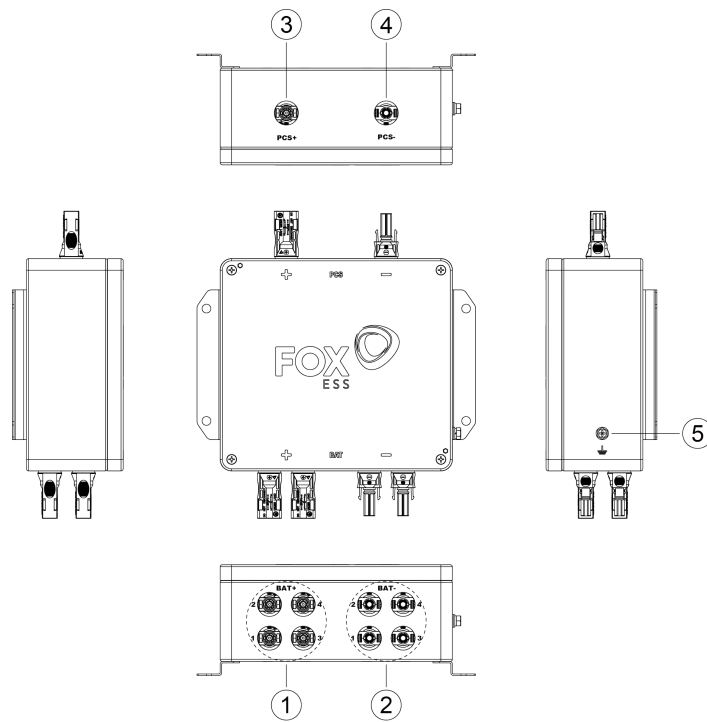

Item	Description
1	BAT+
2	BAT-
3	PCS+
4	PCS-
5	Ground Terminal

### **BAT+**

Cable entry for connecting positive power cables from battery towers.

### **BAT-**

Cable entry for connecting negative power cables from battery towers.

### **PCS+**

Output the DC cable gland to the battery positive interface of the inverter.

### **PCS-**

Output the DC cable gland to the battery negative interface of the inverter.

### **Ground Terminal**

Grounding cable output gland to a common ground point.

## 5.2 Dimensions

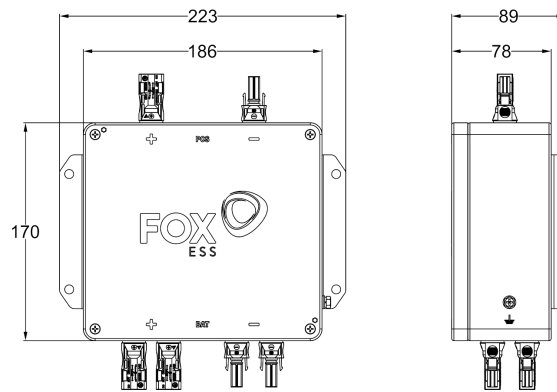

## 6. Installation

### 6.1 Packing List

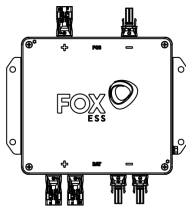

Box×1(A1)

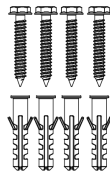

D8 Plastic Expansion  
Tube×4(B1)

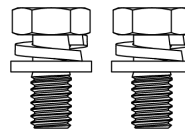

M5\*10 Screws×2(C1)



Ground Cable  
(1.2m)×1(D1)



Power Cable  
(1.2m)×1(E1)



Quick Installation  
Guide×1(F1)

## 6.2 Tools

The following tools will be required to install the battery.



6mm Magnetic  
Phillips Screwdriver(A2)



Crimpers(B2)



Safety Gloves(C2)



Safety  
Glasses(D2)



Rubber Mallet(E2)



Marker(F2)



Hammer Drill  
@φ8mm(G2)



Spirit Level(H2)

## 6.3 Preparation

- Please avoid direct sunlight, rain exposure and snow build-up during installation and operation.
- To avoid overheating, always make sure the air flow around the box is not blocked.
- Do not install in places where gas or flammable substances may be present.
- Avoid electromagnetic interference that can compromise the correct operation of electronic equipment.
- The slope of the wall should be within  $\pm 5^\circ$ .
- Reserve more than 300mm of space around the junction box.

## 6.4 Installation Steps

Step 1: Choose the place you want to install the junction box. Place the junction box on the wall and mark the position of the 4 holes from fixing blocks.

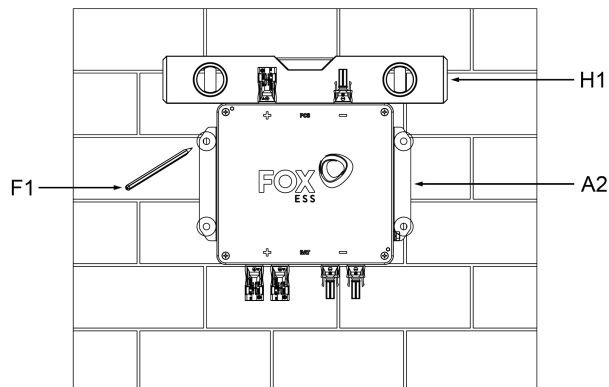

Step 2: Drill holes with hammer drill, make sure the holes are at least 45mm deep, and then tighten the expansion tubes.

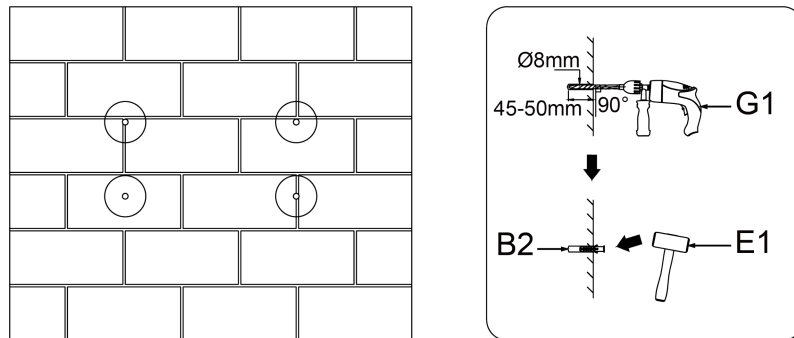

Step 3: Insert expansion tubes into the holes and tighten them. Install the fixing blocks with expansion screws.

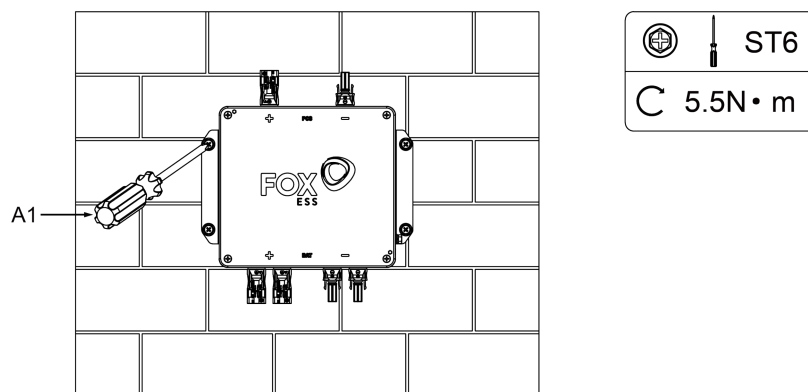

### 6.5 Wiring Steps

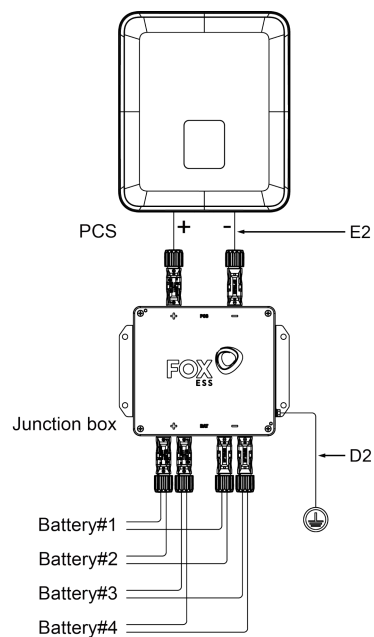

Note: Power cable must be pulled straight from the box for more than 80mm before bending.



Step 1: Connect the cable(D2) from the junction box to the ground.

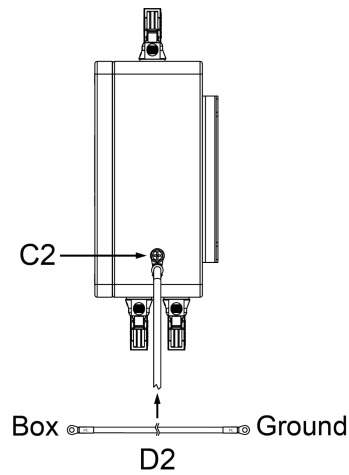

Step 2: Connect the power cable(included in the battery package list) from the battery to the junction box.

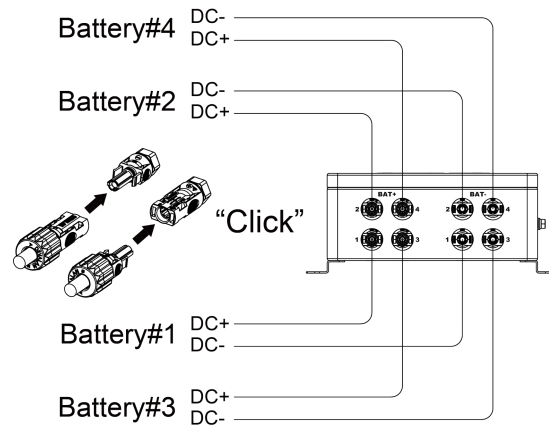

Step 3: Connect the power cable(E2) from the junction box to PCS.

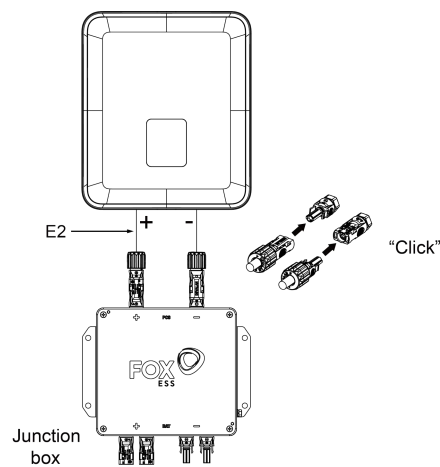

## 7. Exclusion

The warranty shall not cover the defects caused by normal wear and tear, inadequate maintenance, handling, storage faulty repair, modifications to the product by a third party other than manufacturer or manufacturer agent, failure to observe the product specification provided herein or improper use or installation, including but not limited to the following.

- Damage during transport or storage.
- Incorrect installation or maintenance of the product.
- Use the product in inappropriate environment.
- Insufficient ventilation.
- Ignoring applicable safety warnings and instructions.
- Altering or attempted repairs by unauthorized personnel.
- In case of force majeure (ex: lightning, storm, flood, fire, earthquake, etc.).
- There are no warranties-implied or express-other than those stipulated herein. manufacturer shall not be liable for any consequential or indirect damages arising or in connection with the product specification.

## 8. Maintenance

### 8.1 Maintenance

1) It is recommended to periodically inspect the panel and check the following points:

- There are no evident signs of rust or corrosion which may impair functioning and safety.
- There are no water infiltrations and excessive dust infiltration.
- The mass grounding and drains are efficient.
- All the DC connections are correctly tightened.
- There are no burn marks on the terminals.

2) If damaged components need to be replaced only use materials identical to those originally supplied.

3) If the electrical connections are damaged due to mechanical or electrical causes or due to rodents, immediately disconnect the system or at least the damaged part. After verifying that no failures were caused to the equipment, proceed with the replacement of the wires using similar materials.

