



Test report No:
2350552R-PV-CE-P01V01

TEST REPORT

Electromagnetic Compatibility (EMC)

Identification of item tested	Storage Inverter
Trademark	
Model and /or type reference	See models list
Features	N/A
Derived model(s)	N/A
Applicant's name / address	FOXESS Co., Ltd. No.939, Jinhai Third Road, New Airport Industry Area, Longwan District, Wenzhou, Zhejiang, China
Test method requested, standard	EN IEC 61000-6-1:2019 EN IEC 61000-6-2:2019 EN IEC 61000-6-3:2021 EN IEC 61000-6-4:2019
Verdict Summary	IN COMPLIANCE
Tested by (name / position & signature)	Hui Yu/Project Engineer 
Approved by (name / position & signature)	Oscar Shi/Manager 
Date of issue	May. 30, 2023
Report template No	Template_EN IEC 61000-6-1-2-3-4-EMC-V1.1

INDEX

	page
Competences and Guarantees.....	4
General conditions.....	4
Uncertainty.....	4
Environmental conditions.....	4
Possible test case verdicts	5
Definition of symbols used in this test report.....	5
Abbreviations	5
Document History	6
Remarks and Comments	6
1 General Information.....	7
1.1 General Description of the Item(s).....	7
1.2 The environment(s) in which the EUT is intended to be used	10
1.3 Test date	10
2 Description of Test Setup	11
2.1 Operating mode(s) used for tests.....	11
2.2 Port(s) of the EUT	11
2.3 Support / Auxiliary equipment / unit / software for the EUT	11
2.4 Test Configuration / Block diagram used for tests	12
3 Verdict summary section	14
3.1 Standards	14
3.2 Deviation(s) from the Standard(s) / Test Specification(s).....	14
3.3 Overview of results.....	15
3.4 Test Matrix.....	16
4 Emission Test Results	17
4.1 Conducted disturbance voltage – AC mains port(s)	17
4.2 Conducted disturbance voltage – DC power port(s).....	30
4.3 Conducted disturbance voltage – Telecommunications network port	37
4.4 Radiated electromagnetic disturbances (30 – 1000 MHz).....	39
4.5 Radiated electromagnetic disturbances (Above 1 GHz).....	46
4.6 Discontinuous disturbance (Clicks) on AC power leads	48
4.7 Harmonic current emissions.....	49

4.8	Voltage changes, voltage fluctuations and flicker	62
5	Immunity Test Results	69
5.1	Performance (Compliance) criteria	69
5.1.1	Performance criteria related to immunity tests	69
5.1.2	Manufacturer defined performance criteria	69
5.2	Monitored – Checked Functions / Parameters	70
5.3	Electrostatic discharge immunity	71
5.4	Radio-frequency electromagnetic fields immunity	72
5.5	Electrical Fast Transients immunity	73
5.6	Surge transient immunity	74
5.7	Injected currents (RF common mode) immunity	75
5.8	Power frequency magnetic field immunity	76
5.9	Power supply interruptions and dips immunity	77
6	Identification of the Equipment Under Test	78
7	Annex 1 - Measurement Uncertainties	80
8	Annex 2 - Test Photos	81
9	Annex 3 - EUT Photos	87

COMPETENCES AND GUARANTEES

DEKRA is a testing laboratory competent to carry out the tests described in this report.

In order to assure the traceability to other national and international laboratories, DEKRA has a calibration and maintenance program for its measurement equipment.

DEKRA guarantees the reliability of the data presented in this report, which is the result of the measurements and the tests performed to the item under test on the date and under the conditions stated in the report and it is based on the knowledge and technical facilities available at DEKRA at the time of performance of the test.

DEKRA is liable to the client for the maintenance of the confidentiality of all information related to the item under test and the results of the test.

The results presented in this Test Report apply only to the particular item under test established in this document.

IMPORTANT: No parts of this report may be reproduced or quoted out of context, in any form or by any means, except in full, without the previous written permission of DEKRA.

GENERAL CONDITIONS

1. This report is only referred to the item that has undergone the test.
2. This report does not constitute or imply on its own an approval of the product by the Certification Bodies or Competent Authorities.
3. This document is only valid if complete; no partial reproduction can be made without previous written permission of DEKRA.
4. This test report cannot be used partially or in full for publicity and/or promotional purposes without previous written permission of DEKRA.

UNCERTAINTY

For all measurements where guidance for the calculation of the instrumentation uncertainty of a measurement is specified in EN 55016-4-2 (CISPR 16-4-2), EN/IEC 61000-4 series or a product standard, the measurement instrumentation uncertainty has been calculated and applied in accordance with these standards.

Uncertainties have been calculated according to the DEKRA internal document PROD-P-EMC-M22. The reported expanded uncertainties are based on a standard uncertainty multiplied by a coverage factor of $k=2$, providing a level of confidence of approximately 95%. Refer to the Annex 1 for further information.

ENVIRONMENTAL CONDITIONS

The climatic conditions during the tests are within the limits specified by the manufacturer for the operation of the EUT and the test equipment. The climatic conditions during the tests were within the following limits:

Ambient temperature	15 °C – 35 °C
Relative Humidity air	25 % - 75 %; 30 % - 60 % (ESD)
Atmospheric pressure	86 kPa – 106 kPa

If explicitly required in the basic standard or applied product / product family standard the climatic values are recorded and documented separately in this test report.

POSSIBLE TEST CASE VERDICTS

Test case does not apply to test object	N/A
Test object does meet requirement	P (Pass) / PASS
Test object does not meet requirement	F (Fail) / FAIL
Not measured	N/M

DEFINITION OF SYMBOLS USED IN THIS TEST REPORT

<input checked="" type="checkbox"/> Indicates that the listed condition, standard or equipment is applicable for this report/test/EUT.			
<input type="checkbox"/> Indicates that the listed condition, standard or equipment is not applicable for this report/test/EUT.			
Decimal separator used in this report	<input checked="" type="checkbox"/>	Comma (,)	<input type="checkbox"/> Point (.)

ABBREVIATIONS

For the purposes of the present document, the following abbreviations apply:

EUT	:	Equipment Under Test
QP	:	Quasi-Peak
CAV	:	CISPR Average
AV	:	Average
CDN	:	Coupling Decoupling Network
SAC	:	Semi-Anechoic Chamber
OATS	:	Open Area Test Site
BW	:	Bandwidth
AM	:	Amplitude Modulation
PM	:	Pulse Modulation
HCP	:	Horizontal Coupling Plane
VCP	:	Vertical Coupling Plane
U_N	:	Nominal voltage
Tx	:	Transmitter
Rx	:	Receiver
N/A	:	Not Applicable
N/M	:	Not Measured

DOCUMENT HISTORY

Report nr.	Date	Description
2350552R-PV-CE-P01V01	May. 30, 2023	First release.
/	/	/

REMARKS AND COMMENTS

1. The equipment under test (EUT) does meet the essential requirements of the stated standard(s)/test(s).
2. The test results presented in this report relate only to the object tested.
3. This report will not be used for social proof function in China market.
4. The measurement result is considered in conformance with the requirement if it is within the prescribed limit, it is not necessary to account the uncertainty associated with the measurement result.

1 GENERAL INFORMATION

1.1 General Description of the Item(s)

Description of the item	Storage Inverter
Model / Type number	See models list
Serial number	N/A
Trademark	
Manufacturer	FOXESS Co., Ltd.
Address.....	No.939, Jinhai Third Road, New Airport Industry Area, Longwan District, Wenzhou, Zhejiang, China

Note 1: The EUT information is from customer declaration.

Note 2: This report selects the lowest emission limit and the highest immunity test levels.

Note 3: This report is based on report No. 21B0806R-PV-CE-P01V01, update the models list (added a new model: H3-10.0-E1). By the technology evaluation, no additional EMC testing is required.

Note 4: The test data is quoted from the previous report (Report No. 21B0806R-PV-CE-P01V01).

According to the declaration from applicant, these models same family, technical similar, except for rated output power, max output power and current, please see as in table below:

Models list:

Model	H3-5.0-E	H3-6.0-E	H3-8.0-E	H3-10.0-E	H3-10.0-E1	H3-12.0-E
Item						
PV Input						
Max. Recommended DC Power [W]	7500	9000	10400	13000	13000	15000
Max.DC voltage [V]	1000					
Norminal DC operating voltage [V]	720					
Max. input current (input A/input B) [A]	14A/14A	14A/14A	26A/14A	26A/14A	26A/14A	26A/14A
Max.short circuit current [A]	16A/16A	16A/16A	32A/16A	32A/16A	32A/16A	32A/16A
MPPT voltage range [V]	160~950					
MPPT voltage range [V] (fall load)	210-800	250-800	240-800	280-800	280-800	320-800
Start-up voltage [V]	160					
No. of MPP trackers	2					
Strings per MPP tracker	1+1	1+1	2+1	2+1	2+1	2+1
Model	H3-5.0-E	H3-6.0-E	H3-8.0-E	H3-10.0-E	H3-10.0-E1	H3-12.0-E
Item	AC3-5.0-E	AC3-6.0-E	AC3-8.0-E	AC3-10.0-E		AC3-12.0-E
AC Output						

Norminal AC power [VA]	5000	6000	8000	10000	10000	12000
Max. apparent AC power [VA]	5500	6600	8800	11000	10000	13200
Rated grid voltage (AC voltage range) [V]	400V/230 VAC, 380V/220 VAC,3L/N/PE					
Rated grid Frequency [Hz]	50/60Hz, ±5Hz					
Max. AC current[A] (Per phase)	8.0	9.6	12.8	16.0	16.0	19.2
THDi,Rated Power(%)	<3					
Power Factor	1 (Adjustable from 0.8 leading to 0.8 lagging)					
AC inrush current [A]	15A@0.5 ms					
MAX. output overcurrent protection Per phase [A]	45					
THDI	<3%@rated power					
AC Input						
Max. AC power [VA]	10000	12000	16000	16000	16000	16000
Rated grid voltage (AC voltage range) [V]	400V/230 VAC, 380V/220 VAC,3L/N/PE					
Rated grid Frequency [Hz]	50/60Hz, ±5Hz					
Max. AC current [A] (Per phase)	15.2	18.2	24.2	24.2	24.2	24.2
AC inrush current [A]	15A@0.5ms					
Power Factor	1(Adjustable from 0.8 leading to 0.8 lagging)					
EPS Output						
Max apparent AC power [VA]	5000	6000	8000	10000	10000	12000
Rated output voltage [V]	400V/230VAC;380V/220VAC,3L/N/PE					
Rated grid Frequency [Hz]	50/60					
EPS Max current [A] (Per phase)	15.2	18.2	21.2	22.7	22.7	22.7
Switch time	<20ms					
THDV	<3%@rated power					
Battery						
Battery Type	Lithium battery					
Battery voltage [V]	180-600					
Full AC load Battery voltage [V]	205	250	330	410	410	480

Max. Charge/ discharge current [A]	26
---------------------------------------	----

Remark: The above models are the same in electrical characteristics. The H3-12.0-E model was selected for the full tests and the H3-5.0-E model is additionally tested for Harmonic current emissions and Voltage changes, voltage fluctuations and flicker. The corresponding data is representative for other models as well.

Rated power supply	Voltage and Frequency		Reference poles				
			L1	L2	L3	N	PE
<input checked="" type="checkbox"/>	AC port: 400/230 Vac, 380/220 Vac, 50/60 Hz		<input checked="" type="checkbox"/>	<input checked="" type="checkbox"/>	<input checked="" type="checkbox"/>	<input checked="" type="checkbox"/>	<input checked="" type="checkbox"/>
<input type="checkbox"/>			<input type="checkbox"/>	<input type="checkbox"/>	<input type="checkbox"/>	<input type="checkbox"/>	<input type="checkbox"/>
<input checked="" type="checkbox"/>	PV port: 160-1000 Vdc						
<input checked="" type="checkbox"/>	Battery: 180-600 Vdc						
Rated Power	N/A						
Clock frequencies	< 108 MHz						
Other parameters	N/A						
Software version	V1.14						
Hardware version	V1.4						
Nominal cabinet dimensions in cm (W x D x H)	44.9 x 19.8 x 51.9						
Mounting position	<input checked="" type="checkbox"/>	Table top equipment					
	<input checked="" type="checkbox"/>	Wall/Ceiling mounted equipment					
	<input type="checkbox"/>	Floor standing equipment					
	<input type="checkbox"/>	Hand-held equipment					

Intended use of the Equipment Under Test (EUT)
EUT is a three-phase storage inverter that converts the DC power generated by PV strings into AC power and feeds the power into the power grid. For the further information, refer to the user's manual.



No	Module/parts of test item	Type	Manufacturer
---	---	---	---
No	Documents as provided by the applicant - Description	File name	Issue date
---	---	---	---
Modifications to the test item during testing	<input checked="" type="checkbox"/>	N/A	<input type="checkbox"/> <u>Supplemental information:</u>

Copy of marking plate:



FOX
ESS

H3-12.0-E
Storage Inverter
www.fox-ess.com

P V INPUT	Max. input power	15000W
	Absolute max. voltage	1000Vdc
	MPPT voltage range	160-950Vdc
	Nominal operating voltage	720Vdc
	Max. input current	26A/14A
	Isc PV	32A/16A
BATTERY INPUT	Battery voltage range	180-600Vdc
	Max. charge/discharge current	26A/26A
	Battery type	Lithium-Ion
A C INPUT	Nominal voltage	220/380, 230/400Vac
	Nominal frequency	50/60Hz
	Max. input current	24.2A
	Max. apparent power	16000VA
	Power factor	1(±0.8 adjustable)
A C OUTPUT	Nominal voltage	220/380, 230/400Vac
	Nominal frequency	50/60Hz
	Max. power	12000W
	Max. apparent power	13200VA
	Max. output current	19.2A
EPS OUTPUT	Nominal voltage	220/380, 230/400Vac
	Max. output current	22.7A
	Nominal frequency	50/60Hz
	Max. apparent power	15000VA
Ingress protection		IP65
Operation temperature range		-25...+60°C
Protective class		Class I
Inverter topology		Non-isolated
Over Voltage Category		III(AC), II(DC)
DRM0 <input checked="" type="checkbox"/> DRM1 <input type="checkbox"/> DRM2 <input type="checkbox"/> DRM3 <input type="checkbox"/> DRM4 <input type="checkbox"/> DRM5 <input type="checkbox"/> DRM6 <input type="checkbox"/> DRM7 <input type="checkbox"/> DRM8 <input type="checkbox"/>		
		
EN 50549-1 G99 AS 4777.2 IEC 62109-1/2 IEC 61000-6-2/3 FOXESS CO., LTD. No.939, Jinhai Third Road, New Airport Industry Area, Longwan District, Wenzhou, Zhejiang, China 10-200-20410-03 Made in China		
		

1.2 The environment(s) in which the EUT is intended to be used

The equipment under test (EUT) is intended to be used in the following environment(s):

<input checked="" type="checkbox"/>	Residential (domestic) environment.
<input checked="" type="checkbox"/>	Commercial and light-industrial environment.
<input checked="" type="checkbox"/>	Industrial environment.

1.3 Test date

Test Location	No. 99, Hongye Road, Suzhou Industrial Park Suzhou, 215006, P.R. China
Date (receive sample)	Jan. 22, 2022
Date (start)	Jan. 22, 2022
Date (finish)	May. 30, 2022

2 DESCRIPTION OF TEST SETUP

2.1 Operating mode(s) used for tests

During the tests the following operating mode(s) has(have) been used.

Operating mode	Operating mode description	Used for testing	
		Emission	Immunity
1	PV + Battery Grid-tied Mode	<input checked="" type="checkbox"/>	<input type="checkbox"/>
2	PV + Grid Charger Mode	<input checked="" type="checkbox"/>	<input type="checkbox"/>
3	PV + Battery Discharge Mode	<input checked="" type="checkbox"/>	<input type="checkbox"/>
4	PV Mode- H3-12.0-E	<input checked="" type="checkbox"/>	<input checked="" type="checkbox"/>
5	PV Mode- H3-5.0-E	<input checked="" type="checkbox"/>	<input type="checkbox"/>

Supplemental information:
 The H3-12.0-E model was selected for the full tests and the H3-5.0-E model is additionally tested for Harmonic current emissions and Voltage changes, voltage fluctuations and flicker.

2.2 Port(s) of the EUT

Port name and description	Connected to / Termination	Cable		
		Length used during test [m]	Attached during test	Shielded
PV port	DC Source	1,5	<input checked="" type="checkbox"/>	<input type="checkbox"/>
Grid port	LV power grid	1.5	<input checked="" type="checkbox"/>	<input type="checkbox"/>
EPS port	Resistive Load	1,5	<input checked="" type="checkbox"/>	<input type="checkbox"/>
Battery port	DC Source	1.5	<input checked="" type="checkbox"/>	<input type="checkbox"/>

Supplemental information:

2.3 Support / Auxiliary equipment / unit / software for the EUT

The EUT has been tested with the following auxiliary equipment / unit / software:

Auxiliary equipment / unit / software	Type / Version	Manufacturer	Supplied by
DC Source	IT6018C-1500-40	ITECH	Applicant
DC Source	62150H-1000S	Chroma	Applicant
Resistive Load	N/A	Cpower	Applicant

Supplemental information:

2.4 Test Configuration / Block diagram used for tests

The following test setup / configuration / block diagram has been used during the tests:

Test Item		EMI (Mode 1, 2, 3)			
Product		Manufacturer	Model No.	Serial No.	Power Cord
1	DC Source	ITECH	ITECH-1500-40	N/A	Non-Shielded, 2,0 m
2	DC Source	Chroma	62150H-1000S	N/A	Non-Shielded, 2,0 m
3	Resistive Load	Cpower	N/A	N/A	Non-Shielded, 1,5 m

Test Configuration / Block diagram

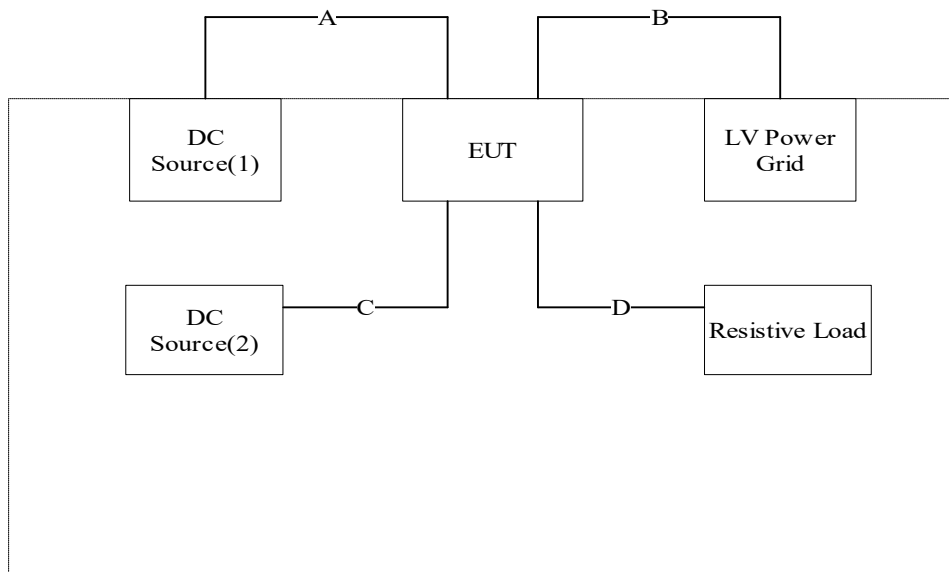

Cable Type		Cable Description
A	Power line	Non-Shielded, 1,5 m
B	Power line	Non-Shielded, 1,5 m
C	Power line	Non-Shielded, 1,5 m
D	Power line	Non-Shielded, 1,5 m

Test Item		EMI / EMS (Mode 4, 5)			
Product		Manufacturer	Model No.	Serial No.	Power Cord
1	DC Source	ITECH	ITECH-1500-40	N/A	Non-Shielded, 2,0 m

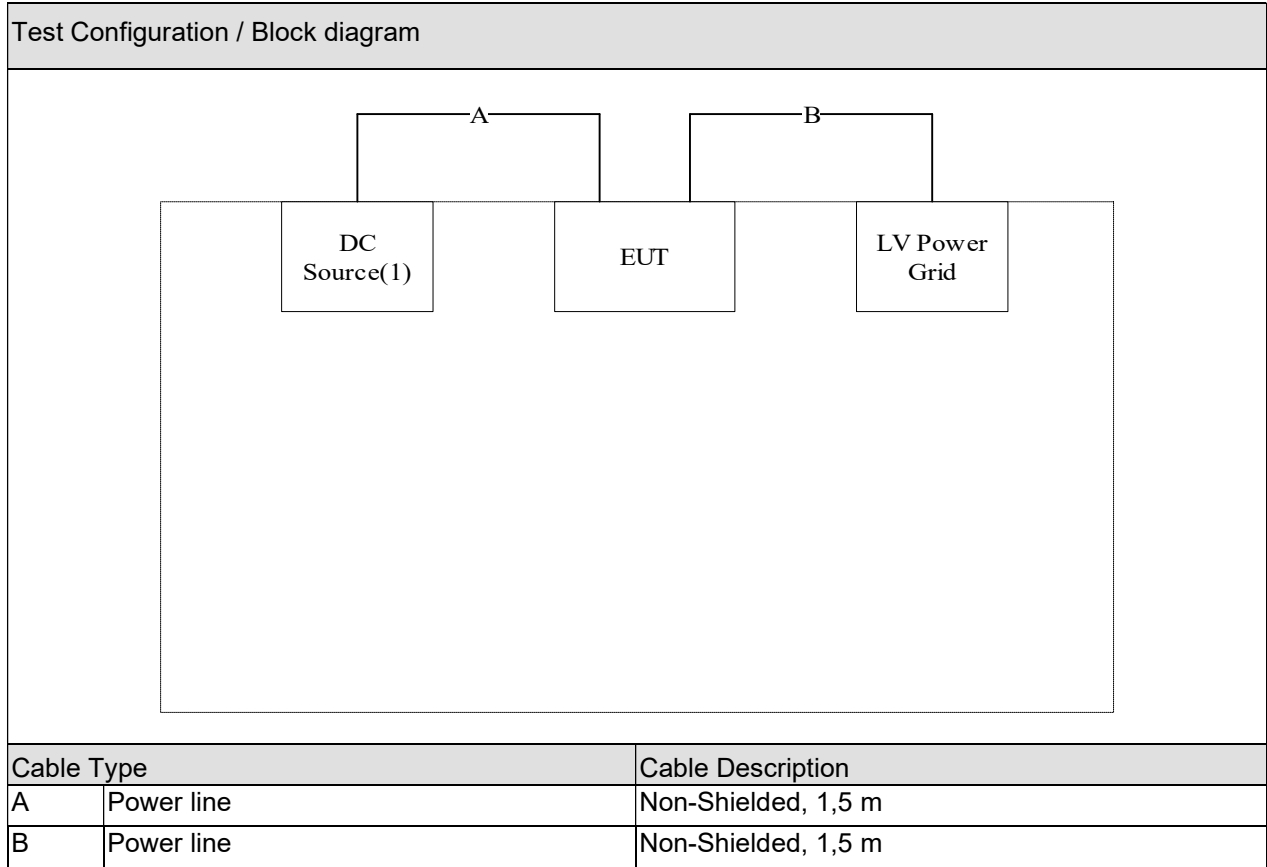

3 VERDICT SUMMARY SECTION

This chapter presents an overview of standards and results. Refer to the next chapters for details of measured test results and applied test levels.

3.1 Standards

Standard	Year	Description
EN IEC 61000-6-3	2021	Generic standards - Emission standard for equipment in residential environments
EN IEC 61000-6-4	2019	Generic standards - Emission standard for industrial environments
EN 55016-2-1 +A1	2014 2017	Methods of measurement of disturbances and immunity - Conducted disturbance measurements.
EN 55016-2-3	2017	Methods of measurement of disturbances and immunity - Radiated disturbance measurements.
EN 55032 +A11	2015 2020	Electromagnetic compatibility of multimedia equipment - Emission requirements
EN 55014-1 +A11	2017 2020	Requirements for household appliances, electric tools and similar apparatus – Part 1: Emission.
EN IEC 61000-3-2	2019	Limits for harmonic current emissions (equipment input current ≤ 16 A per phase).
EN 61000-3-3 +A1	2013 2019	Limitation of voltage changes, voltage fluctuations and flicker in public low-voltage supply systems, for equipment with rated current ≤ 16 A per phase and not subject to conditional connection.
EN 61000-3-12	2011	Limits for harmonic currents produced by equipment connected to public low-voltage systems with input current > 16 A and ≤ 75 A per phase.
EN IEC 61000-3-11	2019	Limitation of voltage changes, voltage fluctuations and flicker in public low-voltage supply systems - Equipment with rated current ≤ 75 A and subject to conditional connection.
EN IEC 61000-6-1	2019	Generic standards - Immunity standard for residential, commercial and light-industrial environments
EN IEC 61000-6-2	2019	Generic standards - Immunity for residential, commercial and light-industrial environments.
EN 61000-4-2	2009	Electrostatic discharge immunity test.
EN 61000-4-3 +A1 +A2	2006 2008 2010	Radiated, radio-frequency, electromagnetic field immunity test.
EN 61000-4-4	2012	Electrical fast transient/burst immunity test.
EN 61000-4-5	2014	Surge immunity test.
EN 61000-4-6	2014	Immunity to conducted disturbances, induced by radio-frequency fields.
EN 61000-4-8	2010	Power frequency magnetic field immunity test.
EN 61000-4-11	2004	Voltage dips, short interruptions and voltage variations immunity tests.

3.2 Deviation(s) from the Standard(s) / Test Specification(s)

No deviation.

3.3 Overview of results

EMISSION TESTS – EN IEC 61000-6-3			
Requirement – Test case	Basic standard(s)	Verdict	Remark
Conducted disturbance voltage at AC power port(s)	EN 55016-2-1	PASS	---
Conducted disturbance voltage at DC power port(s)	EN 55016-2-1	PASS	---
Conducted disturbance voltage at Telecommunications / network port(s)	EN 55032, EN 55016-2-1	N/A	See 1)
Radiated electromagnetic disturbances (30 MHz to 1000 MHz)	EN 55016-2-3	PASS	---
Radiated electromagnetic disturbances (Above 1 GHz)	EN 55016-2-3	N/A	See 2)
Discontinuous disturbance (Clicks)	EN 55014-1	N/A	See 3)
Harmonic current emissions	EN IEC 61000-3-2 EN 61000-3-12	PASS	---
Voltage changes, voltage fluctuations and flicker	EN 61000-3-3	PASS	---
Supplementary information:			
1) The wired network port of the EUT is only for internal software upgrade, not connected to the external network, so it needs not to perform the test item. 2) The highest internal frequency of the EUT is less than 108 MHz. 3) Exemptions from click measurements applicable (clause 4.2.3).			

IMMUNITY TESTS – EN IEC 61000-6-2			
Requirement – Test case	Basic standard(s)	Verdict	Remark
Electrostatic discharge	EN 61000-4-2	PASS	---
Radio-frequency electromagnetic fields	EN 61000-4-3	PASS	---
Fast transients	EN 61000-4-4	PASS	---
Surge transient	EN 61000-4-5	PASS	---
Injected currents (radio-frequency common mode)	EN 61000-4-6	PASS	---
Power frequency magnetic fields	EN 61000-4-8	PASS	---
Voltage dips and short interruptions	EN 61000-4-11	N/A	See 1&2)
Supplementary information:			
1) Applicable only to input ports. 2) Not applicable because no test requirements have been specified for DC/battery powered apparatus.			

3.4 Test Matrix

EMISSION TESTS	Mode		
	Mode 1, 2, 3	Mode 4, 5	/
Conducted disturbance voltage at AC power port(s) (150 KHz – 30 MHz)	<input checked="" type="checkbox"/>	<input type="checkbox"/>	<input type="checkbox"/>
Conducted disturbance voltage at DC power port(s) (150 KHz – 30 MHz)	<input checked="" type="checkbox"/>	<input type="checkbox"/>	<input type="checkbox"/>
Conducted disturbance voltage at telecommunications/ network port (150 KHz – 30 MHz)	<input type="checkbox"/>	<input type="checkbox"/>	<input type="checkbox"/>
Radiated electromagnetic disturbances (30 MHz to 1000 MHz)	<input checked="" type="checkbox"/>	<input type="checkbox"/>	<input type="checkbox"/>
Radiated electromagnetic disturbances (Above 1 GHz)	<input type="checkbox"/>	<input type="checkbox"/>	<input type="checkbox"/>
Discontinuous disturbance (Clicks)	<input type="checkbox"/>	<input type="checkbox"/>	<input type="checkbox"/>
Harmonic current emissions	<input type="checkbox"/>	<input checked="" type="checkbox"/>	<input type="checkbox"/>
Voltage changes, voltage fluctuations and flicker	<input type="checkbox"/>	<input checked="" type="checkbox"/>	<input type="checkbox"/>
<u>Supplementary Information:</u>			

IMMUNITY TESTS	Mode		
	Mode 4	Mode 1, 2, 3, 5	/
Electrostatic discharge	<input checked="" type="checkbox"/>	<input type="checkbox"/>	<input type="checkbox"/>
Radio-frequency electromagnetic fields	<input checked="" type="checkbox"/>	<input type="checkbox"/>	<input type="checkbox"/>
Fast transients	<input checked="" type="checkbox"/>	<input type="checkbox"/>	<input type="checkbox"/>
Surges	<input checked="" type="checkbox"/>	<input type="checkbox"/>	<input type="checkbox"/>
Injected currents (radio-frequency common mode)	<input checked="" type="checkbox"/>	<input type="checkbox"/>	<input type="checkbox"/>
Power frequency magnetic field immunity	<input checked="" type="checkbox"/>	<input type="checkbox"/>	<input type="checkbox"/>
Voltage dips and short interruptions	<input type="checkbox"/>	<input type="checkbox"/>	<input type="checkbox"/>
<u>Supplementary Information:</u>			

4 EMISSION TEST RESULTS

4.1 Conducted disturbance voltage – AC mains port(s)	VERDICT: PASS
---	----------------------

Standard	EN IEC 61000-6-3
Basic standard(s)	EN 55016-2-1

Limits

Frequency range [MHz]	Limit: QP [dB(μ V) ¹⁾]	Limit: AV [dB(μ V) ¹⁾]	IF BW	Detector(s)
0,15 – 0,50	66 – 56 ²⁾	56 – 46 ²⁾	9 KHz	QP, CAV
0,50 – 5,0	56	46	9 KHz	QP, CAV
5,0 – 30	60	50	9 KHz	QP, CAV

¹⁾ At the transition frequency, the lower limit applies.

²⁾ The limit decreases linearly with the logarithm of the frequency.

Performed measurements

Port under test	Terminal					
<input checked="" type="checkbox"/> AC port	<input checked="" type="checkbox"/> N	<input checked="" type="checkbox"/> L1	<input checked="" type="checkbox"/> L2	<input checked="" type="checkbox"/> L3		
<input type="checkbox"/> Other:	<input type="checkbox"/> N	<input type="checkbox"/> L1	<input type="checkbox"/> L2	<input type="checkbox"/> L3		
Voltage – Mains [V]	PV: 480 Vdc, Battery: 500 Vdc, AC mains: 400 Vac					
Frequency – Mains [Hz]	50 Hz					
Test method applied	<input checked="" type="checkbox"/> Artificial mains network					
	<input type="checkbox"/> Voltage probe					
Test setup	<input checked="" type="checkbox"/> Table top	<input type="checkbox"/> Artificial hand applied				
	<input type="checkbox"/> Floor standing	<input type="checkbox"/> Other:				
	Refer to the Annex 2 for test setup photo(s).					
Operating mode(s) used	Mode 1, 2, 3					
Remark	---					

See next page.

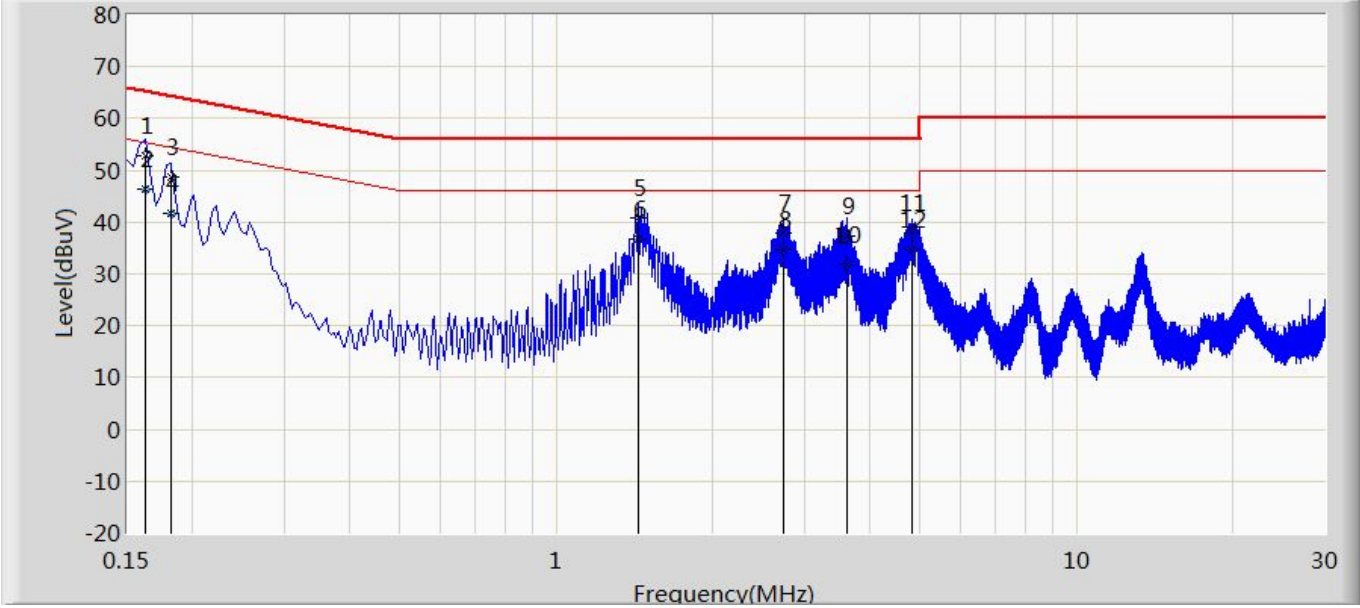
Measurement data		Port under test	AC mains port							
Operating mode / voltage		Mode 1/ PV: 480 Vdc, Battery: 500 Vdc, AC mains: 400 Vac								
Site: AC1		Time: 2022/05/30								
Limit: EN IEC 61000-6-3_AC Mains Port		Margin: 0								
Probe: NNLK 8129_(0.009-30MHz)		Polarity: Line1								
EUT: Storage Inverter		Power: PV: 480 Vdc, Battery: 500 Vdc, AC mains: 400 Vac								
Note: Mode 1										
										
No	Mark	Frequency (MHz)	Measure Level (dBuV)	Reading Level (dBuV)	Over Limit (dB)	Limit (dBuV)	Probe (dB)	Cable (dB)	Amp (dB)	Type
1		0.162	52.921	52.508	-12.440	65.361	0.388	0.025	0.000	QP
2	*	0.162	46.513	46.100	-8.847	55.361	0.388	0.025	0.000	AV
3		0.182	48.859	48.534	-15.535	64.394	0.300	0.026	0.000	QP
4		0.182	41.731	41.405	-12.663	54.394	0.300	0.026	0.000	AV
5		1.442	40.799	40.276	-15.201	56.000	0.453	0.071	0.000	QP
6		1.442	36.862	36.339	-9.138	46.000	0.453	0.071	0.000	AV
7		2.742	37.782	37.407	-18.218	56.000	0.270	0.105	0.000	QP
8		2.742	34.726	34.351	-11.274	46.000	0.270	0.105	0.000	AV
9		3.622	37.185	36.806	-18.815	56.000	0.259	0.121	0.000	QP
10		3.622	31.813	31.433	-14.187	46.000	0.259	0.121	0.000	AV
11		4.822	37.810	37.428	-18.190	56.000	0.243	0.139	0.000	QP
12		4.822	34.584	34.202	-11.416	46.000	0.243	0.139	0.000	AV
<p>Note:</p> <p>1. " * ", means this data is the worst emission level.</p> <p>2. Measurement Level = Reading Level + Factor(Probe+Cable-Amp).</p>										
Remark										

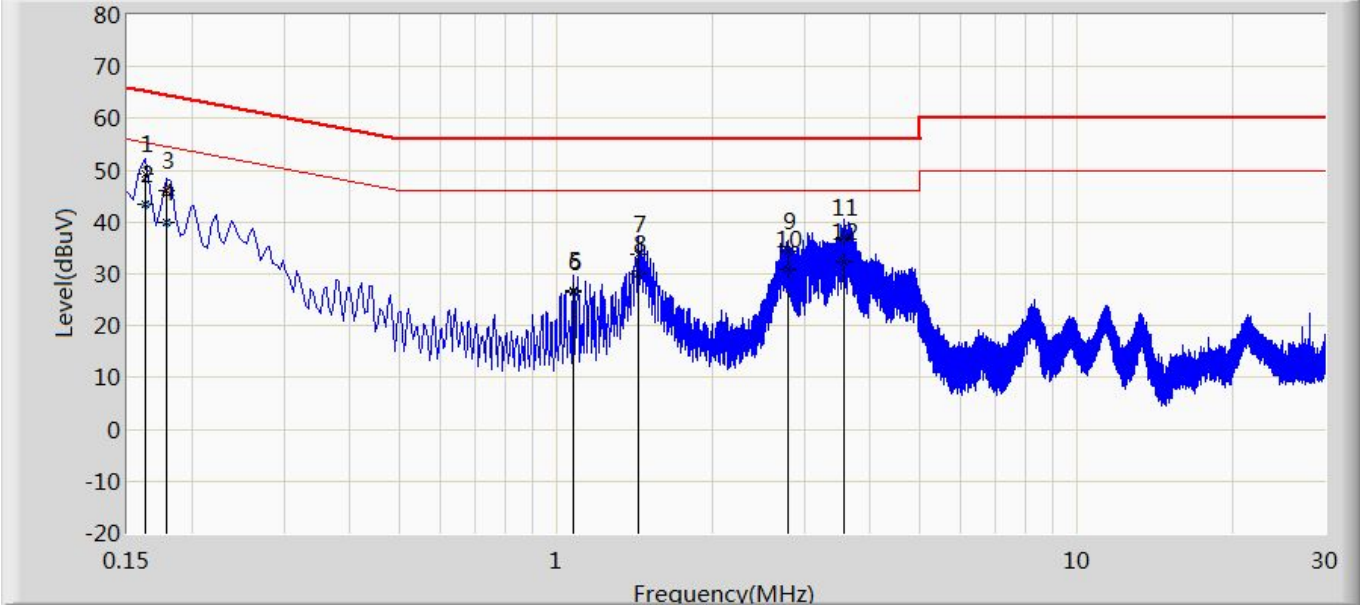
Measurement data		Port under test	AC mains port							
Operating mode / voltage		Mode 1/ PV: 480 Vdc, Battery: 500 Vdc, AC mains: 400 Vac								
Site: AC1		Time: 2022/05/30								
Limit: EN IEC 61000-6-3_AC Mains Port		Margin: 0								
Probe: NNLK 8129_(0.009-30MHz)		Polarity: Line2								
EUT: Storage Inverter		Power: PV: 480 Vdc, Battery: 500 Vdc, AC mains: 400 Vac								
Note: Mode 1										
										
No	Mark	Frequency (MHz)	Measure Level (dBuV)	Reading Level (dBuV)	Over Limit (dB)	Limit (dBuV)	Probe (dB)	Cable (dB)	Amp (dB)	Type
1		0.162	49.300	48.776	-16.061	65.361	0.498	0.025	0.000	QP
2	*	0.162	43.584	43.060	-11.777	55.361	0.498	0.025	0.000	AV
3		0.178	46.161	45.745	-18.418	64.578	0.389	0.026	0.000	QP
4		0.178	40.033	39.618	-14.545	54.578	0.389	0.026	0.000	AV
5		1.082	26.909	26.244	-29.091	56.000	0.605	0.060	0.000	QP
6		1.082	26.426	25.761	-19.574	46.000	0.605	0.060	0.000	AV
7		1.442	33.873	33.310	-22.127	56.000	0.493	0.071	0.000	QP
8		1.442	29.979	29.415	-16.021	46.000	0.493	0.071	0.000	AV
9		2.782	34.277	33.823	-21.723	56.000	0.348	0.106	0.000	QP
10		2.782	30.769	30.315	-15.231	46.000	0.348	0.106	0.000	AV
11		3.582	36.954	36.455	-19.046	56.000	0.378	0.121	0.000	QP
12		3.582	32.398	31.899	-13.602	46.000	0.378	0.121	0.000	AV
<p>Note:</p> <p>1. " * ", means this data is the worst emission level.</p> <p>2. Measurement Level = Reading Level + Factor(Probe+Cable-Amp).</p>										
Remark										

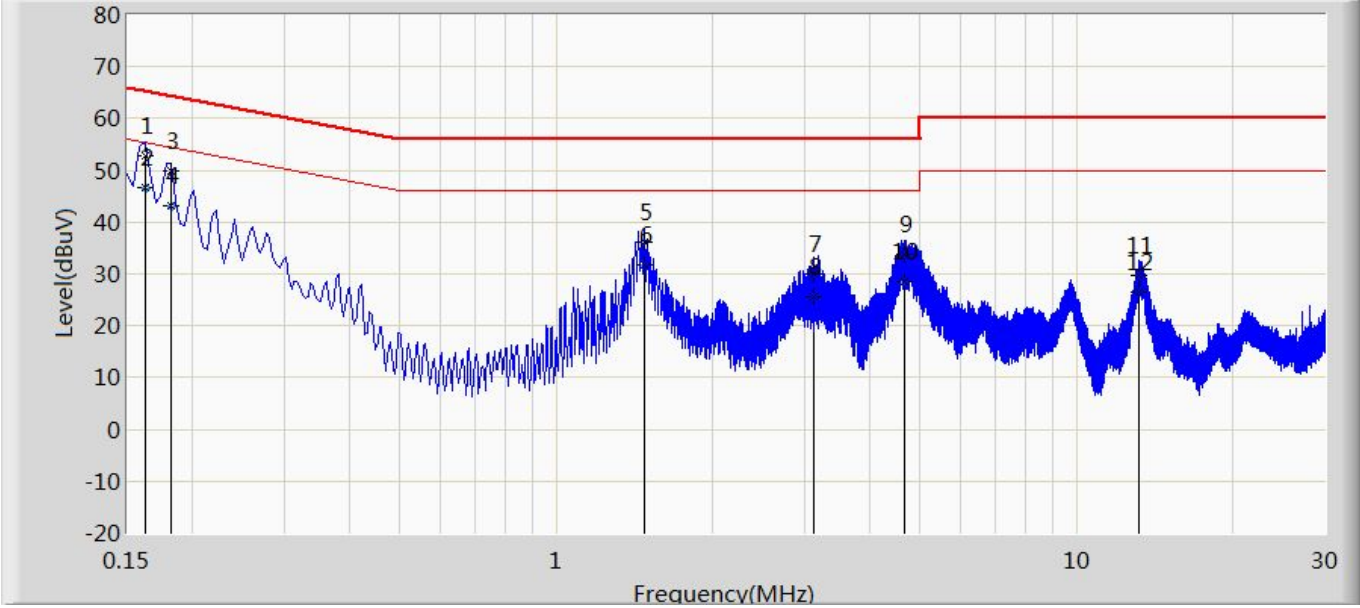
Measurement data		Port under test	AC mains port							
Operating mode / voltage		Mode 1/ PV: 480 Vdc, Battery: 500 Vdc, AC mains: 400 Vac								
Site: AC1		Time: 2022/05/30								
Limit: EN IEC 61000-6-3_AC Mains Port		Margin: 0								
Probe: NNLK 8129_(0.009-30MHz)		Polarity: Line3								
EUT: Storage Inverter		Power: PV: 480 Vdc, Battery: 500 Vdc, AC mains: 400 Vac								
Note: Mode 1										
										
No	Mark	Frequency (MHz)	Measure Level (dBuV)	Reading Level (dBuV)	Over Limit (dB)	Limit (dBuV)	Probe (dB)	Cable (dB)	Amp (dB)	Type
1		0.162	52.855	52.249	-12.506	65.361	0.581	0.025	0.000	QP
2	*	0.162	46.617	46.011	-8.744	55.361	0.581	0.025	0.000	AV
3		0.182	49.750	49.275	-14.644	64.394	0.449	0.026	0.000	QP
4		0.182	43.044	42.570	-11.349	54.394	0.449	0.026	0.000	AV
5		1.478	36.057	35.435	-19.943	56.000	0.550	0.072	0.000	QP
6		1.478	31.766	31.144	-14.234	46.000	0.550	0.072	0.000	AV
7		3.122	30.080	29.438	-25.920	56.000	0.530	0.111	0.000	QP
8		3.122	25.621	24.980	-20.379	46.000	0.530	0.111	0.000	AV
9		4.662	33.803	33.177	-22.197	56.000	0.489	0.138	0.000	QP
10		4.662	28.652	28.026	-17.348	46.000	0.489	0.138	0.000	AV
11		13.162	29.794	29.205	-30.206	60.000	0.359	0.230	0.000	QP
12		13.162	26.504	25.915	-23.496	50.000	0.359	0.230	0.000	AV
Note: 1. " * ", means this data is the worst emission level. 2. Measurement Level = Reading Level + Factor(Probe+Cable-Amp).										
Remark										

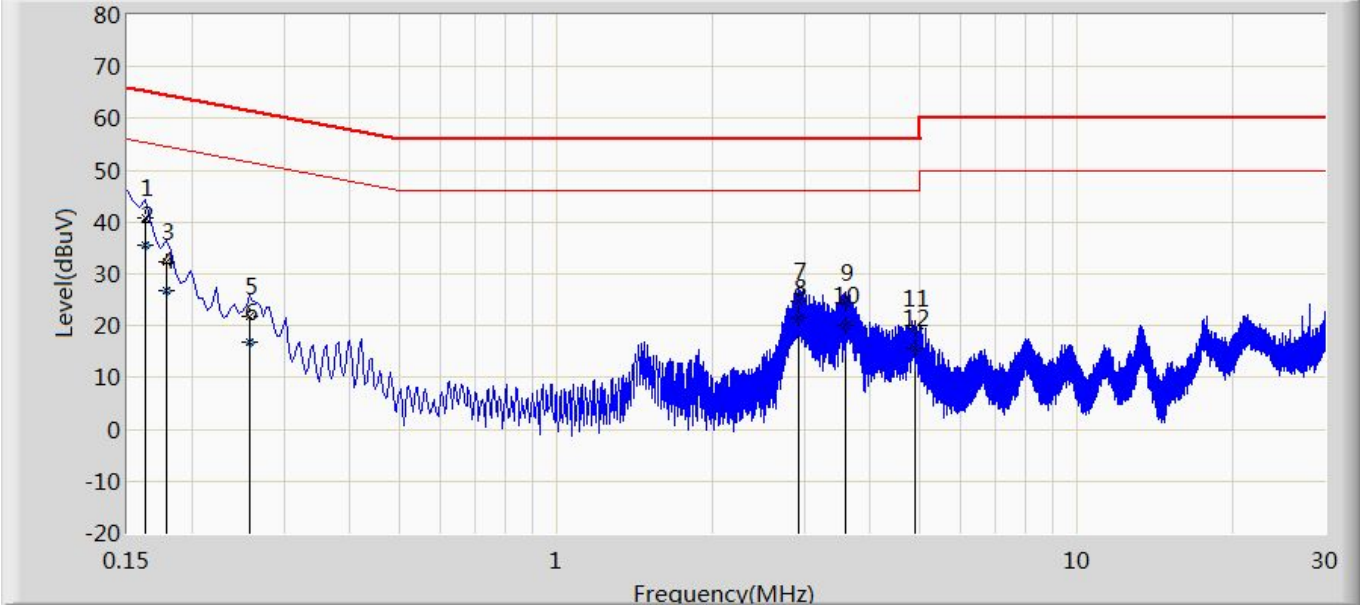
Measurement data		Port under test	AC mains port							
Operating mode / voltage		Mode 1/ PV: 480 Vdc, Battery: 500 Vdc, AC mains: 400 Vac								
Site: AC1		Time: 2022/05/30								
Limit: EN IEC 61000-6-3_AC Mains Port		Margin: 0								
Probe: NNLK 8129_(0.009-30MHz)		Polarity: Neutral								
EUT: Storage Inverter		Power: PV: 480 Vdc, Battery: 500 Vdc, AC mains: 400 Vac								
Note: Mode 1										
										
No	Mark	Frequency (MHz)	Measure Level (dBuV)	Reading Level (dBuV)	Over Limit (dB)	Limit (dBuV)	Probe (dB)	Cable (dB)	Amp (dB)	Type
1		0.162	40.741	40.041	-24.620	65.361	0.675	0.025	0.000	QP
2	*	0.162	35.617	34.917	-19.744	55.361	0.675	0.025	0.000	AV
3		0.178	32.277	31.810	-32.302	64.578	0.441	0.026	0.000	QP
4		0.178	26.859	26.392	-27.720	54.578	0.441	0.026	0.000	AV
5		0.258	21.913	21.697	-39.582	61.496	0.185	0.031	0.000	QP
6		0.258	16.816	16.599	-34.680	51.496	0.185	0.031	0.000	AV
7		2.918	24.814	24.190	-31.186	56.000	0.516	0.108	0.000	QP
8		2.918	21.433	20.809	-24.567	46.000	0.516	0.108	0.000	AV
9		3.602	24.533	23.915	-31.467	56.000	0.497	0.121	0.000	QP
10		3.602	20.148	19.530	-25.852	46.000	0.497	0.121	0.000	AV
11		4.902	19.407	18.802	-36.593	56.000	0.463	0.143	0.000	QP
12		4.902	15.536	14.930	-30.464	46.000	0.463	0.143	0.000	AV
<p>Note:</p> <p>1. " * ", means this data is the worst emission level.</p> <p>2. Measurement Level = Reading Level + Factor(Probe+Cable-Amp).</p>										
Remark										

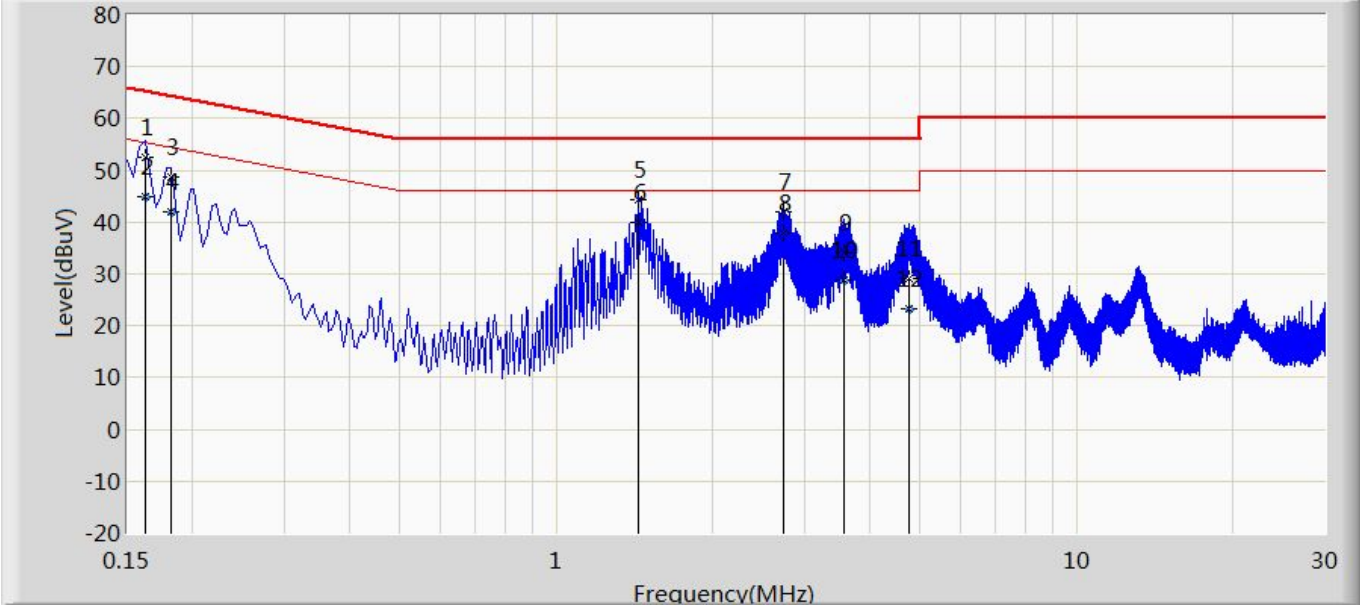
Measurement data		Port under test	AC mains port							
Operating mode / voltage		Mode 2/ PV: 480 Vdc, Battery: 500 Vdc, AC mains: 400 Vac								
Site: AC1		Time: 2022/05/30								
Limit: EN IEC 61000-6-3_AC Mains Port		Margin: 0								
Probe: NNLK 8129_(0.009-30MHz)		Polarity: Line1								
EUT: Storage Inverter		Power: PV: 480 Vdc, Battery: 500 Vdc, AC mains: 400 Vac								
Note: Mode 2										
										
No	Mark	Frequency (MHz)	Measure Level (dBuV)	Reading Level (dBuV)	Over Limit (dB)	Limit (dBuV)	Probe (dB)	Cable (dB)	Amp (dB)	Type
1		0.162	52.467	52.055	-12.893	65.361	0.388	0.025	0.000	QP
2		0.162	45.058	44.645	-10.303	55.361	0.388	0.025	0.000	AV
3		0.182	48.653	48.328	-15.740	64.394	0.300	0.026	0.000	QP
4		0.182	41.935	41.610	-12.458	54.394	0.300	0.026	0.000	AV
5		1.438	44.450	43.926	-11.550	56.000	0.454	0.071	0.000	QP
6	*	1.438	40.053	39.528	-5.947	46.000	0.454	0.071	0.000	AV
7		2.742	41.853	41.478	-14.147	56.000	0.270	0.105	0.000	QP
8		2.742	37.981	37.606	-8.019	46.000	0.270	0.105	0.000	AV
9		3.578	34.086	33.706	-21.914	56.000	0.259	0.121	0.000	QP
10		3.578	28.931	28.551	-17.069	46.000	0.259	0.121	0.000	AV
11		4.762	29.059	28.677	-26.941	56.000	0.243	0.139	0.000	QP
12		4.762	23.290	22.907	-22.710	46.000	0.243	0.139	0.000	AV
<p>Note:</p> <p>1. " * ", means this data is the worst emission level.</p> <p>2. Measurement Level = Reading Level + Factor(Probe+Cable-Amp).</p>										
Remark										

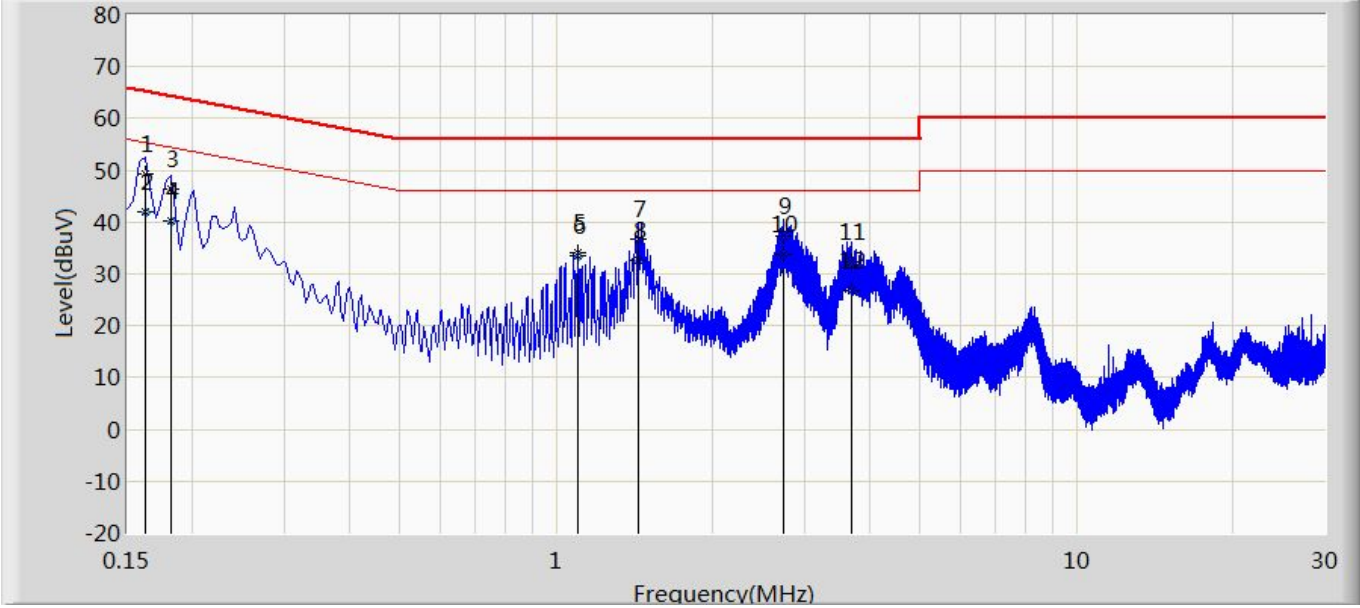
Measurement data		Port under test	AC mains port							
Operating mode / voltage		Mode 2/ PV: 480 Vdc, Battery: 500 Vdc, AC mains: 400 Vac								
Site: AC1		Time: 2022/05/30								
Limit: EN IEC 61000-6-3_AC Mains Port		Margin: 0								
Probe: NNLK 8129_(0.009-30MHz)		Polarity: Line2								
EUT: Storage Inverter		Power: PV: 480 Vdc, Battery: 500 Vdc, AC mains: 400 Vac								
Note: Mode 2										
										
No	Mark	Frequency (MHz)	Measure Level (dBuV)	Reading Level (dBuV)	Over Limit (dB)	Limit (dBuV)	Probe (dB)	Cable (dB)	Amp (dB)	Type
1		0.162	49.286	48.762	-16.075	65.361	0.498	0.025	0.000	QP
2		0.162	41.942	41.418	-13.419	55.361	0.498	0.025	0.000	AV
3		0.182	46.338	45.950	-18.055	64.394	0.362	0.026	0.000	QP
4		0.182	40.159	39.771	-14.235	54.394	0.362	0.026	0.000	AV
5		1.098	33.991	33.331	-22.009	56.000	0.600	0.060	0.000	QP
6		1.098	33.488	32.828	-12.512	46.000	0.600	0.060	0.000	AV
7		1.442	36.666	36.102	-19.334	56.000	0.493	0.071	0.000	QP
8		1.442	32.611	32.047	-13.389	46.000	0.493	0.071	0.000	AV
9		2.742	37.402	36.950	-18.598	56.000	0.347	0.105	0.000	QP
10	*	2.742	33.920	33.468	-12.080	46.000	0.347	0.105	0.000	AV
11		3.702	32.310	31.805	-23.690	56.000	0.382	0.122	0.000	QP
12		3.702	26.693	26.188	-19.307	46.000	0.382	0.122	0.000	AV
<p>Note:</p> <p>1. " * ", means this data is the worst emission level.</p> <p>2. Measurement Level = Reading Level + Factor(Probe+Cable-Amp).</p>										
Remark										

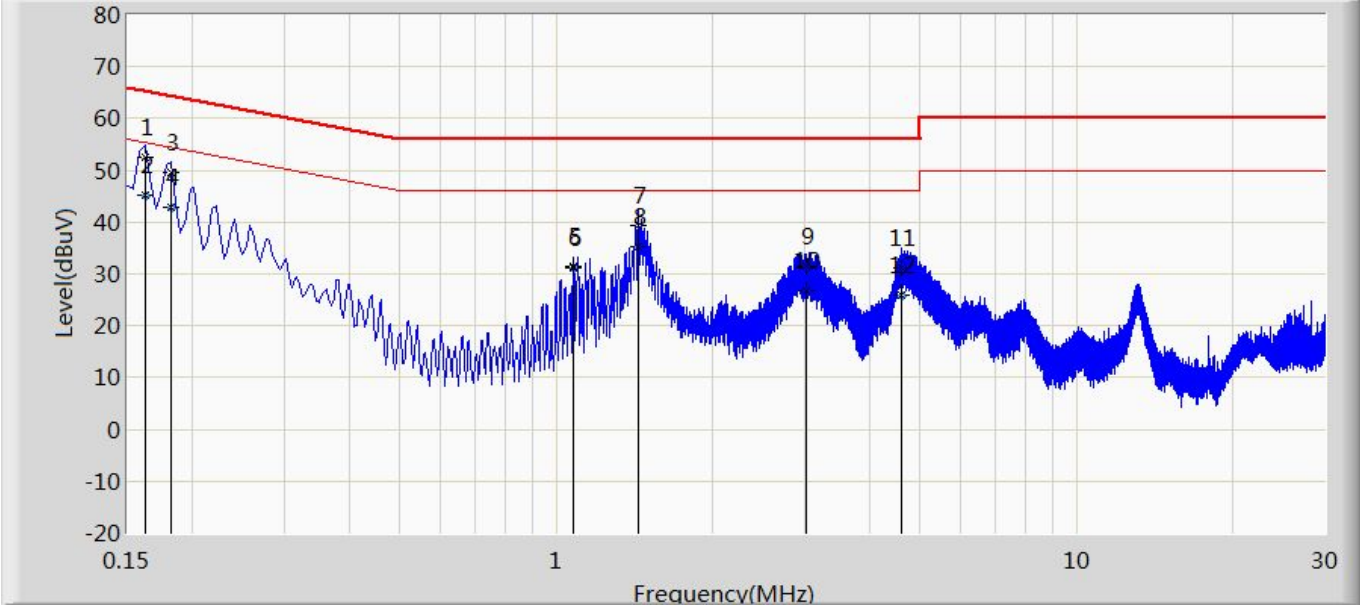
Measurement data		Port under test	AC mains port							
Operating mode / voltage		Mode 2/ PV: 480 Vdc, Battery: 500 Vdc, AC mains: 400 Vac								
Site: AC1		Time: 2022/05/30								
Limit: EN IEC 61000-6-3_AC Mains Port		Margin: 0								
Probe: NNLK 8129_(0.009-30MHz)		Polarity: Line3								
EUT: Storage Inverter		Power: PV: 480 Vdc, Battery: 500 Vdc, AC mains: 400 Vac								
Note: Mode 2										
										
No	Mark	Frequency (MHz)	Measure Level (dBuV)	Reading Level (dBuV)	Over Limit (dB)	Limit (dBuV)	Probe (dB)	Cable (dB)	Amp (dB)	Type
1		0.162	52.611	52.005	-12.749	65.361	0.581	0.025	0.000	QP
2	*	0.162	45.298	44.692	-10.063	55.361	0.581	0.025	0.000	AV
3		0.182	49.576	49.101	-14.818	64.394	0.449	0.026	0.000	QP
4		0.182	42.825	42.350	-11.569	54.394	0.449	0.026	0.000	AV
5		1.082	31.393	30.792	-24.607	56.000	0.542	0.060	0.000	QP
6		1.082	31.286	30.685	-14.714	46.000	0.542	0.060	0.000	AV
7		1.442	39.257	38.637	-16.743	56.000	0.549	0.071	0.000	QP
8		1.442	35.135	34.515	-10.865	46.000	0.549	0.071	0.000	AV
9		3.022	31.410	30.768	-24.590	56.000	0.533	0.110	0.000	QP
10		3.022	26.858	26.216	-19.142	46.000	0.533	0.110	0.000	AV
11		4.622	31.045	30.419	-24.955	56.000	0.490	0.136	0.000	QP
12		4.622	25.770	25.143	-20.230	46.000	0.490	0.136	0.000	AV
<p>Note:</p> <p>1. " * ", means this data is the worst emission level.</p> <p>2. Measurement Level = Reading Level + Factor(Probe+Cable-Amp).</p>										
Remark										

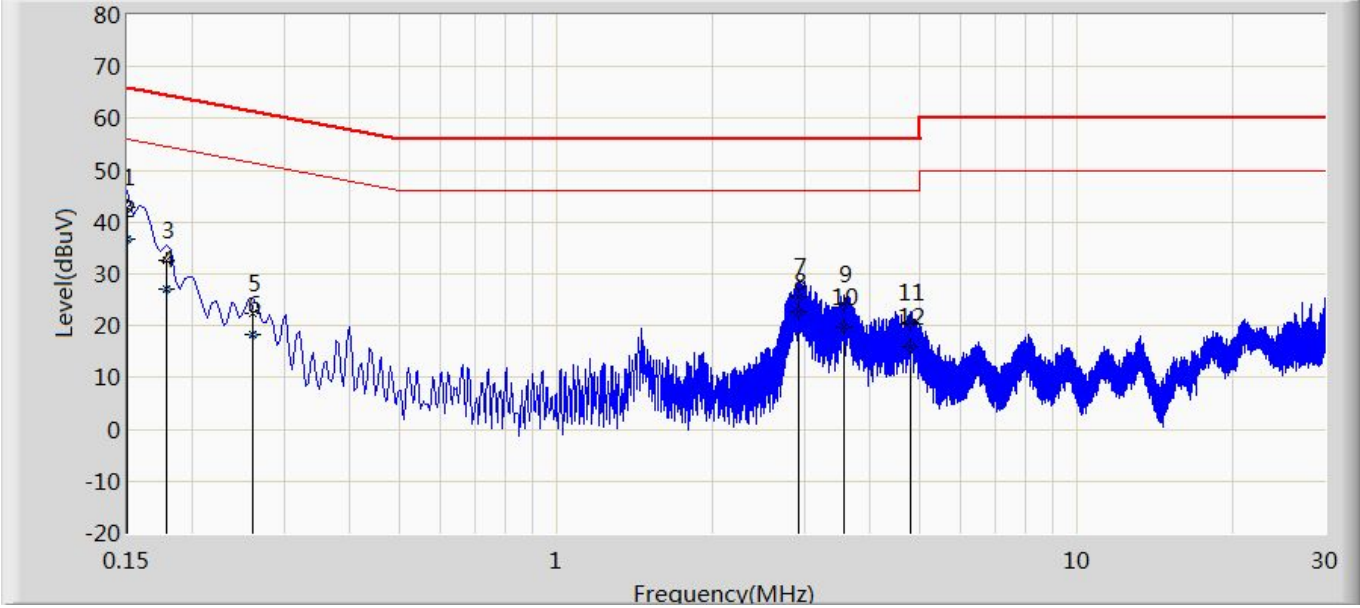
Measurement data		Port under test	AC mains port							
Operating mode / voltage		Mode 2/ PV: 480 Vdc, Battery: 500 Vdc, AC mains: 400 Vac								
Site: AC1		Time: 2022/05/30								
Limit: EN IEC 61000-6-3_AC Mains Port		Margin: 0								
Probe: NNLK 8129_(0.009-30MHz)		Polarity: Neutral								
EUT: Storage Inverter		Power: PV: 480 Vdc, Battery: 500 Vdc, AC mains: 400 Vac								
Note: Mode 2										
										
No	Mark	Frequency (MHz)	Measure Level (dBuV)	Reading Level (dBuV)	Over Limit (dB)	Limit (dBuV)	Probe (dB)	Cable (dB)	Amp (dB)	Type
1		0.150	42.984	42.278	-23.016	66.000	0.681	0.025	0.000	QP
2	*	0.150	36.771	36.064	-19.229	56.000	0.681	0.025	0.000	AV
3		0.178	32.712	32.245	-31.867	64.578	0.441	0.026	0.000	QP
4		0.178	27.095	26.628	-27.484	54.578	0.441	0.026	0.000	AV
5		0.262	22.411	22.189	-38.957	61.368	0.190	0.032	0.000	QP
6		0.262	18.290	18.069	-33.078	51.368	0.190	0.032	0.000	AV
7		2.922	25.746	25.122	-30.254	56.000	0.516	0.108	0.000	QP
8		2.922	22.818	22.194	-23.182	46.000	0.516	0.108	0.000	AV
9		3.578	24.127	23.508	-31.873	56.000	0.498	0.121	0.000	QP
10		3.578	19.784	19.165	-26.216	46.000	0.498	0.121	0.000	AV
11		4.802	20.777	20.172	-35.223	56.000	0.465	0.139	0.000	QP
12		4.802	16.024	15.419	-29.976	46.000	0.465	0.139	0.000	AV
<p>Note:</p> <p>1. " * ", means this data is the worst emission level.</p> <p>2. Measurement Level = Reading Level + Factor(Probe+Cable-Amp).</p>										
Remark										

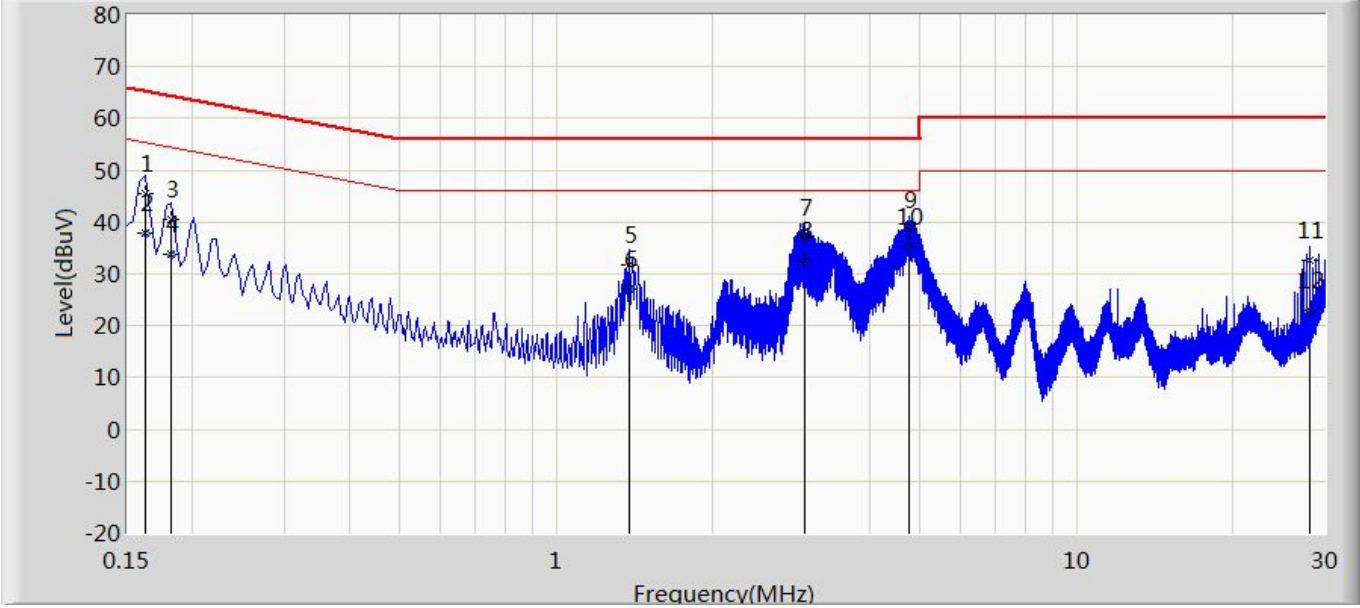
Measurement data		Port under test	AC mains port							
Operating mode / voltage		Mode 3/ PV: 480 Vdc, Battery: 500 Vdc, AC mains: 400 Vac								
Site: AC1		Time: 2022/05/30								
Limit: EN IEC 61000-6-3_AC Mains Port		Margin: 0								
Probe: NNLK 8129_(0.009-30MHz)		Polarity: Line1								
EUT: Storage Inverter		Power: PV: 480 Vdc, Battery: 500 Vdc, AC mains: 400 Vac								
Note: Mode 3										
										
No	Mark	Frequency (MHz)	Measure Level (dBuV)	Reading Level (dBuV)	Over Limit (dB)	Limit (dBuV)	Probe (dB)	Cable (dB)	Amp (dB)	Type
1		0.162	45.449	45.036	-19.912	65.361	0.388	0.025	0.000	QP
2		0.162	37.858	37.445	-17.502	55.361	0.388	0.025	0.000	AV
3		0.182	40.401	40.076	-23.993	64.394	0.300	0.026	0.000	QP
4		0.182	33.923	33.597	-20.471	54.394	0.300	0.026	0.000	AV
5		1.382	31.857	31.316	-24.143	56.000	0.472	0.070	0.000	QP
6		1.382	27.031	26.489	-18.969	46.000	0.472	0.070	0.000	AV
7		3.002	36.970	36.593	-19.030	56.000	0.267	0.110	0.000	QP
8		3.002	32.597	32.220	-13.403	46.000	0.267	0.110	0.000	AV
9		4.762	38.564	38.182	-17.436	56.000	0.243	0.139	0.000	QP
10	*	4.762	35.202	34.820	-10.798	46.000	0.243	0.139	0.000	AV
11		28.046	32.667	32.049	-27.333	60.000	0.278	0.341	0.000	QP
12		28.046	23.116	22.498	-26.884	50.000	0.278	0.341	0.000	AV
<p>Note:</p> <p>1. " * ", means this data is the worst emission level.</p> <p>2. Measurement Level = Reading Level + Factor(Probe+Cable-Amp).</p>										
Remark										

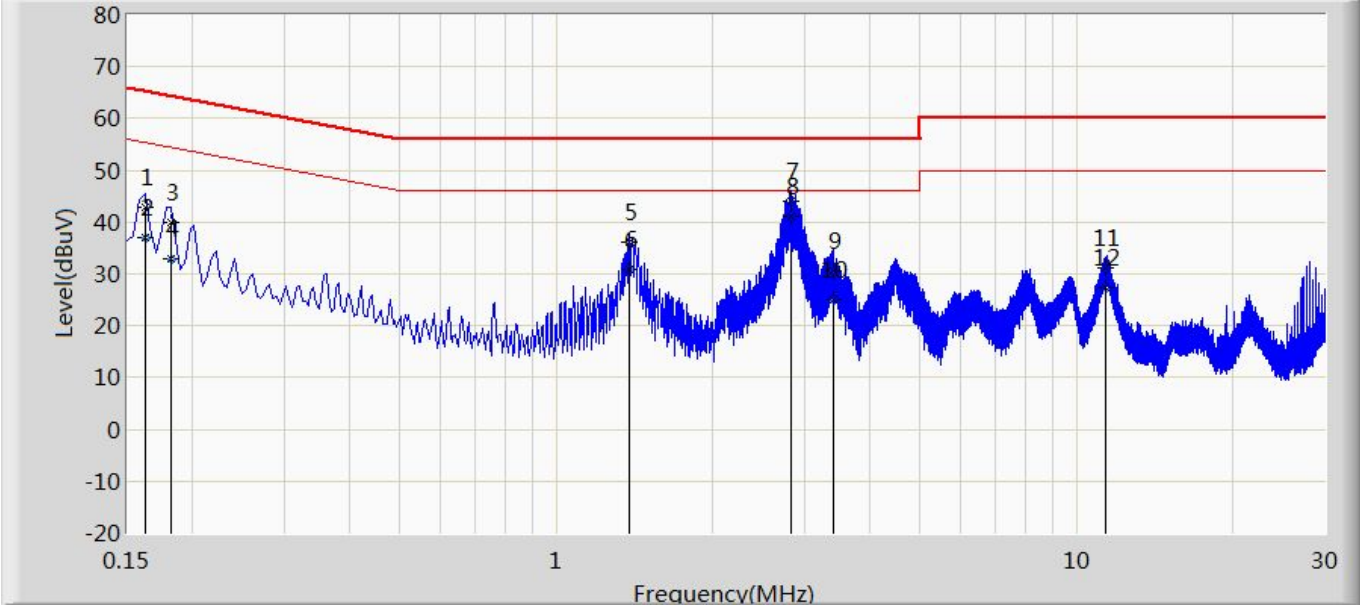
Measurement data		Port under test	AC mains port							
Operating mode / voltage		Mode 3/ PV: 480 Vdc, Battery: 500 Vdc, AC mains: 400 Vac								
Site: AC1		Time: 2022/05/30								
Limit: EN IEC 61000-6-3_AC Mains Port		Margin: 0								
Probe: NNLK 8129_(0.009-30MHz)		Polarity: Line2								
EUT: Storage Inverter		Power: PV: 480 Vdc, Battery: 500 Vdc, AC mains: 400 Vac								
Note: Mode 3										
										
No	Mark	Frequency (MHz)	Measure Level (dBuV)	Reading Level (dBuV)	Over Limit (dB)	Limit (dBuV)	Probe (dB)	Cable (dB)	Amp (dB)	Type
1		0.162	42.907	42.383	-22.454	65.361	0.498	0.025	0.000	QP
2		0.162	36.917	36.393	-18.444	55.361	0.498	0.025	0.000	AV
3		0.182	40.016	39.628	-24.378	64.394	0.362	0.026	0.000	QP
4		0.182	33.030	32.641	-21.364	54.394	0.362	0.026	0.000	AV
5		1.382	36.065	35.483	-19.935	56.000	0.512	0.070	0.000	QP
6		1.382	30.823	30.241	-15.177	46.000	0.512	0.070	0.000	AV
7		2.822	43.926	43.471	-12.074	56.000	0.350	0.106	0.000	QP
8	*	2.822	41.096	40.640	-4.904	46.000	0.350	0.106	0.000	AV
9		3.402	30.561	30.074	-25.439	56.000	0.371	0.117	0.000	QP
10		3.402	24.945	24.457	-21.055	46.000	0.371	0.117	0.000	AV
11		11.402	31.296	30.509	-28.704	60.000	0.572	0.215	0.000	QP
12		11.402	27.502	26.715	-22.498	50.000	0.572	0.215	0.000	AV
<p>Note:</p> <p>1. " * ", means this data is the worst emission level.</p> <p>2. Measurement Level = Reading Level + Factor(Probe+Cable-Amp).</p>										
Remark										

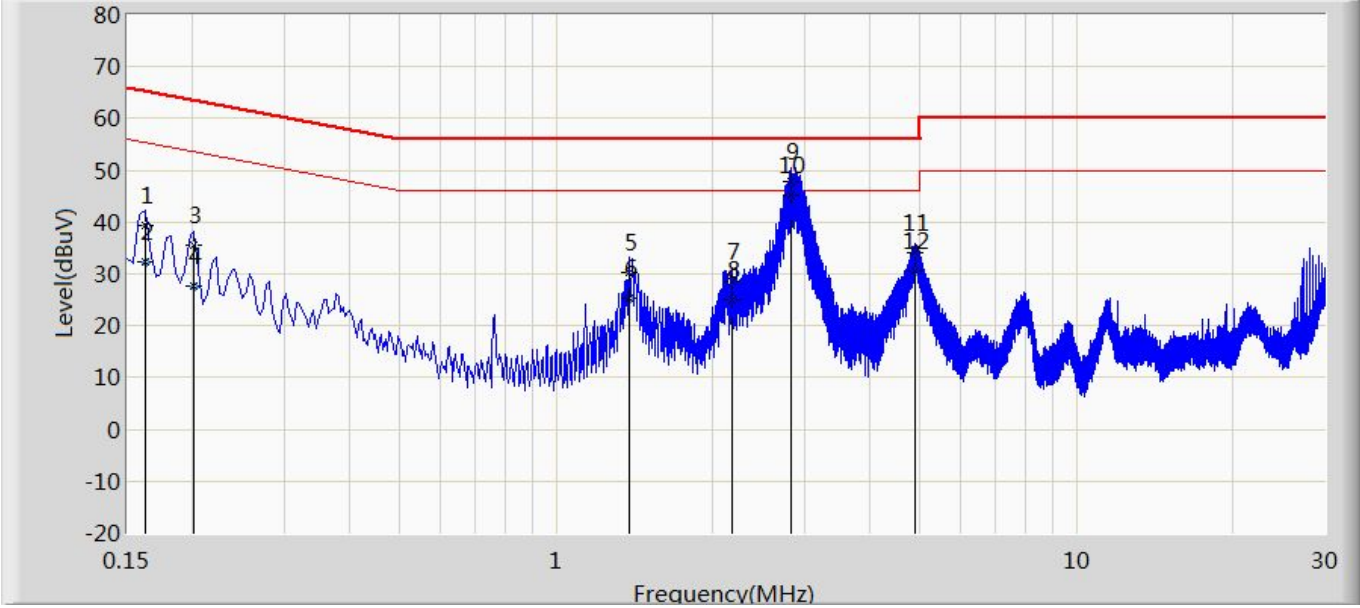
Measurement data		Port under test	AC mains port							
Operating mode / voltage		Mode 3/ PV: 480 Vdc, Battery: 500 Vdc, AC mains: 400 Vac								
Site: AC1		Time: 2022/05/30								
Limit: EN IEC 61000-6-3_AC Mains Port		Margin: 0								
Probe: NNLK 8129_(0.009-30MHz)		Polarity: Line3								
EUT: Storage Inverter		Power: PV: 480 Vdc, Battery: 500 Vdc, AC mains: 400 Vac								
Note: Mode 3										
										
No	Mark	Frequency (MHz)	Measure Level (dBuV)	Reading Level (dBuV)	Over Limit (dB)	Limit (dBuV)	Probe (dB)	Cable (dB)	Amp (dB)	Type
1		0.162	39.396	38.790	-25.965	65.361	0.581	0.025	0.000	QP
2		0.162	32.261	31.655	-23.100	55.361	0.581	0.025	0.000	AV
3		0.202	35.410	35.007	-28.118	63.528	0.375	0.029	0.000	QP
4		0.202	27.599	27.195	-25.929	53.528	0.375	0.029	0.000	AV
5		1.382	30.155	29.537	-25.845	56.000	0.548	0.070	0.000	QP
6		1.382	25.200	24.583	-20.800	46.000	0.548	0.070	0.000	AV
7		2.182	28.527	27.883	-27.473	56.000	0.556	0.089	0.000	QP
8		2.182	24.977	24.333	-21.023	46.000	0.556	0.089	0.000	AV
9		2.822	47.923	47.279	-8.077	56.000	0.538	0.106	0.000	QP
10	*	2.822	45.112	44.468	-0.888	46.000	0.538	0.106	0.000	AV
11		4.902	34.047	33.422	-21.953	56.000	0.483	0.143	0.000	QP
12		4.902	30.556	29.931	-15.444	46.000	0.483	0.143	0.000	AV
<p>Note:</p> <p>1. " * ", means this data is the worst emission level.</p> <p>2. Measurement Level = Reading Level + Factor(Probe+Cable-Amp).</p>										
Remark										

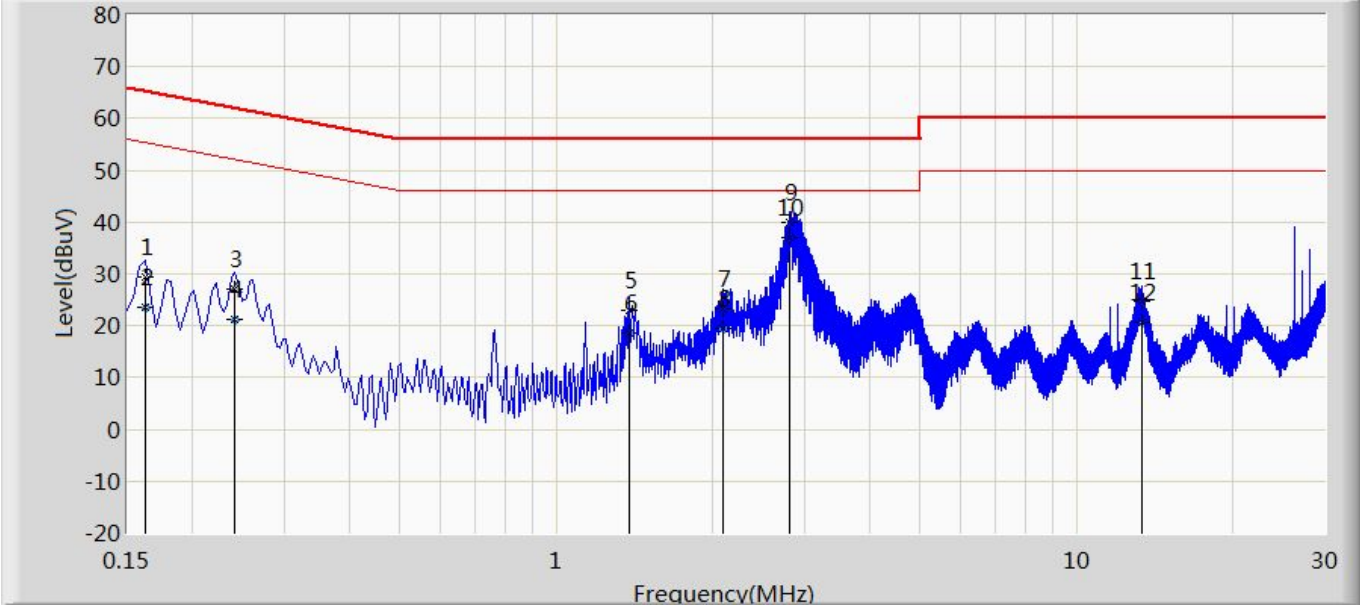
Measurement data		Port under test	AC mains port							
Operating mode / voltage		Mode 3/ PV: 480 Vdc, Battery: 500 Vdc, AC mains: 400 Vac								
Site: AC1		Time: 2022/05/30								
Limit: EN IEC 61000-6-3_AC Mains Port		Margin: 0								
Probe: NNLK 8129_(0.009-30MHz)		Polarity: Neutral								
EUT: Storage Inverter		Power: PV: 480 Vdc, Battery: 500 Vdc, AC mains: 400 Vac								
Note: Mode 3										
										
No	Mark	Frequency (MHz)	Measure Level (dBuV)	Reading Level (dBuV)	Over Limit (dB)	Limit (dBuV)	Probe (dB)	Cable (dB)	Amp (dB)	Type
1		0.162	29.539	28.839	-35.822	65.361	0.675	0.025	0.000	QP
2		0.162	23.583	22.883	-31.778	55.361	0.675	0.025	0.000	AV
3		0.242	27.186	26.989	-34.841	62.027	0.167	0.029	0.000	QP
4		0.242	21.134	20.937	-30.894	52.027	0.167	0.029	0.000	AV
5		1.382	22.947	22.349	-33.053	56.000	0.528	0.070	0.000	QP
6		1.382	18.560	17.963	-27.440	46.000	0.528	0.070	0.000	AV
7		2.098	23.321	22.696	-32.679	56.000	0.537	0.088	0.000	QP
8		2.098	19.363	18.738	-26.637	46.000	0.537	0.088	0.000	AV
9		2.818	39.909	39.285	-16.091	56.000	0.518	0.106	0.000	QP
10	*	2.818	36.964	36.339	-9.036	46.000	0.518	0.106	0.000	AV
11		13.342	24.794	24.376	-35.206	60.000	0.186	0.232	0.000	QP
12		13.342	20.603	20.185	-29.397	50.000	0.186	0.232	0.000	AV
<p>Note:</p> <p>1. " * ", means this data is the worst emission level.</p> <p>2. Measurement Level = Reading Level + Factor(Probe+Cable-Amp).</p>										
Remark										

4.2 Conducted disturbance voltage – DC power port(s)	VERDICT: PASS
---	----------------------

Standard	EN IEC 61000-6-3
Basic standard(s)	EN 55016-2-1

Limits: V-AN

Frequency range [MHz]	Limit: QP [dB(μV) ¹⁾	Limit: AV [dB(μV) ¹⁾	IF BW	Detector(s)
0,15 - 0,50	79	66	9 KHz	QP, CAV
0,50 - 30	73	60	9 KHz	QP, CAV

¹⁾ At the transition frequency, the lower limit applies.

²⁾ Applicable only to ports intended for connection to a local DC power network, or a local battery by a connecting cable exceeding a length of 30 m.

Limits: Δ-AN

Frequency range [MHz]	Limit: QP [dB(μV) ¹⁾	Limit: AV [dB(μV) ¹⁾	IF BW	Detector(s)
0,15 - 0,50	84-74 ²⁾	74-64 ²⁾	9 KHz	QP, CAV
0,50 - 30	74	64	9 KHz	QP, CAV

¹⁾ At the transition frequency, the lower limit applies.

²⁾ The limit decreases linearly with the logarithm of the frequency.

³⁾ Applicable only to ports intended for connection to a local DC power network, or a local battery by a connecting cable exceeding a length of 30 m.

Performed measurements

Port under test	Terminal			
<input checked="" type="checkbox"/> DC power input port (PV port)	<input checked="" type="checkbox"/> Positive (+)	<input checked="" type="checkbox"/> Negative (-)		
<input type="checkbox"/> Other:	<input type="checkbox"/> Positive (+)	<input type="checkbox"/> Negative (-)		
Voltage – Input [VDC]	480 Vdc			
Voltage – Output [V _{DC}]	---			
Test method applied	<input checked="" type="checkbox"/> Artificial mains network			
	<input type="checkbox"/> Voltage probe			
Test setup	<input checked="" type="checkbox"/> Table top	<input type="checkbox"/> Artificial hand applied		
	<input type="checkbox"/> Floor standing	<input type="checkbox"/> Other:		
	Refer to the Annex 2 for test setup photo(s).			
Operating mode(s) used	Mode 1, 2, 3			
Remark	---			

See next page.

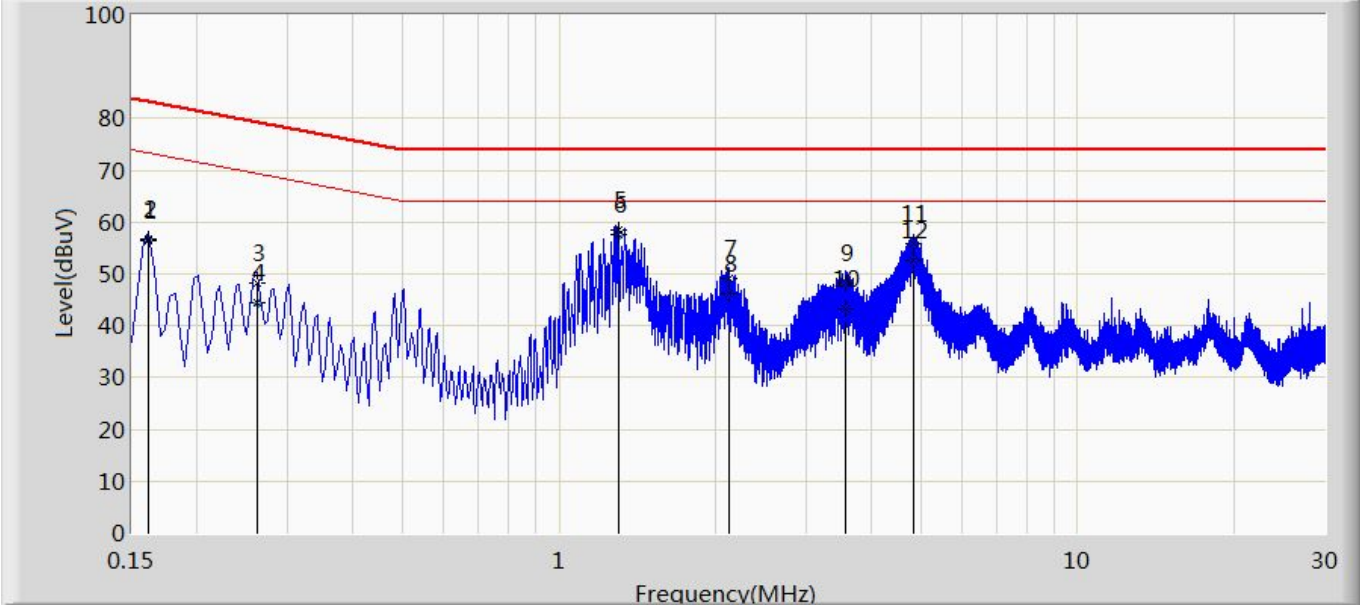
Measurement data		Port under test	DC power port (Positive)							
Operating mode / voltage		Mode 1/ PV: 480 Vdc, Battery: 500 Vdc, AC mains: 400 Vac								
Site: AC1		Time: 2022/05/30								
Limit: EN IEC 61000-6-3-DC Power Port		Margin: 0								
Probe: PVDC 8301 (0.15-30MHz)		Polarity: Positive								
EUT: Storage Inverter		Power: PV: 480 Vdc, Battery: 500 Vdc, AC mains: 400 Vac								
Note: Mode 1										
										
No	Mark	Frequency (MHz)	Measure Level (dBuV)	Reading Level (dBuV)	Over Limit (dB)	Limit (dBuV)	Probe (dB)	Cable (dB)	Amp (dB)	Type
1		0.162	56.573	36.802	-26.788	83.361	19.745	0.025	0.000	QP
2		0.162	56.698	36.927	-16.663	73.361	19.745	0.025	0.000	AV
3		0.262	48.249	28.930	-31.118	79.368	19.288	0.032	0.000	QP
4		0.262	44.302	24.982	-25.066	69.368	19.288	0.032	0.000	AV
5		1.302	58.510	40.344	-15.490	74.000	18.100	0.067	0.000	QP
6	*	1.302	57.590	39.424	-6.410	64.000	18.100	0.067	0.000	AV
7		2.122	49.080	30.874	-24.920	74.000	18.116	0.090	0.000	QP
8		2.122	46.124	27.918	-17.876	64.000	18.116	0.090	0.000	AV
9		3.562	48.252	29.824	-25.748	74.000	18.308	0.120	0.000	QP
10		3.562	43.361	24.934	-20.639	64.000	18.308	0.120	0.000	AV
11		4.838	55.904	37.286	-18.096	74.000	18.478	0.139	0.000	QP
12		4.838	52.658	34.040	-11.342	64.000	18.478	0.139	0.000	AV
<p>Note:</p> <p>1. " * ", means this data is the worst emission level.</p> <p>2. Measurement Level = Reading Level + Factor(Probe+Cable-Amp).</p>										
Remark										

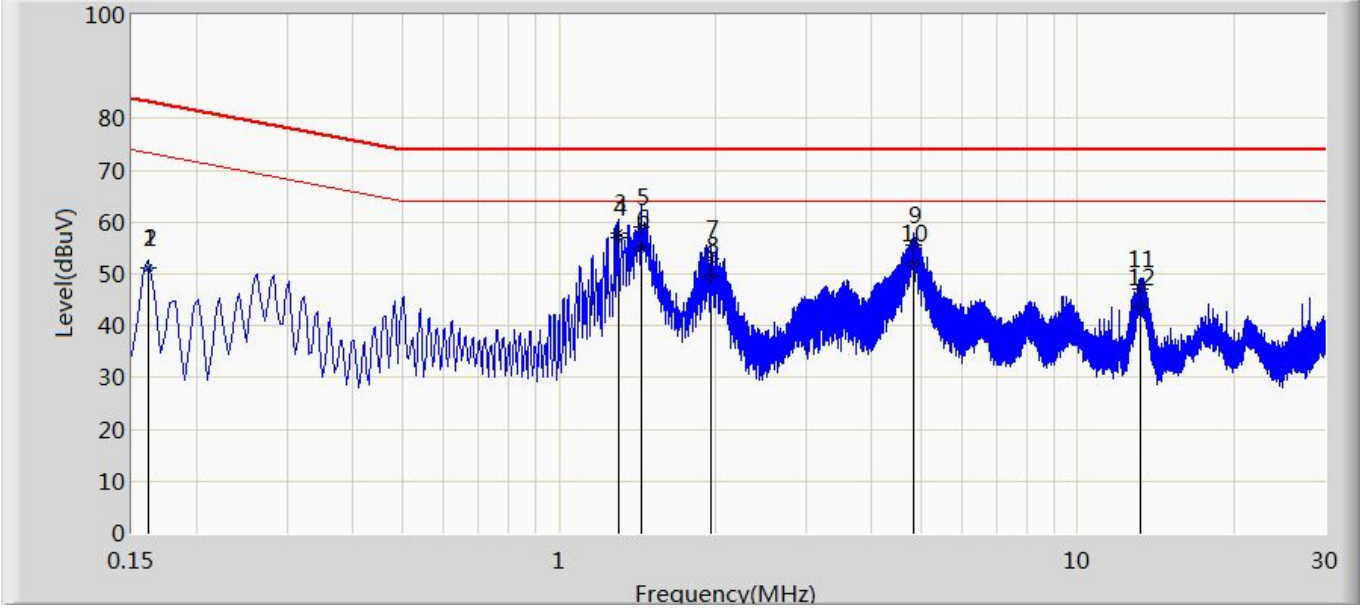
Measurement data		Port under test	DC power port (Negative)							
Operating mode / voltage		Mode 1/ PV: 480 Vdc, Battery: 500 Vdc, AC mains: 400 Vac								
Site: AC1		Time: 2022/05/30								
Limit: EN IEC 61000-6-3-DC Power Port		Margin: 0								
Probe: PVDC 8301 (0.15-30MHz)		Polarity: Negative								
EUT: Storage Inverter		Power: PV: 480 Vdc, Battery: 500 Vdc, AC mains: 400 Vac								
Note: Mode 1										
										
No	Mark	Frequency (MHz)	Measure Level (dBuV)	Reading Level (dBuV)	Over Limit (dB)	Limit (dBuV)	Probe (dB)	Cable (dB)	Amp (dB)	Type
1		0.162	51.278	31.507	-32.083	83.361	19.745	0.025	0.000	QP
2		0.162	51.286	31.516	-22.074	73.361	19.745	0.025	0.000	AV
3		1.302	57.781	39.615	-16.219	74.000	18.100	0.067	0.000	QP
4	*	1.302	56.984	38.818	-7.016	64.000	18.100	0.067	0.000	AV
5		1.442	59.117	40.946	-14.883	74.000	18.100	0.071	0.000	QP
6		1.442	55.034	36.863	-8.966	64.000	18.100	0.071	0.000	AV
7		1.958	52.942	34.758	-21.058	74.000	18.100	0.084	0.000	QP
8		1.958	49.845	31.660	-14.155	64.000	18.100	0.084	0.000	AV
9		4.838	55.454	37.025	-18.546	74.000	18.289	0.139	0.000	QP
10		4.838	52.132	33.703	-11.868	64.000	18.289	0.139	0.000	AV
11		13.222	47.123	28.270	-26.877	74.000	18.622	0.231	0.000	QP
12		13.222	43.626	24.773	-20.374	64.000	18.622	0.231	0.000	AV
<p>Note:</p> <p>1. " * ", means this data is the worst emission level.</p> <p>2. Measurement Level = Reading Level + Factor(Probe+Cable-Amp).</p>										
Remark										

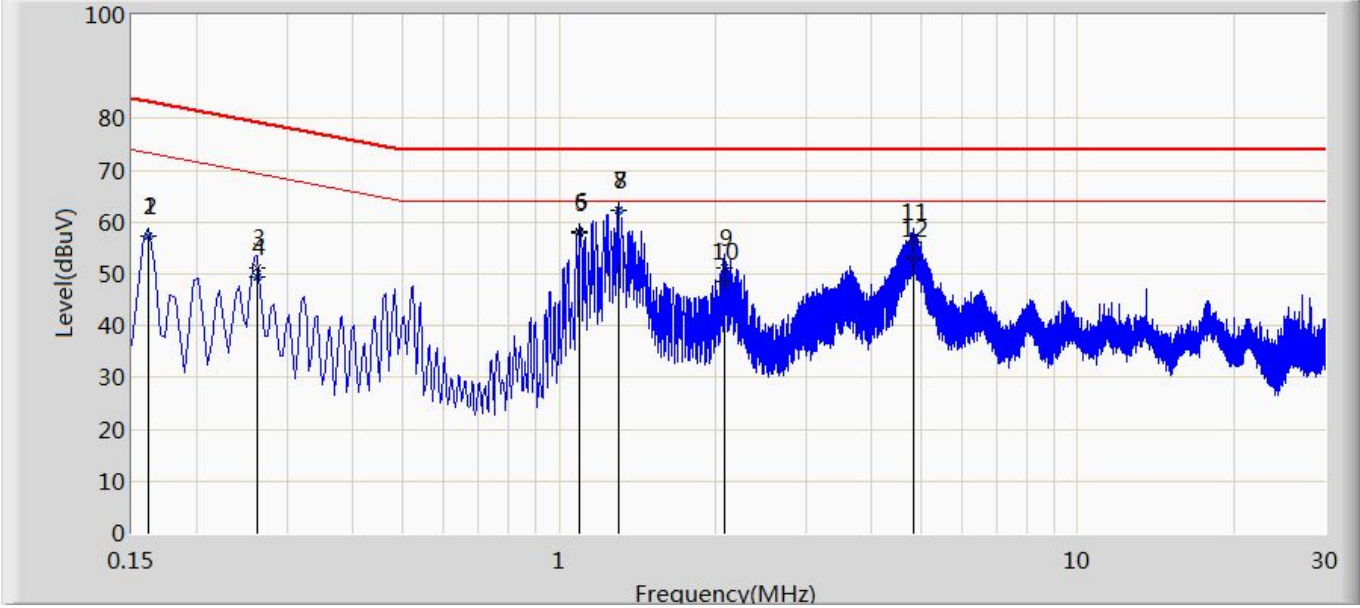
Measurement data		Port under test	DC power port (Positive)							
Operating mode / voltage		Mode 2/ PV: 480 Vdc, Battery: 500 Vdc, AC mains: 400 Vac								
Site: AC1		Time: 2022/05/30								
Limit: EN IEC 61000-6-3-DC Power Port		Margin: 0								
Probe: PVDC 8301 (0.15-30MHz)		Polarity: Positive								
EUT: Storage Inverter		Power: PV: 480 Vdc, Battery: 500 Vdc, AC mains: 400 Vac								
Note: Mode 2										
										
No	Mark	Frequency (MHz)	Measure Level (dBuV)	Reading Level (dBuV)	Over Limit (dB)	Limit (dBuV)	Probe (dB)	Cable (dB)	Amp (dB)	Type
1		0.162	57.310	37.539	-26.051	83.361	19.745	0.025	0.000	QP
2		0.162	57.365	37.594	-15.996	73.361	19.745	0.025	0.000	AV
3		0.262	51.203	31.883	-28.165	79.368	19.288	0.032	0.000	QP
4		0.262	49.452	30.132	-19.916	69.368	19.288	0.032	0.000	AV
5		1.098	57.936	39.776	-16.064	74.000	18.100	0.060	0.000	QP
6		1.098	58.050	39.890	-5.950	64.000	18.100	0.060	0.000	AV
7		1.302	62.355	44.188	-11.645	74.000	18.100	0.067	0.000	QP
8	*	1.302	62.293	44.126	-1.707	64.000	18.100	0.067	0.000	AV
9		2.082	51.294	33.095	-22.706	74.000	18.111	0.088	0.000	QP
10		2.082	48.425	30.227	-15.575	64.000	18.111	0.088	0.000	AV
11		4.822	56.123	37.507	-17.877	74.000	18.476	0.139	0.000	QP
12		4.822	52.988	34.372	-11.012	64.000	18.476	0.139	0.000	AV
<p>Note:</p> <p>1. " * ", means this data is the worst emission level.</p> <p>2. Measurement Level = Reading Level + Factor(Probe+Cable-Amp).</p>										
Remark										

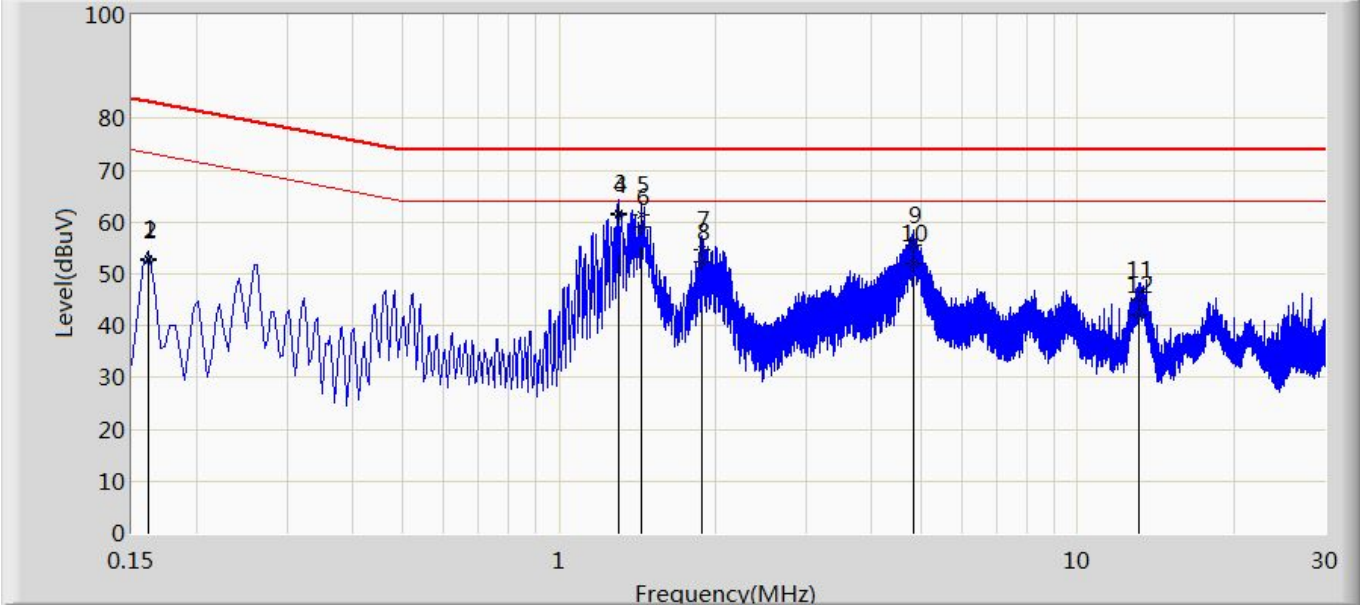
Measurement data		Port under test	DC power port (Negative)							
Operating mode / voltage		Mode 2/ PV: 480 Vdc, Battery: 500 Vdc, AC mains: 400 Vac								
Site: AC1		Time: 2022/05/30								
Limit: E EN IEC 61000-6-3-DC Power Port		Margin: 0								
Probe: PVDC 8301 (0.15-30MHz)		Polarity: Negative								
EUT: Storage Inverter		Power: PV: 480 Vdc, Battery: 500 Vdc, AC mains: 400 Vac								
Note: Mode 2										
										
No	Mark	Frequency (MHz)	Measure Level (dBuV)	Reading Level (dBuV)	Over Limit (dB)	Limit (dBuV)	Probe (dB)	Cable (dB)	Amp (dB)	Type
1		0.162	52.924	33.153	-30.437	83.361	19.745	0.025	0.000	QP
2		0.162	52.748	32.978	-20.612	73.361	19.745	0.025	0.000	AV
3		1.302	61.685	43.518	-12.315	74.000	18.100	0.067	0.000	QP
4	*	1.302	61.476	43.309	-2.524	64.000	18.100	0.067	0.000	AV
5		1.442	61.324	43.154	-12.676	74.000	18.100	0.071	0.000	QP
6		1.442	58.987	40.816	-5.013	64.000	18.100	0.071	0.000	AV
7		1.882	54.617	36.436	-19.383	74.000	18.100	0.081	0.000	QP
8		1.882	52.224	34.043	-11.776	64.000	18.100	0.081	0.000	AV
9		4.838	55.435	37.006	-18.565	74.000	18.289	0.139	0.000	QP
10		4.838	52.079	33.651	-11.921	64.000	18.289	0.139	0.000	AV
11		13.102	45.064	26.224	-28.936	74.000	18.610	0.230	0.000	QP
12		13.102	42.118	23.279	-21.882	64.000	18.610	0.230	0.000	AV
<p>Note:</p> <p>1. " * ", means this data is the worst emission level.</p> <p>2. Measurement Level = Reading Level + Factor(Probe+Cable-Amp).</p>										
Remark										

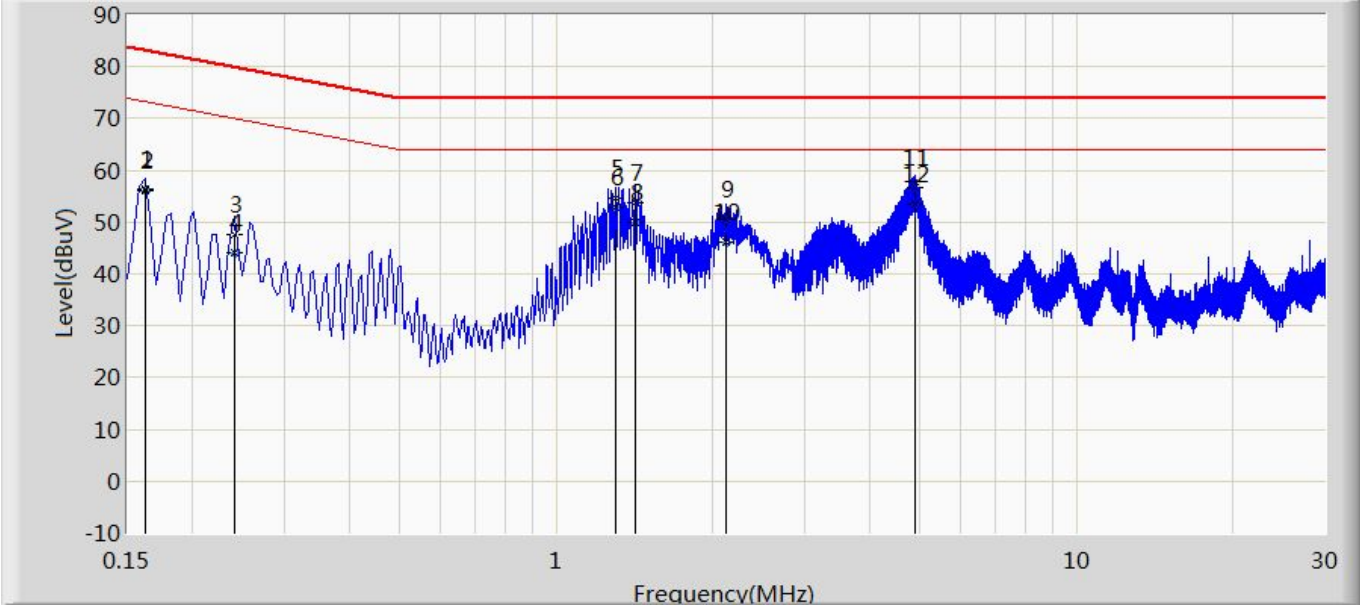
Measurement data		Port under test	DC power port (Positive)							
Operating mode / voltage		Mode 3/ PV: 480 Vdc, Battery: 500 Vdc, AC mains: 400 Vac								
Site: AC1		Time: 2022/05/30								
Limit: EN IEC 61000-6-3-DC Power Port		Margin: 0								
Probe: PVDC 8301 (0.15-30MHz)		Polarity: Positive								
EUT: Storage Inverter		Power: PV: 480 Vdc, Battery: 500 Vdc, AC mains: 400 Vac								
Note: Mode 3										
										
No	Mark	Frequency (MHz)	Measure Level (dBuV)	Reading Level (dBuV)	Over Limit (dB)	Limit (dBuV)	Probe (dB)	Cable (dB)	Amp (dB)	Type
1		0.162	56.429	36.658	-26.932	83.361	19.745	0.025	0.000	QP
2		0.162	56.096	36.326	-17.265	73.361	19.745	0.025	0.000	AV
3		0.242	47.701	28.292	-32.326	80.027	19.380	0.029	0.000	QP
4		0.242	44.174	24.765	-25.854	70.027	19.380	0.029	0.000	AV
5		1.302	54.636	36.470	-19.364	74.000	18.100	0.067	0.000	QP
6		1.302	52.873	34.707	-11.127	64.000	18.100	0.067	0.000	AV
7		1.422	53.697	35.527	-20.303	74.000	18.100	0.070	0.000	QP
8		1.422	49.904	31.734	-14.096	64.000	18.100	0.070	0.000	AV
9		2.122	50.557	32.351	-23.443	74.000	18.116	0.090	0.000	QP
10		2.122	46.012	27.806	-17.988	64.000	18.116	0.090	0.000	AV
11		4.902	56.648	38.018	-17.352	74.000	18.487	0.143	0.000	QP
12	*	4.902	53.330	34.700	-10.670	64.000	18.487	0.143	0.000	AV
Note: 1. " * ", means this data is the worst emission level. 2. Measurement Level = Reading Level + Factor(Probe+Cable-Amp).										
Remark										

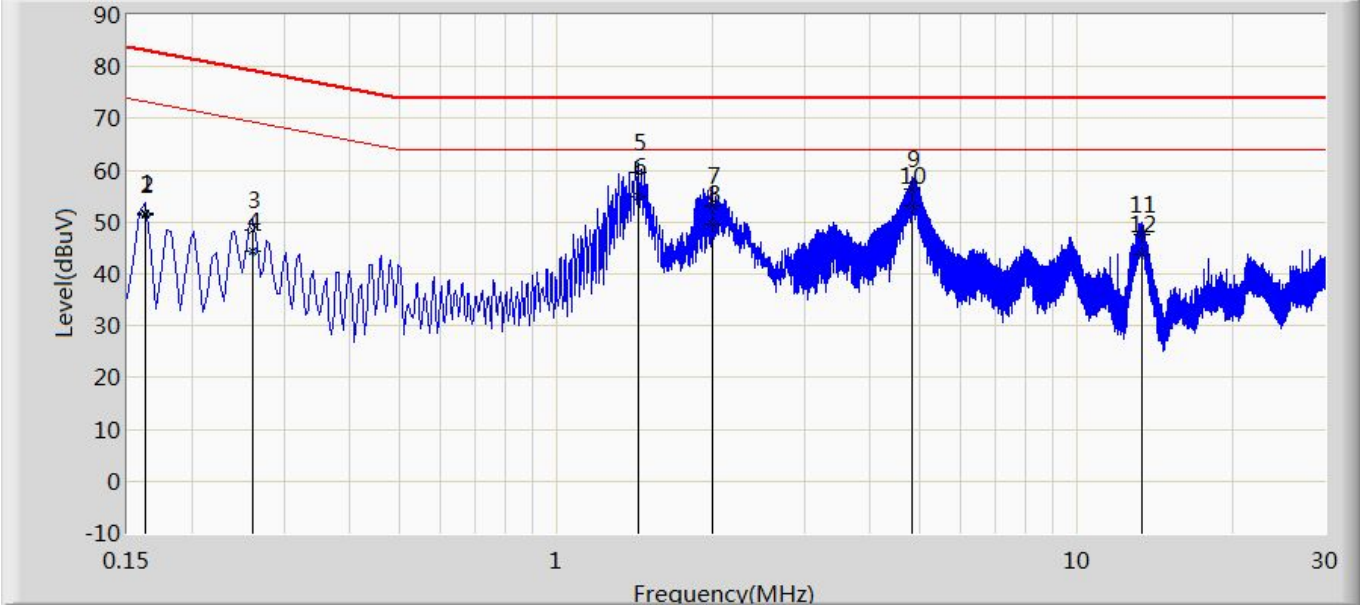
Measurement data		Port under test	DC power port (Negative)							
Operating mode / voltage		Mode 3/ PV: 480 Vdc, Battery: 500 Vdc, AC mains: 400 Vac								
Site: AC1		Time: 2022/05/30								
Limit: EN IEC 61000-6-3-DC Power Port		Margin: 0								
Probe: PVDC 8301 (0.15-30MHz)		Polarity: Negative								
EUT: Storage Inverter		Power: PV: 480 Vdc, Battery: 500 Vdc, AC mains: 400 Vac								
Note: Mode 3										
										
No	Mark	Frequency (MHz)	Measure Level (dBuV)	Reading Level (dBuV)	Over Limit (dB)	Limit (dBuV)	Probe (dB)	Cable (dB)	Amp (dB)	Type
1		0.162	51.771	32.001	-31.590	83.361	19.745	0.025	0.000	QP
2		0.162	51.323	31.552	-22.038	73.361	19.745	0.025	0.000	AV
3		0.262	48.542	29.222	-30.826	79.368	19.288	0.032	0.000	QP
4		0.262	44.293	24.973	-25.075	69.368	19.288	0.032	0.000	AV
5		1.438	59.625	41.455	-14.375	74.000	18.100	0.071	0.000	QP
6	*	1.438	55.030	36.859	-8.970	64.000	18.100	0.071	0.000	AV
7		2.002	53.019	34.833	-20.981	74.000	18.100	0.085	0.000	QP
8		2.002	49.519	31.334	-14.481	64.000	18.100	0.085	0.000	AV
9		4.842	56.300	37.871	-17.700	74.000	18.289	0.140	0.000	QP
10		4.842	53.036	34.607	-10.964	64.000	18.289	0.140	0.000	AV
11		13.322	47.680	28.815	-26.320	74.000	18.632	0.232	0.000	QP
12		13.322	43.691	24.826	-20.309	64.000	18.632	0.232	0.000	AV
<p>Note:</p> <p>1. " * ", means this data is the worst emission level.</p> <p>2. Measurement Level = Reading Level + Factor(Probe+Cable-Amp).</p>										
Remark										

4.3 Conducted disturbance voltage – Telecommunications network port	VERDICT: N/A
--	---------------------

Standard	EN IEC 61000-6-3
Basic standard(s)	EN 55032, EN 55016-2-1

Limits

Frequency range [MHz]	Limit: QP [dB(μV) ¹⁾	Limit: AV [dB(μV) ¹⁾	IF BW	Detector(s)
0,15 - 0,50	84 – 74 ²⁾	74 – 64 ²⁾	9 KHz	QP, CAV
0,50 - 30	74	64	9 KHz	QP, CAV

¹⁾ At the transition frequency, the lower limit applies.

²⁾ The limit decreases linearly with the logarithm of the frequency.

Performed measurements

Port under test				
<input type="checkbox"/>	LAN / Ethernet	<input type="checkbox"/>	Other:	
<input type="checkbox"/>	Other:	<input type="checkbox"/>	Other:	
Voltage – Mains [V] ---				
Frequency – Mains [Hz] ---				
Test method applied	<input type="checkbox"/>	ISN – Impedance Stabilisation Network		
	<input type="checkbox"/>	Voltage probe		
	<input type="checkbox"/>	Current probe		
	<input type="checkbox"/>	Artificial mains network		
	<input type="checkbox"/>	Other:		
Test setup	<input type="checkbox"/>	Table top	<input type="checkbox"/>	Artificial hand applied
	<input type="checkbox"/>	Floor standing	<input type="checkbox"/>	Other:
	Refer to the Annex 2 for test setup photo(s).			
Operating mode(s) used ---				
Remark ---				

See next page.

Measurement data	Port under test	
Operating mode / voltage / frequency used during the test		
<p>The wired network port of the EUT is only for internal software upgrade, not connected to the external network, so it needs not to perform the test item.</p>		
Remark		

4.4 Radiated electromagnetic disturbances (30 – 1000 MHz)	VERDICT: PASS
--	----------------------

Standard	EN IEC 61000-6-3
Basic standard(s)	EN 55016-2-3
Test method	Antenna method according to EN 55016-2-3 standard.
<u>Supplementary information:</u>	

Limits

Frequency [MHz]	Limit: QP [dB(μV/m) ¹⁾]		IF BW	Detector
	@3 m.	@10 m.		
30 - 230	40	30	120 KHz	QP
230 - 1000	47	37	120 KHz	QP

¹⁾ At the transition frequency, the lower limit applies.

Performed measurements

Port under test	Enclosure			
Voltage – Mains [V]	PV: 480 Vdc, Battery: 500 Vdc, AC mains: 400 Vac			
Frequency – Mains [Hz]	50 Hz			
Test method applied	<input type="checkbox"/>	OATS or SAC with measurement distance [m]: 3 m.		
	<input checked="" type="checkbox"/>	OATS or SAC with measurement distance [m]: 10 m.		
Test setup	<input checked="" type="checkbox"/>	Equipment on a table of 80 cm height		
	<input type="checkbox"/>	Equipment on the floor (insulated from ground plane)		
	<input type="checkbox"/>	Other:		
	Refer to the Annex 2 for test setup photo(s).			
Operating mode(s) used	Mode 1, 2, 3			
Remark	---			

See next page.

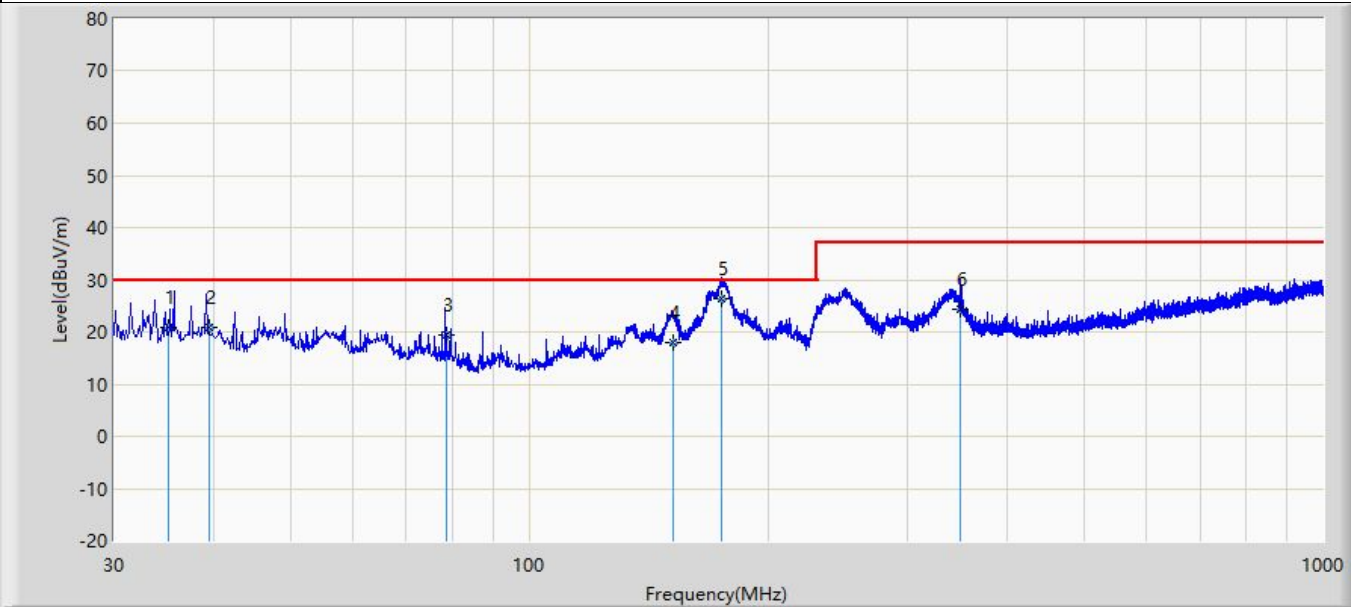
Measurement data		<input checked="" type="checkbox"/>		Horizontal		<input type="checkbox"/>		Vertical				
Operating mode / voltage / frequency used during the test				Mode 1/ PV: 480 Vdc, Battery: 500 Vdc, AC mains: 400 Vac								
Site: AC1				Time: 2022/05/24								
Limit: EN IEC 61000-6-3_RE (10m)				Margin: 0								
Probe: VULB9168_01099(30-1000MHz)				Polarity: Horizontal								
EUT: Storage Inverter				Power: PV: 480 Vdc, Battery: 500 Vdc, AC mains: 400 Vac								
Note: Mode 1												
												
No	Mark	Frequency (MHz)	Measure Level (dBuV/m)	Reading Level (dBuV)	Over Limit (dB)	Limit (dBuV/m)	Probe (dB/m)	Cable (dB)	Amp (dB)	Ant Pos (cm)	Table Pos (deg)	Type
1		35.183	20.920	28.900	-9.080	30.000	12.520	1.056	21.557	146	258	QP
2		39.564	20.816	28.400	-9.184	30.000	12.906	1.126	21.616	156	189	QP
3		78.564	19.353	29.800	-10.647	30.000	9.543	1.634	21.624	163	216	QP
4		151.687	18.002	23.900	-11.998	30.000	13.321	2.355	21.575	183	324	QP
5	*	175.072	26.438	33.000	-3.562	30.000	12.441	2.552	21.554	400	62	QP
6		349.635	24.398	27.500	-12.602	37.000	14.371	3.787	21.260	180	345	QP
<p>Note:</p> <p>1. " * ", means this data is the worst emission level.</p> <p>2. Measurement Level = Reading Level + Factor(Probe+Cable-Amp).</p>												
Remark												

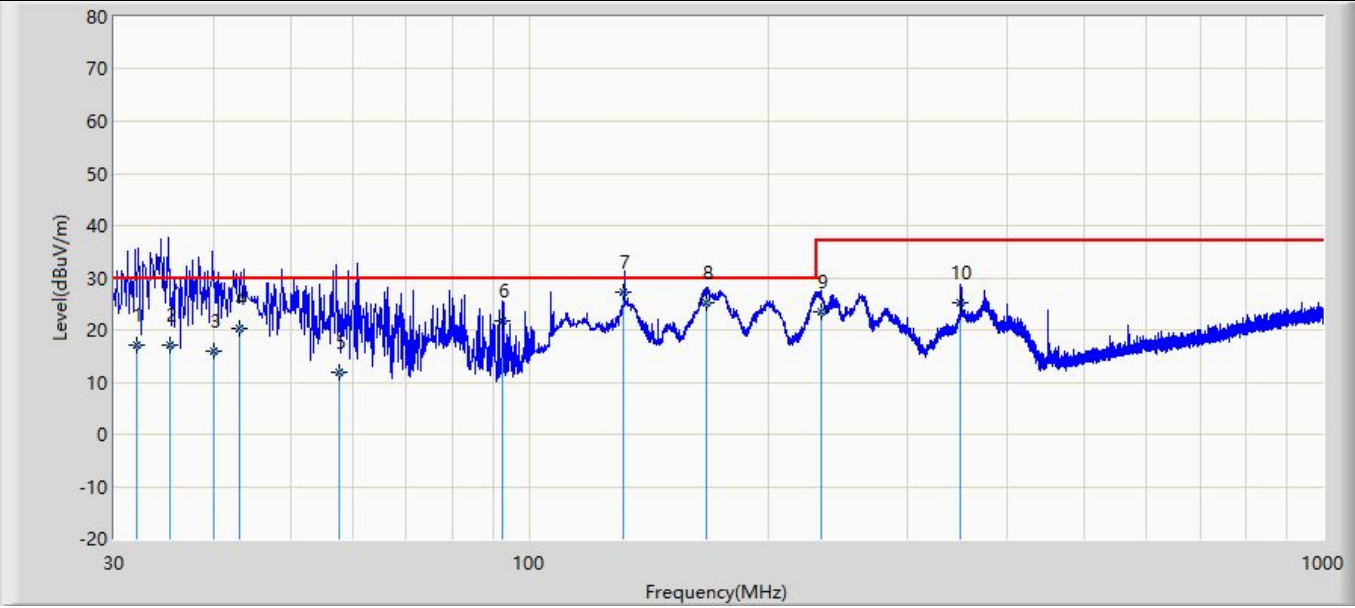
Measurement data		<input type="checkbox"/>	Horizontal		<input checked="" type="checkbox"/>	Vertical						
Operating mode / voltage / frequency used during the test				Mode 1/ PV: 480 Vdc, Battery: 500 Vdc, AC mains: 400 Vac								
Site: AC1				Time: 2022/05/24								
Limit: EN IEC 61000-6-3_RE (10m)				Margin: 0								
Probe: VULB9168_01100(30-1000MHz)				Polarity: Vertical								
EUT: Storage Inverter				Power: PV: 480 Vdc, Battery: 500 Vdc, AC mains: 400 Vac								
Note: Mode 1												
												
No	Mark	Frequency (MHz)	Measure Level (dBuV/m)	Reading Level (dBuV)	Over Limit (dB)	Limit (dBuV/m)	Probe (dB/m)	Cable (dB)	Amp (dB)	Ant Pos (cm)	Table Pos (deg)	Type
1		32.049	17.054	36.400	-12.946	30.000	12.603	1.125	33.073	100	292	QP
2		35.340	16.989	36.200	-13.011	30.000	12.767	1.186	33.164	100	213	QP
3		40.067	15.946	34.900	-14.054	30.000	13.011	1.271	33.236	300	212	QP
4		43.208	20.212	38.900	-9.788	30.000	13.256	1.323	33.267	100	289	QP
5		57.654	11.971	30.500	-18.029	30.000	13.340	1.546	33.415	200	332	QP
6		92.654	21.767	45.400	-8.233	30.000	7.919	2.003	33.555	163	210	QP
7	*	131.654	27.346	46.800	-2.654	30.000	11.657	2.433	33.544	159	249	QP
8		167.460	25.268	43.500	-4.732	30.000	12.541	2.782	33.555	289	274	QP
9		233.346	23.525	42.800	-13.475	37.000	10.767	3.356	33.399	156	315	QP
10		349.163	25.085	39.800	-11.915	37.000	14.233	4.223	33.171	163	324	QP
<p>Note:</p> <p>1. " * ", means this data is the worst emission level.</p> <p>2. Measurement Level = Reading Level + Factor(Probe+Cable-Amp).</p>												
Remark												

Measurement data		<input checked="" type="checkbox"/>		Horizontal		<input type="checkbox"/>		Vertical				
Operating mode / voltage / frequency used during the test				Mode 2/ PV: 480 Vdc, Battery: 500 Vdc, AC mains: 400 Vac								
Site: AC1				Time: 2022/05/24								
Limit: EN IEC 61000-6-3_RE (10m)				Margin: 0								
Probe: VULB9168_01099(30-1000MHz)				Polarity: Horizontal								
EUT: Storage Inverter				Power: PV: 480 Vdc, Battery: 500 Vdc, AC mains: 400 Vac								
Note: Mode 2												
												
No	Mark	Frequency (MHz)	Measure Level (dBuV/m)	Reading Level (dBuV)	Over Limit (dB)	Limit (dBuV/m)	Probe (dB/m)	Cable (dB)	Amp (dB)	Ant Pos (cm)	Table Pos (deg)	Type
1		39.179	20.999	28.600	-9.001	30.000	12.880	1.120	21.601	163	321	QP
2		79.368	15.163	25.800	-14.837	30.000	9.330	1.644	21.611	156	215	QP
3		183.593	19.344	26.800	-10.656	30.000	11.389	2.621	21.466	165	125	QP
4	*	226.213	27.785	36.400	-2.215	30.000	9.858	2.955	21.428	400	48	QP
5		349.654	24.401	27.500	-12.599	37.000	14.372	3.787	21.258	156	125	QP
6		832.163	25.296	15.600	-11.704	37.000	23.333	6.361	19.998	135	215	QP
Note:												
1. " * ", means this data is the worst emission level.												
2. Measurement Level = Reading Level + Factor(Probe+Cable-Amp).												
Remark												

Measurement data		<input type="checkbox"/>	Horizontal		<input checked="" type="checkbox"/>	Vertical						
Operating mode / voltage / frequency used during the test				Mode 2/ PV: 480 Vdc, Battery: 500 Vdc, AC mains: 400 Vac								
Site: AC1				Time: 2022/05/24								
Limit: EN IEC 61000-6-3_RE (10m)				Margin: 0								
Probe: VULB9168_01100(30-1000MHz)				Polarity: Vertical								
EUT: Storage Inverter				Power: PV: 480 Vdc, Battery: 500 Vdc, AC mains: 400 Vac								
Note: Mode 2												
												
No	Mark	Frequency (MHz)	Measure Level (dBuV/m)	Reading Level (dBuV)	Over Limit (dB)	Limit (dBuV/m)	Probe (dB/m)	Cable (dB)	Amp (dB)	Ant Pos (cm)	Table Pos (deg)	Type
1		37.265	10.220	29.300	-19.780	30.000	12.863	1.217	33.160	300	156	QP
2		38.654	26.537	45.600	-3.463	30.000	12.932	1.242	33.237	143	248	QP
3		52.654	21.199	39.500	-8.801	30.000	13.640	1.469	33.411	163	215	QP
4		183.963	25.107	44.400	-4.893	30.000	11.283	2.932	33.508	100	329	QP
5	*	229.778	28.371	48.000	-1.629	30.000	10.429	3.327	33.386	100	219	QP
6		375.324	28.673	42.600	-8.327	37.000	14.782	4.399	33.108	189	354	QP
<p>Note:</p> <p>1. " * ", means this data is the worst emission level.</p> <p>2. Measurement Level = Reading Level + Factor(Probe+Cable-Amp).</p>												
Remark												

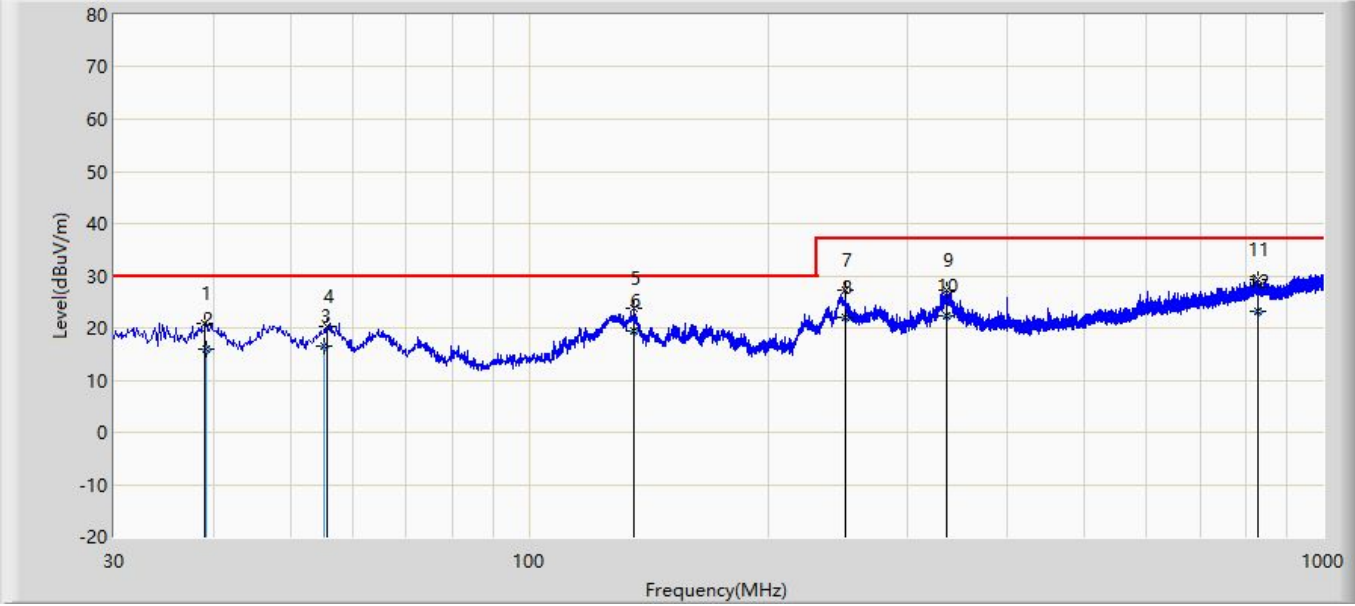
Measurement data		<input checked="" type="checkbox"/>		Horizontal		<input type="checkbox"/>		Vertical				
Operating mode / voltage / frequency used during the test				Mode 3/ PV: 480 Vdc, Battery: 500 Vdc, AC mains: 400 Vac								
Site: AC1				Time: 2022/05/24								
Limit: EN IEC 61000-6-3_RE (10m)				Margin: 0								
Probe: VULB9168_01099(30-1000MHz)				Polarity: Horizontal								
EUT: Storage Inverter				Power: PV: 480 Vdc, Battery: 500 Vdc, AC mains: 400 Vac								
Note: Mode 3												
												
No	Mark	Frequency (MHz)	Measure Level (dBuV/m)	Reading Level (dBuV)	Over Limit (dB)	Limit (dBuV/m)	Probe (dB/m)	Cable (dB)	Amp (dB)	Ant Pos (cm)	Table Pos (deg)	Type
1		39.176	15.999	23.600	-14.001	30.000	12.880	1.120	21.601	123	324	QP
2		55.156	16.572	23.400	-13.428	30.000	13.452	1.348	21.628	189	279	QP
3		135.654	19.367	26.500	-10.633	30.000	12.279	2.210	21.622	354	189	QP
4		250.654	22.002	28.500	-14.998	37.000	11.792	3.129	21.419	216	328	QP
5		336.163	22.231	25.400	-14.769	37.000	14.356	3.708	21.234	165	346	QP
6		828.565	23.162	13.500	-13.838	37.000	23.339	6.347	20.023	165	324	QP
<p>Note:</p> <p>1. " * ", means this data is the worst emission level.</p> <p>2. Measurement Level = Reading Level + Factor(Probe+Cable-Amp).</p>												
Remark												

Measurement data		<input type="checkbox"/>	Horizontal		<input checked="" type="checkbox"/>	Vertical						
Operating mode / voltage / frequency used during the test				Mode 3/ PV: 480 Vdc, Battery: 500 Vdc, AC mains: 400 Vac								
Site: AC1				Time: 2022/05/24								
Limit: EN IEC 61000-6-3_RE (10m)				Margin: 0								
Probe: VULB9168_01100(30-1000MHz)				Polarity: Vertical								
EUT: Storage Inverter				Power: PV: 480 Vdc, Battery: 500 Vdc, AC mains: 400 Vac								
Note: Mode 3												
												
No	Mark	Frequency (MHz)	Measure Level (dBuV/m)	Reading Level (dBuV)	Over Limit (dB)	Limit (dBuV/m)	Probe (dB/m)	Cable (dB)	Amp (dB)	Ant Pos (cm)	Table Pos (deg)	Type
1		31.354	18.141	37.500	-11.859	30.000	12.568	1.111	33.038	165	34	QP
2		81.564	17.526	40.500	-12.474	30.000	8.697	1.867	33.538	165	354	QP
3	*	130.004	28.078	47.800	-1.922	30.000	11.451	2.417	33.590	100	203	QP
4		247.684	24.120	42.500	-12.880	37.000	11.515	3.470	33.365	234	324	QP
5		349.683	24.810	39.500	-12.190	37.000	14.243	4.227	33.161	152	244	QP
6		913.354	19.539	20.400	-17.461	37.000	23.007	7.489	31.357	189	354	QP
<p>Note:</p> <p>1. " * ", means this data is the worst emission level.</p> <p>2. Measurement Level = Reading Level + Factor(Probe+Cable-Amp).</p>												
Remark												

4.5 Radiated electromagnetic disturbances (Above 1 GHz)	VERDICT: N/A
--	---------------------

Standard	EN IEC 61000-6-3		
Basic standard(s)	EN 55016-2-3		
Test method	Antenna method according to EN 55016-2-3 standard.		
Required highest frequency for radiated measurement			
	Highest internal frequency [f _x]	Highest measured frequency	
<input checked="" type="checkbox"/>	f _x ≤ 108 MHz	1 GHz	
<input type="checkbox"/>	108 MHz < f _x ≤ 500 MHz	2 GHz	
<input type="checkbox"/>	500 MHz < f _x ≤ 1 GHz	5 GHz	
<input type="checkbox"/>	f _x ≥ 1 GHz	5x f _x or up to 6 GHz	

Limits

Frequency [GHz]	Limit: PK@3m.[dB(μV/m) ¹⁾	Limit: AV@3m.[dB(μV/m) ¹⁾	IF BW	Detector
1 - 3	70	50	1 MHz	PK, CAV
3 - 6	74	54	1 MHz	PK, CAV

¹⁾ At the transition frequency, the lower limit applies.

Performed measurements

Port under test	Enclosure		
Voltage – Mains [V]	---		
Frequency – Mains [Hz]	---		
Test method applied	<input type="checkbox"/>	Absorber-lined OATS or SAC with measurement distance [m]: 3 m.	
	<input type="checkbox"/>	Absorber-lined OATS or SAC with measurement distance [m]: 1 m.	
Test setup	<input type="checkbox"/>	Equipment on a table of 80 cm height	
	<input type="checkbox"/>	Equipment on the floor (insulated from ground plane)	
	<input type="checkbox"/>	Other:	
Refer to the Annex 2 for test setup photo(s).			
Operating mode(s) used	---		
Remark	---		

See next page.

Measurement data	<input type="checkbox"/>	Horizontal	<input type="checkbox"/>	Vertical
Operating mode / voltage / frequency used during the test				
The highest internal frequency[f _x] of EUT ≤ 108 MHz, so it needs not to perform the test item.				
Remark				

4.6 Discontinuous disturbance (Clicks) on AC power leads	VERDICT: N/A
---	---------------------

Standard	EN 55014-1		
Frequency [MHz]	Limit: QP [dB(μV)]	IF BW	Detector
0,15	66	9 KHz	QP
0,50	56	9 KHz	QP
1,40	56	9 KHz	QP
30,0	60	9 KHz	QP

Performed measurements

Scan range (0,9 - 1,1 U_N)	<input type="checkbox"/>	198 – 264 V _{AC}	<input type="checkbox"/>	207 – 253 V _{AC}	<input type="checkbox"/>	V _{AC}
Voltage – Mains [V]						
Frequency – Mains [Hz]						
Test method applied	<input type="checkbox"/>	Artificial mains network				
	<input type="checkbox"/>	Voltage probe				
Test setup	<input type="checkbox"/>	Table top	<input type="checkbox"/>	Floor standing		
	<input type="checkbox"/>	Other:				
	Refer to the Annex 2 for test setup photo(s).					
Operating mode(s) used	Exemptions from click measurements applicable (clause 4.2.3).					
Remark	---					

Reason for not performing the test	<input type="checkbox"/>	The amplitudes of the observed disturbances were all below the limit for continuous disturbance, these are not considered to be clicks.
------------------------------------	--------------------------	---

Measurement results	<input type="checkbox"/>	Neutral	<input type="checkbox"/>	Line 1	<input type="checkbox"/>	Line 2	<input type="checkbox"/>	Line 3
---------------------	--------------------------	---------	--------------------------	--------	--------------------------	--------	--------------------------	--------

Frequency (MHz)	First Measurement: Determination of the limit L_q – Quasi-peak							
	Limit L (dBμV)	Number of short clicks	Number of long clicks	Number of clicks – N_1	Time of meas. (min.)	Click rate N	Increased limit (dB)	Increased Limit L_q
0,15	66							
0,5	56							
1,4	56							
30	60							

<input type="checkbox"/>	The calculated click rate N is not more than 5 times per minute and all the clicks are classified as short ($t \leq 10$ ms). Thus, the EUT is deemed to comply with the limits without any further measurement at an increased limit.
--------------------------	--

Frequency (MHz)	Second measurement with Limit = L_q (Upper quartile method):			
	Limit L_q (dBμV)	Number of clicks – N_2	Number of authorized clicks $N_2 \leq N_1/4$	Verdict
0,15				
0,5				
1,4				
30				

Supplementary information:

4.7 Harmonic current emissions	VERDICT: PASS
---------------------------------------	----------------------

Standard	EN IEC 61000-6-3		
Basic standard	EN IEC 61000-3-2&EN 61000-3-12		
Exclusions (For these categories of equipment, limits are not specified in the EN 61000-3-2 standard)	<input type="checkbox"/>		Arc welding equipment intended for professional use.
	<input type="checkbox"/>		System(s) with nominal voltage(s) less than 220 V _{AC} (line-to-neutral).
	<input type="checkbox"/>		Equipment with rated power of ≤ 75 W (other than lighting equipment).
	<input type="checkbox"/>		Professional equipment with total rated power > 1 kW.
	<input type="checkbox"/>		Symmetrically controlled heating elements with a rated power ≥ 200 W.
	<input type="checkbox"/>		Independent dimmers for incandescent lamps with rated power ≤ 1 kW.

Classification ($I_{input} \leq 16A$)			
<input checked="" type="checkbox"/>	Class A	All apparatus not classified as Class B, C or D	
<input type="checkbox"/>	Class B	Portable tools	
<input type="checkbox"/>	Class C	<input type="checkbox"/>	Lighting equipment with active input power > 25 W
		<input type="checkbox"/>	Lighting equipment with active input power ≤ 25 W (First requirement, Table 3 column 2)
		<input type="checkbox"/>	Lighting equipment with active input power ≤ 25 W (Second requirement)
<input type="checkbox"/>	Class D	Personal computers, television receivers	

Classification ($16A \leq I_{input} < 75A$)		
<input type="checkbox"/>	Table 2	other than balanced three-phase equipment
<input checked="" type="checkbox"/>	Table 3	balanced three-phase equipment
<input type="checkbox"/>	Table 4	balanced three-phase equipment under specified conditions
<input type="checkbox"/>	Table 5	balanced three-phase equipment under specified conditions

Performed measurements

Port under test	AC mains port					
Voltage – Mains [V]	400 Vac					
Frequency – Mains [Hz]	50 Hz					
Observation period	<input type="checkbox"/>	6.5 min.	<input type="checkbox"/>	2.5 min.	<input checked="" type="checkbox"/>	Other: 3 min.
Version of measurement instrument standard used EN / IEC61000-4-7 (Cl. 7)	<input checked="" type="checkbox"/>	EN 61000-4-7:2002 + AM1:2009 (IEC 61000-4-7:2002+AM1:2008)				
	<input type="checkbox"/>	EN 61000-4-7:1991				
Control principle used in the EUT	<input checked="" type="checkbox"/>	Comply with the requirements of the Clause 6.2 (EN / IEC 61000-3-2).				
	<input checked="" type="checkbox"/>	Comply with the requirements of the Clause 5.1 (EN / IEC 61000-3-12).				
	<input type="checkbox"/>	Not comply with the requirements of the Clause 6.2 (EN / IEC 61000-3-2).				
	<input type="checkbox"/>	Not comply with the requirements of the Clause 5.1 (EN / IEC 61000-3-12).				
Operating mode(s) used	Mode 4, 5					
Remark	---					

Measurement data	Port under test	AC mains port – Line 1
-------------------------	-----------------	------------------------

Operating mode / voltage / frequency used during the test	Mode 4/ Input: 480 Vdc, Output: 400 Vac
---	---

Test Result: Pass

Source qualification: Normal

Current & voltage waveforms

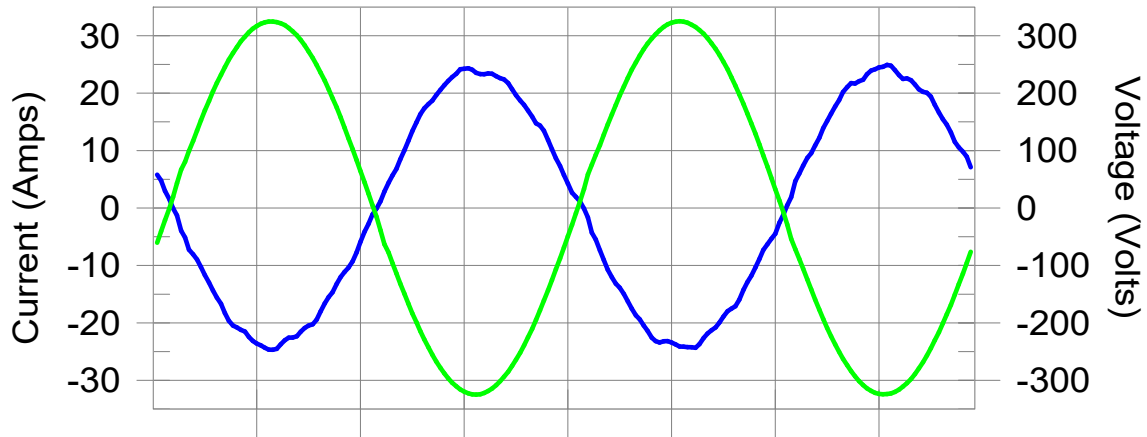

Harmonics and Class 3 limit line

European Limits

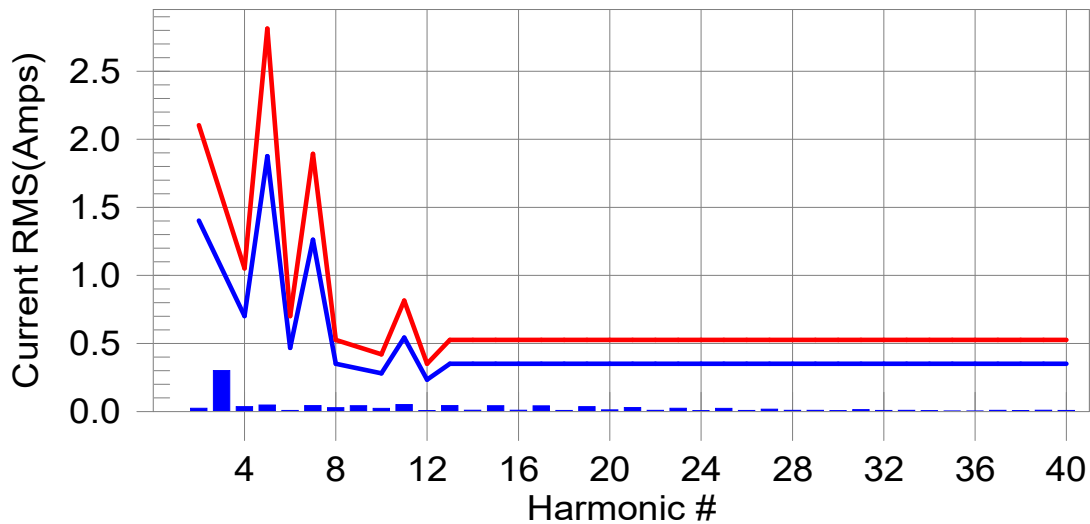

Test result: Pass

Remark	
--------	--

Measurement data				Port under test	AC mains port – Line 1			
Operating mode / voltage / frequency used during the test				Mode 4/ Input: 480 Vdc, Output: 400 Vac				
Test Result: Pass		Measured Iref: 17.528(Amps)		Source: Normal				
THC/Iref (%): 1.7		Limit (%): 13.0		PWHC/Iref (%): 0.0		PWHC Limit (%): 22.0		
Highest parameter values during test:								
V_RMS (Volts): 229.93				Frequency (Hz): 50.00				
I_Peak (Amps): 26.213				I_RMS (Amps): 17.566				
I_Fund (Amps): 17.519(avg)				Crest Factor: 1.500				
Power (Watts): -4062				Power Factor: -0.999				
Harm#	Harms(avg)	100%Limit	%of Limit	Harms(max)	150%Limit	%of Limit	Status	
2	0.024	1.402	1.7	0.036	2.103	1.7	Pass	
3	0.301	N/A	N/A	0.308	N/A	N/A	N/A	
4	0.036	0.701	5.1	0.048	1.052	4.5	Pass	
5	0.048	1.876	2.6	0.053	2.813	1.9	Pass	
6	0.008	0.467	1.8	0.020	0.701	2.9	Pass	
7	0.044	1.262	3.5	0.049	1.893	2.6	Pass	
8	0.028	0.351	8.0	0.034	0.526	6.5	Pass	
9	0.043	N/A	N/A	0.049	N/A	N/A	N/A	
10	0.023	0.280	8.3	0.028	0.421	6.7	Pass	
11	0.051	0.543	9.5	0.059	0.815	7.3	Pass	
12	0.007	0.234	2.9	0.009	0.351	2.6	Pass	
13	0.044	0.351	12.6	0.050	0.526	9.6	Pass	
14	0.010	N/A	N/A	0.018	N/A	N/A	N/A	
15	0.043	N/A	N/A	0.048	N/A	N/A	N/A	
16	0.010	N/A	N/A	0.017	N/A	N/A	N/A	
17	0.042	N/A	N/A	0.047	N/A	N/A	N/A	
18	0.008	N/A	N/A	0.012	N/A	N/A	N/A	
19	0.036	N/A	N/A	0.043	N/A	N/A	N/A	
20	0.012	N/A	N/A	0.017	N/A	N/A	N/A	
21	0.029	N/A	N/A	0.033	N/A	N/A	N/A	
22	0.009	N/A	N/A	0.013	N/A	N/A	N/A	
23	0.024	N/A	N/A	0.028	N/A	N/A	N/A	
24	0.006	N/A	N/A	0.009	N/A	N/A	N/A	
25	0.023	N/A	N/A	0.027	N/A	N/A	N/A	
26	0.008	N/A	N/A	0.016	N/A	N/A	N/A	
27	0.017	N/A	N/A	0.019	N/A	N/A	N/A	
28	0.009	N/A	N/A	0.016	N/A	N/A	N/A	
29	0.009	N/A	N/A	0.011	N/A	N/A	N/A	
30	0.006	N/A	N/A	0.010	N/A	N/A	N/A	
31	0.014	N/A	N/A	0.017	N/A	N/A	N/A	
32	0.008	N/A	N/A	0.012	N/A	N/A	N/A	
33	0.009	N/A	N/A	0.012	N/A	N/A	N/A	
34	0.006	N/A	N/A	0.010	N/A	N/A	N/A	
35	0.004	N/A	N/A	0.006	N/A	N/A	N/A	
36	0.004	N/A	N/A	0.007	N/A	N/A	N/A	
37	0.009	N/A	N/A	0.013	N/A	N/A	N/A	
38	0.007	N/A	N/A	0.014	N/A	N/A	N/A	
39	0.010	N/A	N/A	0.012	N/A	N/A	N/A	
40	0.008	N/A	N/A	0.013	N/A	N/A	N/A	
1. Dynamic limits were applied for this test. The highest harmonics values in the above table may not occur at the same window as the maximum harmonics/limit ratio. 2. According to EN 61000-3-2 paragraph 7 the note 1 and 2 are valid for all applications having an active input power >75W. Others the result should be pass.								
Remark								

Measurement data	Port under test	AC mains port – Line 2
-------------------------	-----------------	------------------------

Operating mode / voltage / frequency used during the test	Mode 4/ Input: 480 Vdc, Output: 400 Vac
---	---

Test Result: Pass

Source qualification: Normal

Current & voltage waveforms

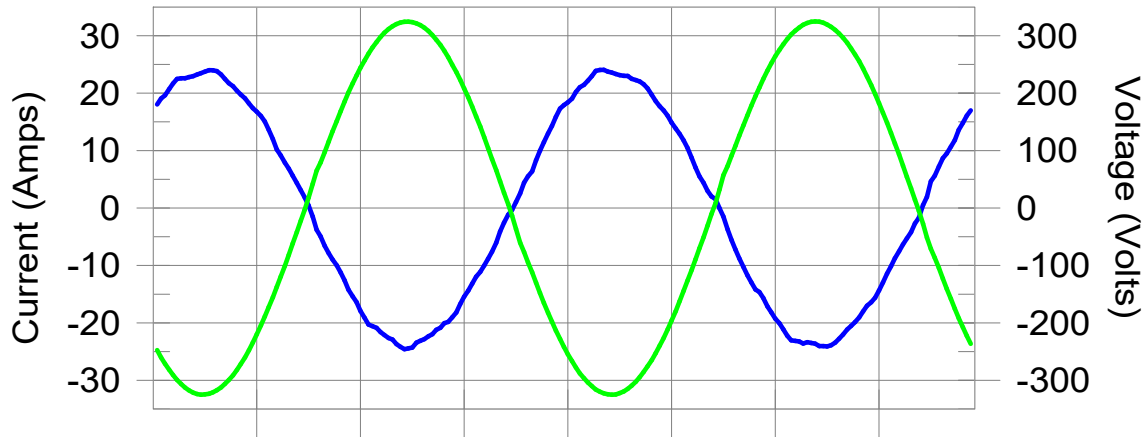

Harmonics and Class 3 limit line

European Limits

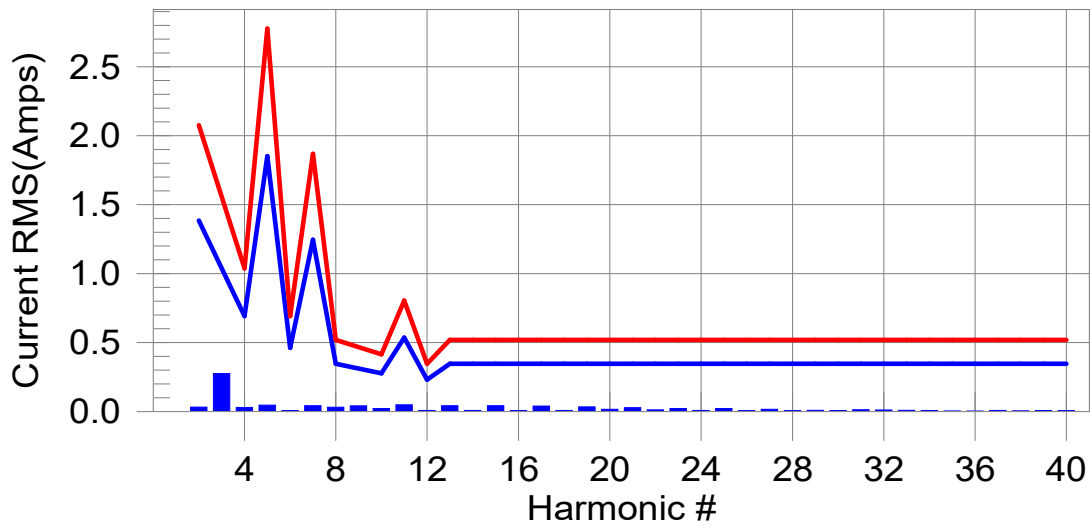

Test result: Pass

Remark	
--------	--

Measurement data				Port under test	AC mains port – Line 2			
Operating mode / voltage / frequency used during the test				Mode 4/ Input: 480 Vdc, Output: 400 Vac				
Test Result: Pass		Measured Iref: 17.299(Amps)		Source: Normal				
THC/Iref (%): 1.6		Limit (%): 13.0		PWHC/Iref (%): 0.0		PWHC Limit (%): 22.0		
Highest parameter values during test:								
V_RMS (Volts): 229.86				Frequency (Hz): 50.00				
I_Peak (Amps): 26.064				I_RMS (Amps): 17.339				
I_Fund (Amps): 17.291(avg)				Crest Factor: 1.511				
Power (Watts): -4008				Power Factor: -0.999				
Harm#	Harms(avg)	100%Limit	%of Limit	Harms(max)	150%Limit	%of Limit	Status	
2	0.032	1.384	2.3	0.048	2.076	2.3	Pass	
3	0.301	N/A	N/A	0.282	N/A	N/A	N/A	
4	0.030	0.692	4.3	0.039	1.038	3.8	Pass	
5	0.046	1.851	2.5	0.050	2.776	1.8	Pass	
6	0.007	0.461	1.6	0.012	0.692	1.7	Pass	
7	0.042	1.246	3.3	0.045	1.868	2.4	Pass	
8	0.031	0.346	8.9	0.036	0.519	7.0	Pass	
9	0.043	N/A	N/A	0.046	N/A	N/A	N/A	
10	0.022	0.277	8.1	0.027	0.415	6.5	Pass	
11	0.049	0.536	9.1	0.053	0.804	6.6	Pass	
12	0.008	0.231	3.3	0.011	0.346	3.2	Pass	
13	0.042	0.346	12.2	0.046	0.519	8.8	Pass	
14	0.008	N/A	N/A	0.012	N/A	N/A	N/A	
15	0.042	N/A	N/A	0.045	N/A	N/A	N/A	
16	0.007	N/A	N/A	0.010	N/A	N/A	N/A	
17	0.040	N/A	N/A	0.042	N/A	N/A	N/A	
18	0.008	N/A	N/A	0.013	N/A	N/A	N/A	
19	0.034	N/A	N/A	0.036	N/A	N/A	N/A	
20	0.016	N/A	N/A	0.025	N/A	N/A	N/A	
21	0.028	N/A	N/A	0.030	N/A	N/A	N/A	
22	0.012	N/A	N/A	0.016	N/A	N/A	N/A	
23	0.022	N/A	N/A	0.023	N/A	N/A	N/A	
24	0.008	N/A	N/A	0.014	N/A	N/A	N/A	
25	0.022	N/A	N/A	0.023	N/A	N/A	N/A	
26	0.006	N/A	N/A	0.012	N/A	N/A	N/A	
27	0.016	N/A	N/A	0.018	N/A	N/A	N/A	
28	0.006	N/A	N/A	0.010	N/A	N/A	N/A	
29	0.009	N/A	N/A	0.011	N/A	N/A	N/A	
30	0.007	N/A	N/A	0.016	N/A	N/A	N/A	
31	0.013	N/A	N/A	0.016	N/A	N/A	N/A	
32	0.011	N/A	N/A	0.016	N/A	N/A	N/A	
33	0.009	N/A	N/A	0.012	N/A	N/A	N/A	
34	0.007	N/A	N/A	0.010	N/A	N/A	N/A	
35	0.004	N/A	N/A	0.005	N/A	N/A	N/A	
36	0.003	N/A	N/A	0.005	N/A	N/A	N/A	
37	0.008	N/A	N/A	0.016	N/A	N/A	N/A	
38	0.005	N/A	N/A	0.008	N/A	N/A	N/A	
39	0.007	N/A	N/A	0.009	N/A	N/A	N/A	
40	0.006	N/A	N/A	0.009	N/A	N/A	N/A	
1. Dynamic limits were applied for this test. The highest harmonics values in the above table may not occur at the same window as the maximum harmonics/limit ratio. 2. According to EN 61000-3-2 paragraph 7 the note 1 and 2 are valid for all applications having an active input power >75W. Others the result should be pass.								
Remark								

Measurement data	Port under test	AC mains port – Line 3
-------------------------	-----------------	------------------------

Operating mode / voltage / frequency used during the test	Mode 4/ Input: 480 Vdc, Output: 400 Vac
---	---

Test Result: Pass

Source qualification: Normal

Current & voltage waveforms

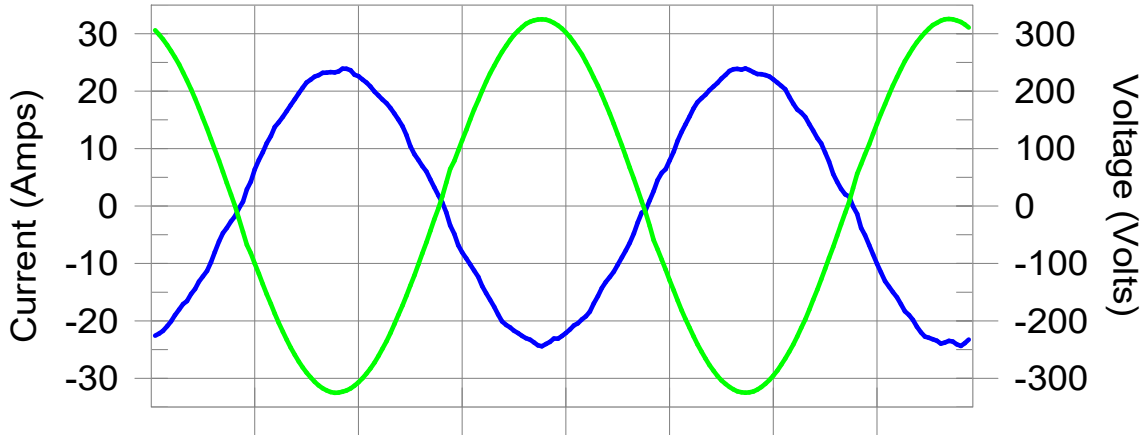

Harmonics and Class 3 limit line

European Limits

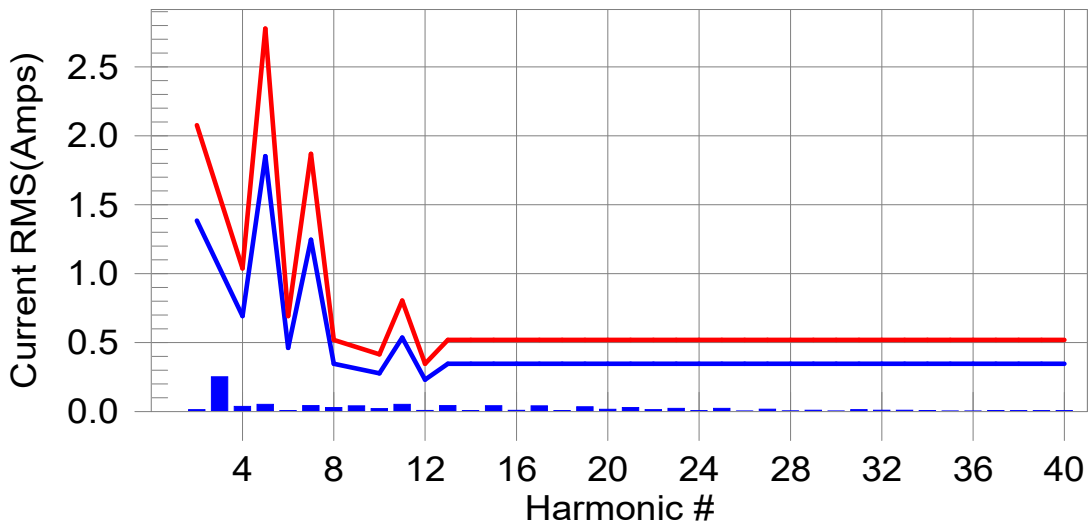

Test result: Pass

Remark	
--------	--

Measurement data		Port under test	AC mains port – Line 3				
Operating mode / voltage / frequency used during the test		Mode 4/ Input: 480 Vdc, Output: 400 Vac					
Test Result: Pass THC/Iref (%): 1.5 Limit (%): 13.0 PWHC/Iref (%): 0.0		Measured Iref: 17.305(Amps) PWHC Limit (%): 22.0		Source: Normal			
Highest parameter values during test: V_RMS (Volts): 230.08 Frequency (Hz): 50.00 I_Peak (Amps): 25.880 I_RMS (Amps): 17.340 I_Fund (Amps): 17.297(avg) Crest Factor: 1.499 Power (Watts): -4012 Power Factor: -0.999							
Harm#	Harms(avg)	100%Limit	%of Limit	Harms(max)	150%Limit	%of Limit	Status
2	0.014	1.384	1.0	0.025	2.077	1.2	Pass
3	0.301	N/A	N/A	0.259	N/A	N/A	N/A
4	0.037	0.692	5.3	0.046	1.038	4.4	Pass
5	0.052	1.852	2.8	0.056	2.777	2.0	Pass
6	0.007	0.461	1.5	0.011	0.692	1.5	Pass
7	0.043	1.246	3.4	0.047	1.869	2.5	Pass
8	0.029	0.346	8.5	0.035	0.519	6.7	Pass
9	0.043	N/A	N/A	0.052	N/A	N/A	N/A
10	0.021	0.277	7.7	0.028	0.415	6.8	Pass
11	0.052	0.536	9.6	0.056	0.805	6.9	Pass
12	0.008	0.231	3.5	0.012	0.346	3.5	Pass
13	0.043	0.346	12.5	0.048	0.519	9.2	Pass
14	0.007	N/A	N/A	0.016	N/A	N/A	N/A
15	0.042	N/A	N/A	0.047	N/A	N/A	N/A
16	0.009	N/A	N/A	0.013	N/A	N/A	N/A
17	0.041	N/A	N/A	0.045	N/A	N/A	N/A
18	0.007	N/A	N/A	0.010	N/A	N/A	N/A
19	0.035	N/A	N/A	0.038	N/A	N/A	N/A
20	0.016	N/A	N/A	0.025	N/A	N/A	N/A
21	0.029	N/A	N/A	0.031	N/A	N/A	N/A
22	0.014	N/A	N/A	0.026	N/A	N/A	N/A
23	0.023	N/A	N/A	0.026	N/A	N/A	N/A
24	0.006	N/A	N/A	0.009	N/A	N/A	N/A
25	0.023	N/A	N/A	0.025	N/A	N/A	N/A
26	0.004	N/A	N/A	0.008	N/A	N/A	N/A
27	0.017	N/A	N/A	0.019	N/A	N/A	N/A
28	0.005	N/A	N/A	0.009	N/A	N/A	N/A
29	0.010	N/A	N/A	0.012	N/A	N/A	N/A
30	0.004	N/A	N/A	0.005	N/A	N/A	N/A
31	0.014	N/A	N/A	0.017	N/A	N/A	N/A
32	0.010	N/A	N/A	0.014	N/A	N/A	N/A
33	0.010	N/A	N/A	0.012	N/A	N/A	N/A
34	0.007	N/A	N/A	0.011	N/A	N/A	N/A
35	0.004	N/A	N/A	0.007	N/A	N/A	N/A
36	0.004	N/A	N/A	0.005	N/A	N/A	N/A
37	0.007	N/A	N/A	0.010	N/A	N/A	N/A
38	0.006	N/A	N/A	0.009	N/A	N/A	N/A
39	0.006	N/A	N/A	0.008	N/A	N/A	N/A
40	0.006	N/A	N/A	0.010	N/A	N/A	N/A
1. Dynamic limits were applied for this test. The highest harmonics values in the above table may not occur at the same window as the maximum harmonics/limit ratio. 2. According to EN 61000-3-2 paragraph 7 the note 1 and 2 are valid for all applications having an active input power >75W. Others the result should be pass.							
Remark							

Measurement data	Port under test	AC mains port – Line 1
-------------------------	-----------------	------------------------

Operating mode / voltage / frequency used during the test	Mode 5/ Input: 480 Vdc, Output: 400 Vac
---	---

Test Result: Pass

Source qualification: Normal

Current & voltage waveforms

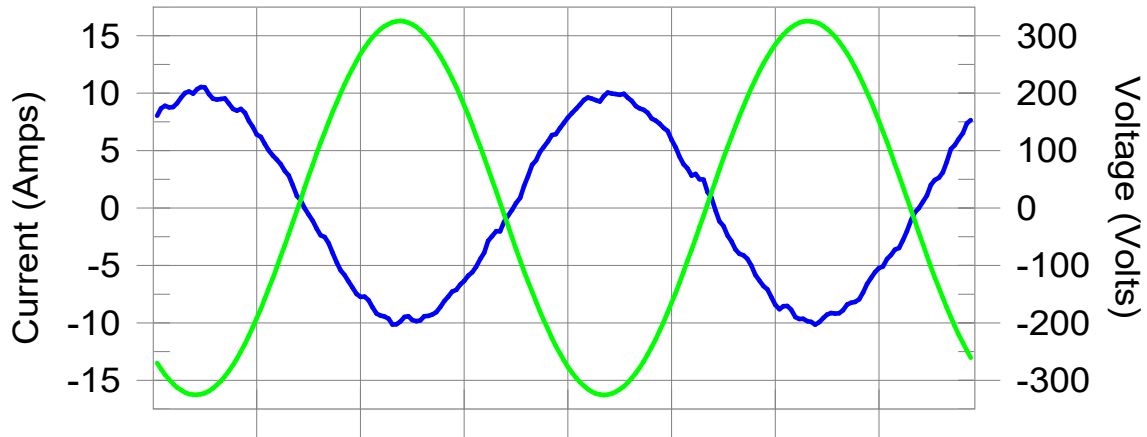

Harmonics and Class A limit line

European Limits

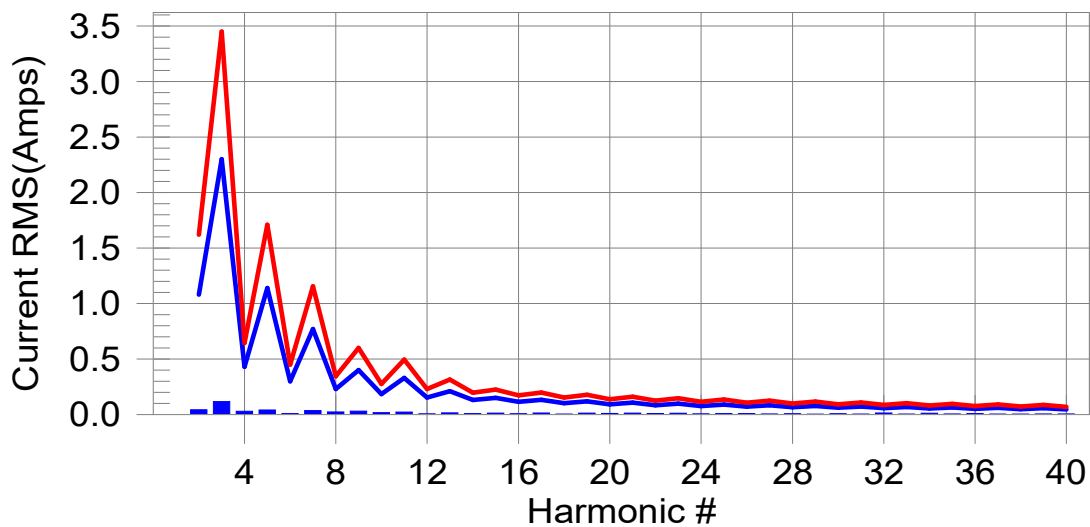

Test result: Pass

Remark	
--------	--

Measurement data				Port under test	AC mains port – Line 1			
Operating mode / voltage / frequency used during the test				Mode 5/ Input: 480 Vdc, Output: 400 Vac				
Test Result: Pass		Source qualification: Normal						
THC(A): 0.155	I-THD(%): 2.1	POHC(A): 0.022	POHC Limit(A): 0.251					
Highest parameter values during test:								
V_RMS (Volts):	230.292	Frequency(Hz):	50.00					
I_Peak (Amps):	11.812	I_RMS (Amps):	7.540					
I_Fund (Amps):	7.415	Crest Factor:	1.606					
Power (Watts):	-1695.3	Power Factor:	-0.992					
Harm#	Harms(avg)	100%Limit	%of Limit	Harms(max)	150%Limit	%of Limit	Status	
2	0.043	1.080	4.0	0.064	1.620	4.0	Pass	
3	0.117	2.300	5.1	0.123	3.450	3.6	Pass	
4	0.029	0.430	6.8	0.037	0.645	5.8	Pass	
5	0.041	1.140	3.6	0.043	1.710	2.5	Pass	
6	0.008	0.300	2.6	0.010	0.450	2.2	Pass	
7	0.036	0.770	4.7	0.039	1.155	3.4	Pass	
8	0.023	0.230	10.1	0.030	0.345	8.8	Pass	
9	0.031	0.400	7.7	0.033	0.600	5.5	Pass	
10	0.017	0.184	9.4	0.023	0.276	8.3	Pass	
11	0.022	0.330	6.7	0.026	0.495	5.2	Pass	
12	0.005	0.153	3.5	0.008	0.230	3.6	Pass	
13	0.015	0.210	7.0	0.017	0.315	5.5	Pass	
14	0.007	0.131	5.7	0.011	0.197	5.6	Pass	
15	0.013	0.150	8.7	0.015	0.225	6.8	Pass	
16	0.007	0.115	6.2	0.011	0.173	6.1	Pass	
17	0.014	0.132	10.6	0.016	0.198	8.3	Pass	
18	0.003	0.102	N/A	0.005	0.153	N/A	Pass	
19	0.013	0.118	10.7	0.015	0.178	8.4	Pass	
20	0.010	0.092	10.8	0.015	0.138	11.0	Pass	
21	0.013	0.107	12.3	0.016	0.161	10.1	Pass	
22	0.009	0.084	10.9	0.016	0.125	13.0	Pass	
23	0.011	0.098	11.8	0.013	0.147	9.2	Pass	
24	0.006	0.077	7.6	0.010	0.115	8.6	Pass	
25	0.007	0.090	8.3	0.010	0.135	7.4	Pass	
26	0.007	0.071	10.5	0.012	0.107	11.2	Pass	
27	0.005	0.083	N/A	0.007	0.125	N/A	Pass	
28	0.007	0.066	10.1	0.014	0.099	13.9	Pass	
29	0.003	0.078	N/A	0.004	0.116	N/A	Pass	
30	0.007	0.061	11.3	0.011	0.092	12.1	Pass	
31	0.003	0.073	N/A	0.006	0.109	N/A	Pass	
32	0.014	0.058	24.8	0.019	0.086	21.7	Pass	
33	0.003	0.068	N/A	0.006	0.102	N/A	Pass	
34	0.012	0.054	21.3	0.014	0.081	16.7	Pass	
35	0.004	0.064	N/A	0.007	0.096	N/A	Pass	
36	0.008	0.051	15.3	0.010	0.077	13.1	Pass	
37	0.004	0.061	N/A	0.007	0.091	N/A	Pass	
38	0.004	0.048	N/A	0.007	0.073	N/A	Pass	
39	0.005	0.058	N/A	0.008	0.087	N/A	Pass	
40	0.004	0.046	N/A	0.008	0.069	N/A	Pass	
<p>1. Dynamic limits were applied for this test. The highest harmonics values in the above table may not occur at the same window as the maximum harmonics/limit ratio.</p> <p>2. According to EN 61000-3-2 paragraph 7 the note 1 and 2 are valid for all applications having an active input power >75W. Others the result should be pass.</p>								
Remark								

Measurement data	Port under test	AC mains port – Line 2
-------------------------	-----------------	------------------------

Operating mode / voltage / frequency used during the test	Mode 5/ Input: 480 Vdc, Output: 400 Vac
---	---

Test Result: Pass

Source qualification: Normal

Current & voltage waveforms

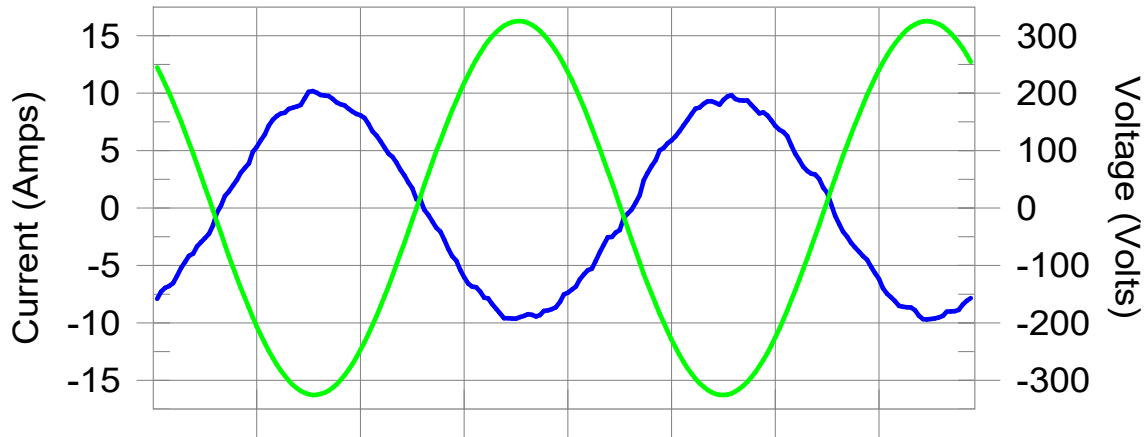

Harmonics and Class A limit line

European Limits

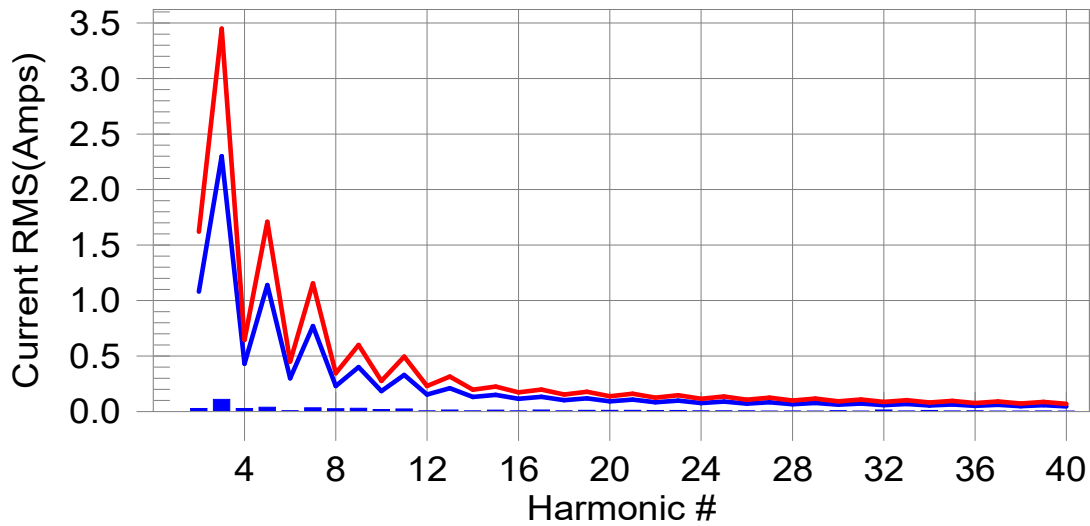

Test result: Pass

Remark	
--------	--

Measurement data				Port under test	AC mains port – Line 2			
Operating mode / voltage / frequency used during the test				Mode 5/ Input: 480 Vdc, Output: 400 Vac				
Test Result: Pass		Source qualification: Normal						
THC(A): 0.143		I-THD(%): 2.0		POHC(A): 0.019		POHC Limit(A): 0.251		
Highest parameter values during test:								
V_RMS (Volts): 230.309				Frequency(Hz): 50.00				
I_Peak (Amps): 11.914				I_RMS (Amps): 7.348				
I_Fund (Amps): 7.219				Crest Factor: 1.657				
Power (Watts): -1652.2				Power Factor: -0.993				
Harm#	Harms(avg)	100%Limit	%of Limit	Harms(max)	150%Limit	%of Limit	Status	
2	0.028	1.080	2.6	0.047	1.620	2.9	Pass	
3	0.110	2.300	4.8	0.116	3.450	3.4	Pass	
4	0.028	0.430	6.5	0.038	0.645	5.9	Pass	
5	0.039	1.140	3.4	0.041	1.710	2.4	Pass	
6	0.007	0.300	2.3	0.008	0.450	1.8	Pass	
7	0.033	0.770	4.3	0.036	1.155	3.1	Pass	
8	0.025	0.230	10.9	0.031	0.345	9.1	Pass	
9	0.029	0.400	7.3	0.033	0.600	5.5	Pass	
10	0.018	0.184	10.0	0.023	0.276	8.5	Pass	
11	0.023	0.330	6.9	0.025	0.495	5.0	Pass	
12	0.006	0.153	4.0	0.008	0.230	3.6	Pass	
13	0.014	0.210	6.6	0.016	0.315	5.1	Pass	
14	0.006	0.131	4.6	0.010	0.197	5.1	Pass	
15	0.013	0.150	8.6	0.014	0.225	6.4	Pass	
16	0.005	0.115	4.7	0.010	0.173	5.7	Pass	
17	0.014	0.132	10.8	0.016	0.198	7.9	Pass	
18	0.005	0.102	5.2	0.010	0.153	6.6	Pass	
19	0.011	0.118	9.2	0.012	0.178	6.9	Pass	
20	0.011	0.092	12.3	0.015	0.138	11.1	Pass	
21	0.011	0.107	10.3	0.013	0.161	7.9	Pass	
22	0.009	0.084	10.3	0.011	0.125	8.9	Pass	
23	0.010	0.098	10.1	0.011	0.147	7.7	Pass	
24	0.006	0.077	7.6	0.012	0.115	10.7	Pass	
25	0.005	0.090	6.0	0.007	0.135	5.0	Pass	
26	0.006	0.071	8.6	0.011	0.107	10.3	Pass	
27	0.003	0.083	N/A	0.005	0.125	N/A	Pass	
28	0.004	0.066	N/A	0.007	0.099	N/A	Pass	
29	0.003	0.078	N/A	0.005	0.116	N/A	Pass	
30	0.006	0.061	10.4	0.010	0.092	10.7	Pass	
31	0.004	0.073	N/A	0.006	0.109	N/A	Pass	
32	0.014	0.058	24.4	0.019	0.086	21.7	Pass	
33	0.004	0.068	N/A	0.007	0.102	N/A	Pass	
34	0.010	0.054	17.6	0.012	0.081	14.8	Pass	
35	0.005	0.064	N/A	0.008	0.096	N/A	Pass	
36	0.006	0.051	10.9	0.007	0.077	9.1	Pass	
37	0.004	0.061	N/A	0.006	0.091	N/A	Pass	
38	0.003	0.048	N/A	0.005	0.073	N/A	Pass	
39	0.005	0.058	N/A	0.007	0.087	N/A	Pass	
40	0.004	0.046	N/A	0.006	0.069	N/A	Pass	
<p>1. Dynamic limits were applied for this test. The highest harmonics values in the above table may not occur at the same window as the maximum harmonics/limit ratio.</p> <p>2. According to EN 61000-3-2 paragraph 7 the note 1 and 2 are valid for all applications having an active input power >75W. Others the result should be pass.</p>								
Remark								

Measurement data	Port under test	AC mains port – Line 3
-------------------------	-----------------	------------------------

Operating mode / voltage / frequency used during the test	Mode 5/ Input: 480 Vdc, Output: 400 Vac
---	---

Test Result: Pass

Source qualification: Normal

Current & voltage waveforms

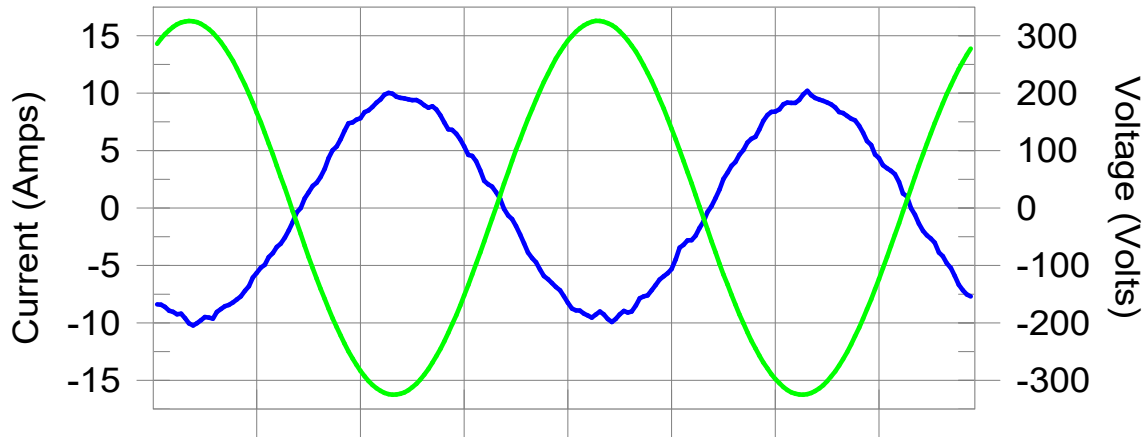

Harmonics and Class A limit line

European Limits

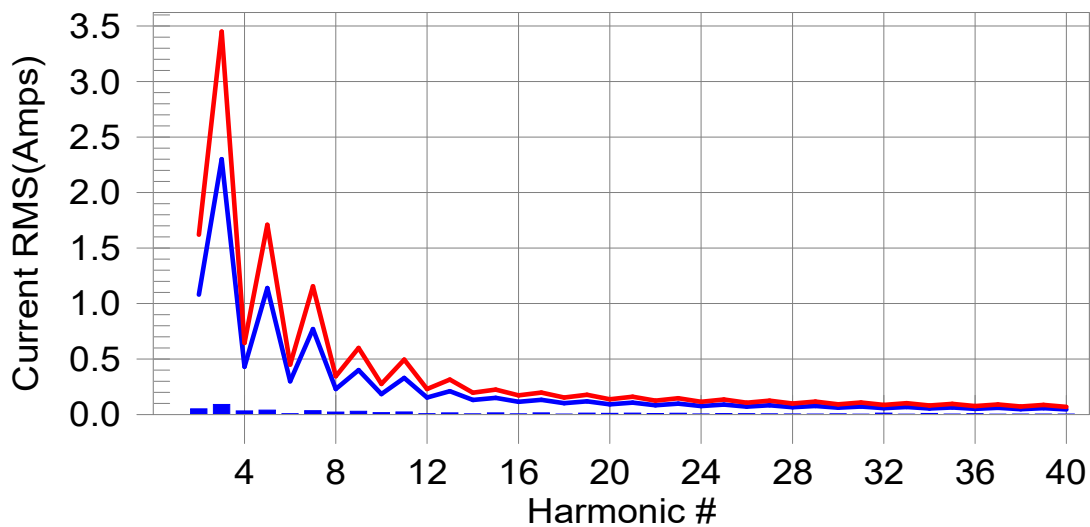

Test result: Pass

Remark	
--------	--

Measurement data				Port under test	AC mains port – Line 3			
Operating mode / voltage / frequency used during the test				Mode 5/ Input: 480 Vdc, Output: 400 Vac				
Test Result: Pass		Source qualification: Normal						
THC(A): 0.138		I-THD(%): 1.9		POHC(A): 0.021		POHC Limit(A): 0.251		
Highest parameter values during test:								
V_RMS (Volts): 230.223		Frequency(Hz): 50.00						
I_Peak (Amps): 11.623		I_RMS (Amps): 7.406						
I_Fund (Amps): 7.281		Crest Factor: 1.607						
Power (Watts): -1664.2		Power Factor: -0.992						
Harm#	Harms(avg)	100%Limit	%of Limit	Harms(max)	150%Limit	%of Limit	Status	
2	0.051	1.080	4.8	0.067	1.620	4.2	Pass	
3	0.091	2.300	4.0	0.097	3.450	2.8	Pass	
4	0.033	0.430	7.6	0.042	0.645	6.5	Pass	
5	0.040	1.140	3.5	0.043	1.710	2.5	Pass	
6	0.007	0.300	2.3	0.011	0.450	2.5	Pass	
7	0.034	0.770	4.5	0.036	1.155	3.2	Pass	
8	0.022	0.230	9.7	0.028	0.345	8.2	Pass	
9	0.030	0.400	7.4	0.032	0.600	5.4	Pass	
10	0.017	0.184	9.2	0.022	0.276	8.0	Pass	
11	0.023	0.330	7.0	0.025	0.495	5.1	Pass	
12	0.006	0.153	4.2	0.009	0.230	3.8	Pass	
13	0.015	0.210	7.3	0.018	0.315	5.7	Pass	
14	0.006	0.131	4.4	0.009	0.197	4.8	Pass	
15	0.015	0.150	9.8	0.020	0.225	9.0	Pass	
16	0.006	0.115	5.2	0.010	0.173	5.8	Pass	
17	0.015	0.132	11.2	0.018	0.198	8.9	Pass	
18	0.003	0.102	N/A	0.005	0.153	N/A	Pass	
19	0.013	0.118	10.6	0.016	0.178	9.3	Pass	
20	0.011	0.092	11.7	0.014	0.138	9.9	Pass	
21	0.013	0.107	12.0	0.018	0.161	10.9	Pass	
22	0.009	0.084	10.9	0.012	0.125	9.5	Pass	
23	0.012	0.098	11.9	0.014	0.147	9.3	Pass	
24	0.004	0.077	N/A	0.007	0.115	N/A	Pass	
25	0.008	0.090	8.6	0.010	0.135	7.5	Pass	
26	0.007	0.071	9.4	0.010	0.107	9.3	Pass	
27	0.005	0.083	6.5	0.008	0.125	6.3	Pass	
28	0.005	0.066	7.8	0.009	0.099	8.6	Pass	
29	0.003	0.078	N/A	0.005	0.116	N/A	Pass	
30	0.005	0.061	8.8	0.009	0.092	9.6	Pass	
31	0.003	0.073	N/A	0.004	0.109	N/A	Pass	
32	0.013	0.058	23.1	0.016	0.086	18.7	Pass	
33	0.003	0.068	N/A	0.005	0.102	N/A	Pass	
34	0.010	0.054	19.0	0.013	0.081	16.5	Pass	
35	0.004	0.064	N/A	0.006	0.096	N/A	Pass	
36	0.006	0.051	12.7	0.010	0.077	12.7	Pass	
37	0.003	0.061	N/A	0.006	0.091	N/A	Pass	
38	0.004	0.048	N/A	0.009	0.073	N/A	Pass	
39	0.004	0.058	N/A	0.007	0.087	N/A	Pass	
40	0.004	0.046	N/A	0.006	0.069	N/A	Pass	
1. Dynamic limits were applied for this test. The highest harmonics values in the above table may not occur at the same window as the maximum harmonics/limit ratio. 2. According to EN 61000-3-2 paragraph 7 the note 1 and 2 are valid for all applications having an active input power >75W. Others the result should be pass.								
Remark								

4.8 Voltage changes, voltage fluctuations and flicker	VERDICT: PASS
--	----------------------

Standard	EN IEC 61000-6-3
Basic standard	EN 61000-3-3

Limits

P _{ST} (Short term flicker)	<input checked="" type="checkbox"/>	≤ 1	<input type="checkbox"/>	Not Applicable
P _{LT} (Long term flicker)	<input checked="" type="checkbox"/>	≤ 0,65	<input type="checkbox"/>	Not Applicable
d _C (Relative Voltage change)	<input checked="" type="checkbox"/>	≤ 3,3%	<input type="checkbox"/>	Not Applicable
T _{max} (Maximum time duration)	<input checked="" type="checkbox"/>	≤ 500ms	<input type="checkbox"/>	Not Applicable
d _{MAX} (Max. voltage change)	<input checked="" type="checkbox"/>	≤ 4%	<input type="checkbox"/>	6%
	<input type="checkbox"/>	7%	<input type="checkbox"/>	Not Applicable
Supplemental information:				

Performed measurements

Reason for not performing the measurement(s)	<input type="checkbox"/>	Tests are not necessary because the EUT is unlikely to produce significant voltage fluctuations or flicker (clause 6.1).				
Port under test	AC mains port					
Voltage – Mains [V]	400 Vac					
Frequency – Mains [Hz]	50 Hz					
Test method	<input checked="" type="checkbox"/>	Flicker meter according EN / IEC 61000-4-15:2011				
	<input type="checkbox"/>	Simulation (Clause 4.2.3 of EN / IEC 61000-3-3)				
	<input type="checkbox"/>	Analytical method (Clause 4.2.4 of EN / IEC 61000-3-3)				
	<input type="checkbox"/>	Use of P _{st} = 1 curve (Clause 4.2.5 of EN / IEC 61000-3-3)				
Observation period	<input type="checkbox"/>	10 min.	<input checked="" type="checkbox"/>	120 min.	<input type="checkbox"/>	Other:
	<input type="checkbox"/>	24 times switching according to Annex B				
Operating mode(s) used	Mode 4, 5					
Remark	---					

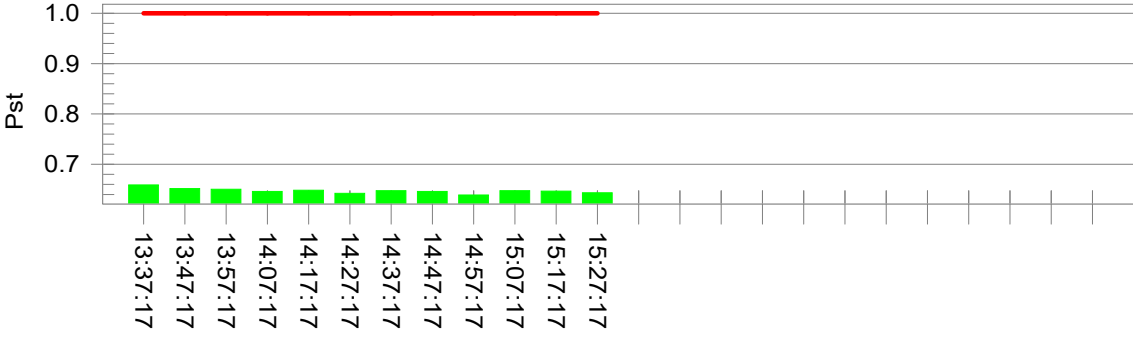
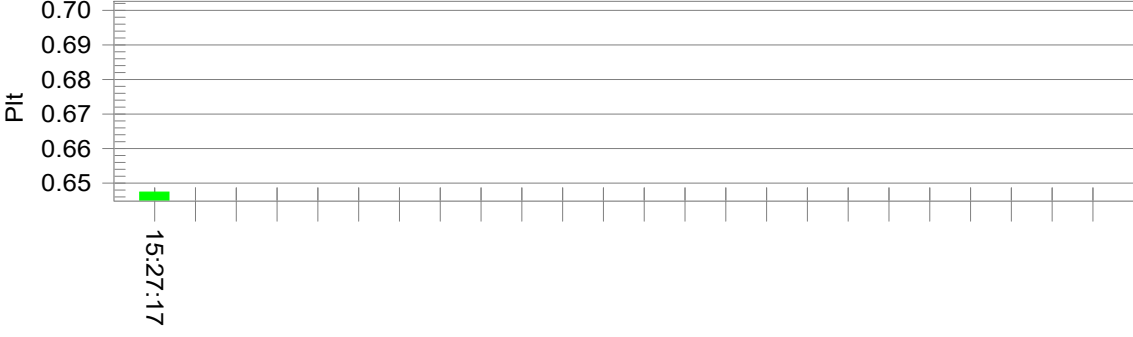

See next page.

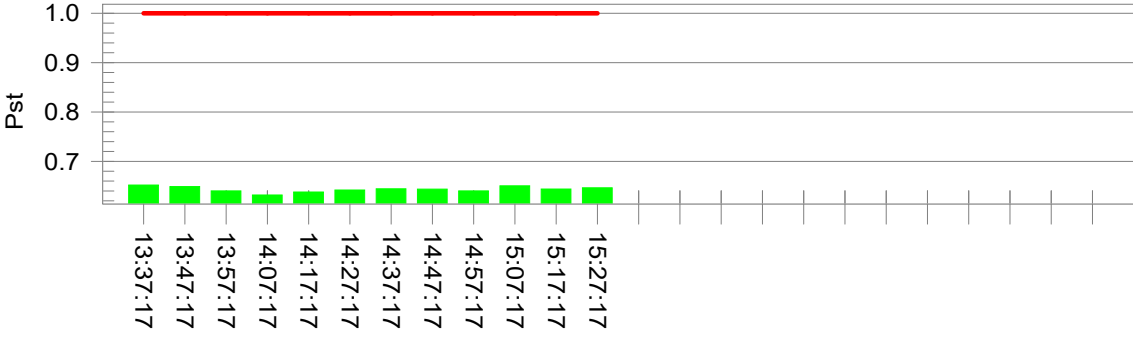
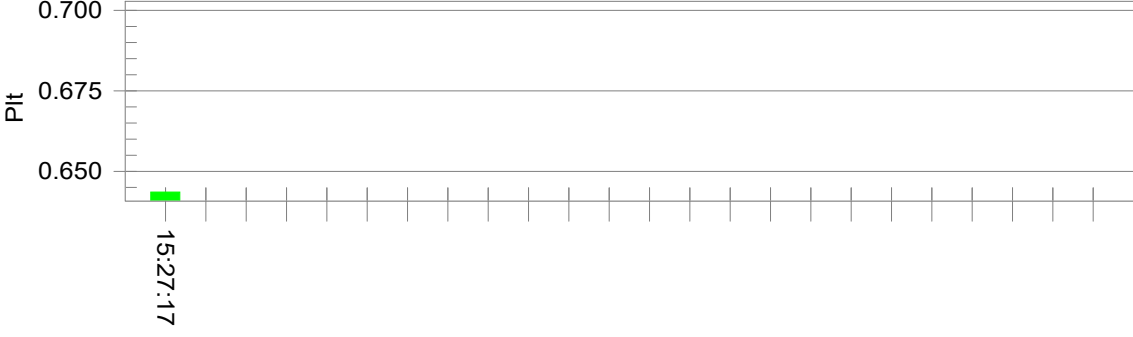
Measurement data	Port under test	AC mains port – Line 1																														
Operating mode used during the test	Mode 4/ Input: 480 Vdc, Output: 400 Vac																															
<p>Test Result: Pass Status: Test Completed</p> <p>Pst and limit line European Limits</p>  <p>Plt and limit line</p>  <p>Parameter values recorded during the test:</p> <table border="0"> <tr> <td>Vrms at the end of test (Volt):</td> <td>232.25</td> <td>Test limit (mS):</td> <td>500.0</td> <td>Pass</td> </tr> <tr> <td>T-max (mS):</td> <td>0.0</td> <td>Test limit (%):</td> <td>3.30</td> <td>Pass</td> </tr> <tr> <td>Highest dc (%):</td> <td>0.00</td> <td>Test limit (%):</td> <td>4.00</td> <td>Pass</td> </tr> <tr> <td>Highest dmax (%):</td> <td>1.26</td> <td>Test limit:</td> <td>1.000</td> <td>Pass</td> </tr> <tr> <td>Highest Pst (10 min. period):</td> <td>0.659</td> <td>Test limit:</td> <td>0.650</td> <td>Pass</td> </tr> <tr> <td>Highest Plt (2 hr. period):</td> <td>0.647</td> <td></td> <td></td> <td></td> </tr> </table>			Vrms at the end of test (Volt):	232.25	Test limit (mS):	500.0	Pass	T-max (mS):	0.0	Test limit (%):	3.30	Pass	Highest dc (%):	0.00	Test limit (%):	4.00	Pass	Highest dmax (%):	1.26	Test limit:	1.000	Pass	Highest Pst (10 min. period):	0.659	Test limit:	0.650	Pass	Highest Plt (2 hr. period):	0.647			
Vrms at the end of test (Volt):	232.25	Test limit (mS):	500.0	Pass																												
T-max (mS):	0.0	Test limit (%):	3.30	Pass																												
Highest dc (%):	0.00	Test limit (%):	4.00	Pass																												
Highest dmax (%):	1.26	Test limit:	1.000	Pass																												
Highest Pst (10 min. period):	0.659	Test limit:	0.650	Pass																												
Highest Plt (2 hr. period):	0.647																															
Remark																																

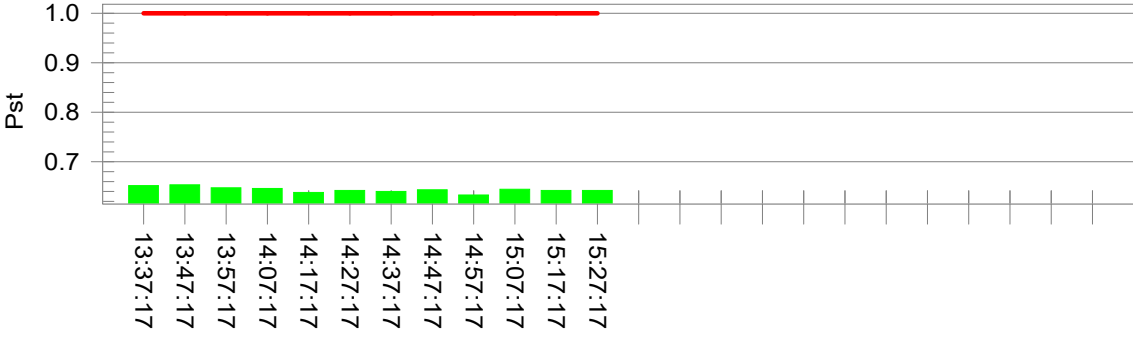
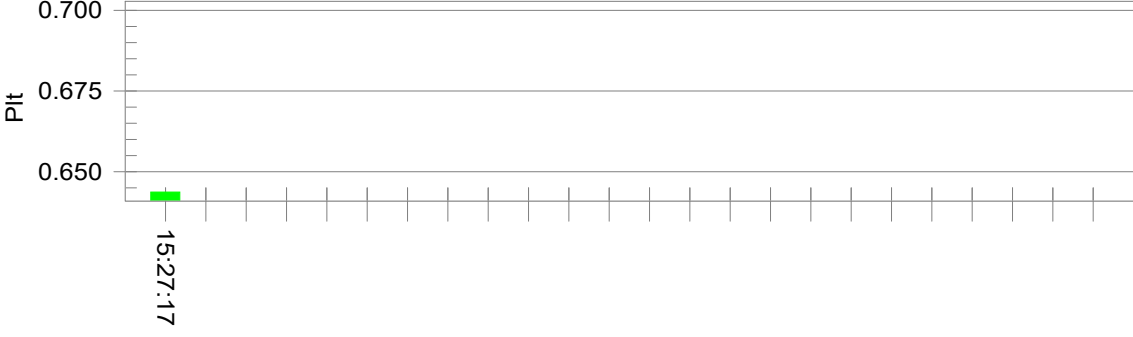
Measurement data	Port under test	AC mains port – Line 2																														
Operating mode used during the test	Mode 4/ Input: 480 Vdc, Output: 400 Vac																															
<p>Test Result: Pass Status: Test Completed</p> <p>Pst and limit line European Limits</p>  <p>Plt and limit line</p> 																																
<p>Parameter values recorded during the test:</p> <table border="0"> <tr> <td>Vrms at the end of test (Volt):</td> <td>232.93</td> <td>Test limit (mS):</td> <td>500.0</td> <td>Pass</td> </tr> <tr> <td>T-max (mS):</td> <td>0.0</td> <td>Test limit (%):</td> <td>3.30</td> <td>Pass</td> </tr> <tr> <td>Highest dc (%):</td> <td>0.00</td> <td>Test limit (%):</td> <td>4.00</td> <td>Pass</td> </tr> <tr> <td>Highest dmax (%):</td> <td>1.26</td> <td>Test limit:</td> <td>1.000</td> <td>Pass</td> </tr> <tr> <td>Highest Pst (10 min. period):</td> <td>0.652</td> <td>Test limit:</td> <td>0.650</td> <td>Pass</td> </tr> <tr> <td>Highest Plt (2 hr. period):</td> <td>0.644</td> <td></td> <td></td> <td></td> </tr> </table>			Vrms at the end of test (Volt):	232.93	Test limit (mS):	500.0	Pass	T-max (mS):	0.0	Test limit (%):	3.30	Pass	Highest dc (%):	0.00	Test limit (%):	4.00	Pass	Highest dmax (%):	1.26	Test limit:	1.000	Pass	Highest Pst (10 min. period):	0.652	Test limit:	0.650	Pass	Highest Plt (2 hr. period):	0.644			
Vrms at the end of test (Volt):	232.93	Test limit (mS):	500.0	Pass																												
T-max (mS):	0.0	Test limit (%):	3.30	Pass																												
Highest dc (%):	0.00	Test limit (%):	4.00	Pass																												
Highest dmax (%):	1.26	Test limit:	1.000	Pass																												
Highest Pst (10 min. period):	0.652	Test limit:	0.650	Pass																												
Highest Plt (2 hr. period):	0.644																															
Remark																																

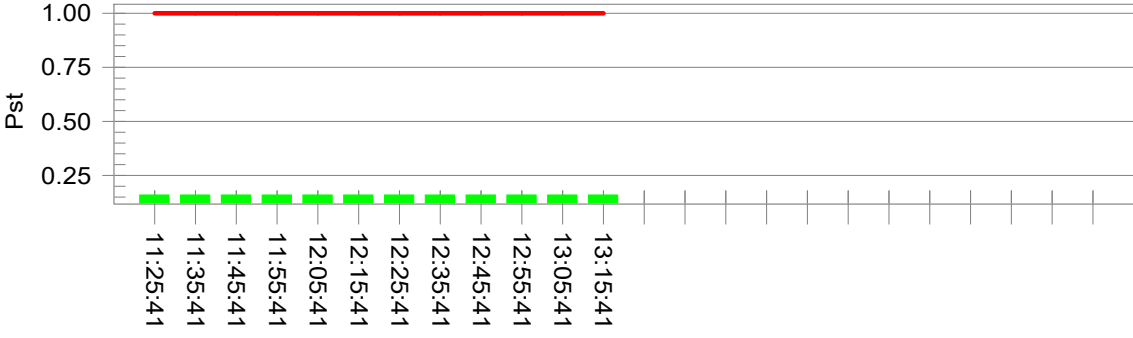
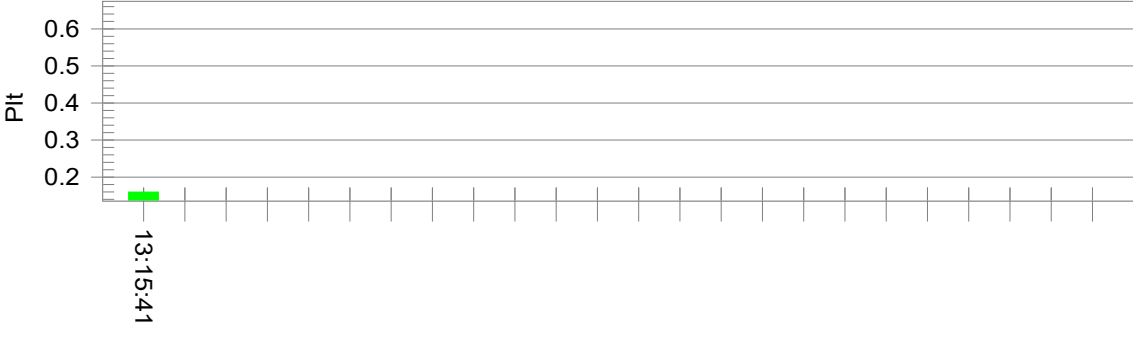
Measurement data	Port under test	AC mains port – Line 3																														
Operating mode used during the test	Mode 4/ Input: 480 Vdc, Output: 400 Vac																															
<p>Test Result: Pass Status: Test Completed</p> <p>Pst and limit line European Limits</p>  <p>Plt and limit line</p>  <p>Parameter values recorded during the test:</p> <table border="0"> <tr> <td>Vrms at the end of test (Volt):</td> <td>232.41</td> <td>Test limit (mS):</td> <td>500.0</td> <td>Pass</td> </tr> <tr> <td>T-max (mS):</td> <td>0.0</td> <td>Test limit (%):</td> <td>3.30</td> <td>Pass</td> </tr> <tr> <td>Highest dc (%):</td> <td>0.00</td> <td>Test limit (%):</td> <td>4.00</td> <td>Pass</td> </tr> <tr> <td>Highest dmax (%):</td> <td>1.26</td> <td>Test limit:</td> <td>1.000</td> <td>Pass</td> </tr> <tr> <td>Highest Pst (10 min. period):</td> <td>0.653</td> <td>Test limit:</td> <td>0.650</td> <td>Pass</td> </tr> <tr> <td>Highest Plt (2 hr. period):</td> <td>0.644</td> <td></td> <td></td> <td></td> </tr> </table>			Vrms at the end of test (Volt):	232.41	Test limit (mS):	500.0	Pass	T-max (mS):	0.0	Test limit (%):	3.30	Pass	Highest dc (%):	0.00	Test limit (%):	4.00	Pass	Highest dmax (%):	1.26	Test limit:	1.000	Pass	Highest Pst (10 min. period):	0.653	Test limit:	0.650	Pass	Highest Plt (2 hr. period):	0.644			
Vrms at the end of test (Volt):	232.41	Test limit (mS):	500.0	Pass																												
T-max (mS):	0.0	Test limit (%):	3.30	Pass																												
Highest dc (%):	0.00	Test limit (%):	4.00	Pass																												
Highest dmax (%):	1.26	Test limit:	1.000	Pass																												
Highest Pst (10 min. period):	0.653	Test limit:	0.650	Pass																												
Highest Plt (2 hr. period):	0.644																															
Remark																																

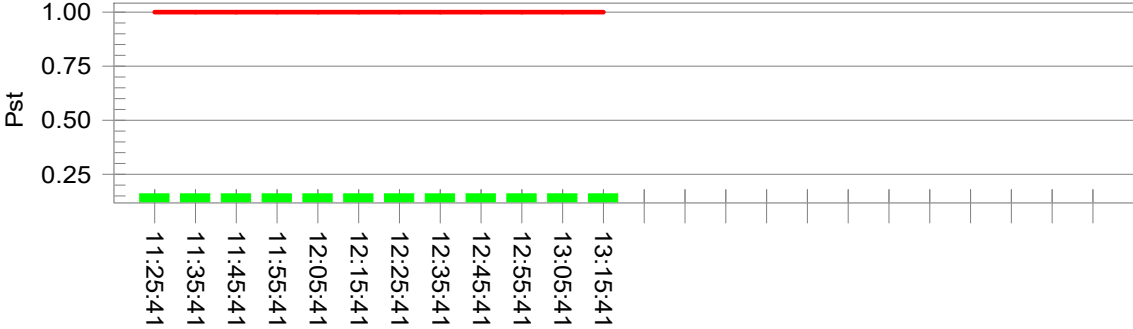
Measurement data		Port under test	AC mains port – Line 1
Operating mode used during the test		Mode 5/ Input: 480 Vdc, Output: 400 Vac	
Test Result: Pass		Status: Test Completed	
Pst and limit line		European Limits	
			
Plt and limit line			
			
Parameter values recorded during the test:			
Vrms at the end of test (Volt):	231.14	Test limit (mS):	500.0 Pass
T-max (mS):	0.0	Test limit (%):	3.30 Pass
Highest dc (%):	0.00	Test limit (%):	4.00 Pass
Highest dmax (%):	0.12	Test limit:	1.000 Pass
Highest Pst (10 min. period):	0.160	Test limit:	0.650 Pass
Highest Plt (2 hr. period):	0.160		
Remark			

Measurement data	Port under test	AC mains port – Line 2																								
Operating mode used during the test	Mode 5/ Input: 480 Vdc, Output: 400 Vac																									
<p>Test Result: Pass Status: Test Completed</p> <p>Pst and limit line European Limits</p>  <p>Plt and limit line</p>  <p>Parameter values recorded during the test:</p> <table border="0"> <tr> <td>Vrms at the end of test (Volt):</td> <td>231.67</td> <td></td> <td></td> </tr> <tr> <td>T-max (mS):</td> <td>0.0</td> <td>Test limit (mS):</td> <td>500.0 Pass</td> </tr> <tr> <td>Highest dc (%):</td> <td>0.00</td> <td>Test limit (%):</td> <td>3.30 Pass</td> </tr> <tr> <td>Highest dmax (%):</td> <td>0.10</td> <td>Test limit (%):</td> <td>4.00 Pass</td> </tr> <tr> <td>Highest Pst (10 min. period):</td> <td>0.160</td> <td>Test limit:</td> <td>1.000 Pass</td> </tr> <tr> <td>Highest Plt (2 hr. period):</td> <td>0.160</td> <td>Test limit:</td> <td>0.650 Pass</td> </tr> </table>			Vrms at the end of test (Volt):	231.67			T-max (mS):	0.0	Test limit (mS):	500.0 Pass	Highest dc (%):	0.00	Test limit (%):	3.30 Pass	Highest dmax (%):	0.10	Test limit (%):	4.00 Pass	Highest Pst (10 min. period):	0.160	Test limit:	1.000 Pass	Highest Plt (2 hr. period):	0.160	Test limit:	0.650 Pass
Vrms at the end of test (Volt):	231.67																									
T-max (mS):	0.0	Test limit (mS):	500.0 Pass																							
Highest dc (%):	0.00	Test limit (%):	3.30 Pass																							
Highest dmax (%):	0.10	Test limit (%):	4.00 Pass																							
Highest Pst (10 min. period):	0.160	Test limit:	1.000 Pass																							
Highest Plt (2 hr. period):	0.160	Test limit:	0.650 Pass																							
Remark																										

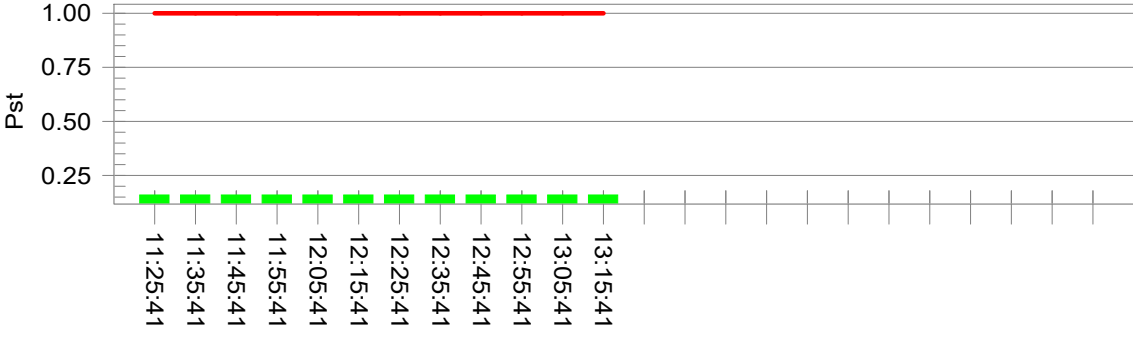
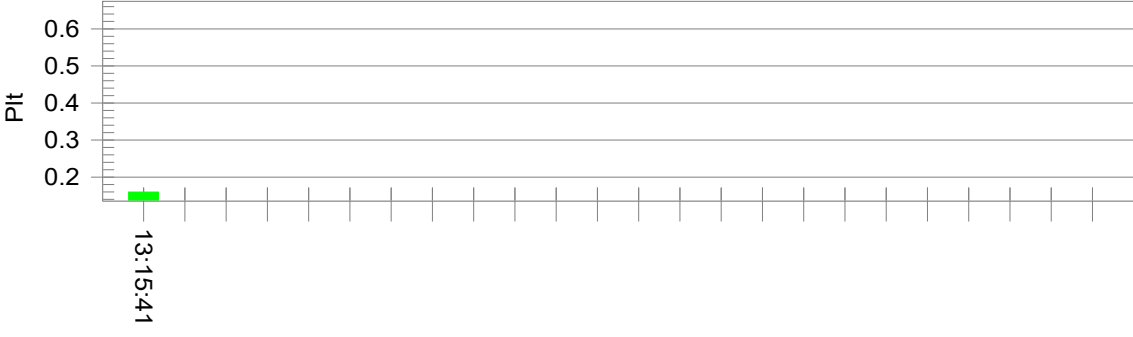
Measurement data		Port under test	AC mains port – Line 3
Operating mode used during the test		Mode 5/ Input: 480 Vdc, Output: 400 Vac	
Test Result: Pass		Status: Test Completed	
Pst and limit line		European Limits	
			
Plt and limit line			
			
Parameter values recorded during the test:			
Vrms at the end of test (Volt):	231.93	Test limit (mS):	500.0 Pass
T-max (mS):	0.0	Test limit (%):	3.30 Pass
Highest dc (%):	0.00	Test limit (%):	4.00 Pass
Highest dmax (%):	0.12	Test limit:	1.000 Pass
Highest Pst (10 min. period):	0.160	Test limit:	0.650 Pass
Highest Plt (2 hr. period):	0.160		
Remark			

5 IMMUNITY TEST RESULTS

5.1 Performance (Compliance) criteria

[Source: EN IEC 61000-6-2]

Performance criterion A: The EUT shall continue to operate as intended during and after the test. No degradation of performance or loss of function is allowed below a performance level specified by the manufacturer, when the EUT is used as intended. If the performance level is not specified by the manufacturer, this may be derived from the product description and documentation and what the user may reasonably expect from the equipment if used as intended.

Performance criterion B: The EUT shall continue to operate as intended after the test. No degradation of performance or loss of function is allowed below a performance level specified by the manufacturer, when the EUT is used as intended. The performance level may be replaced by a permissible loss of performance. However, during the test degradation of performance is allowed but no change of actual operating state or stored data is allowed. If the minimum performance level or the permissible performance loss is not specified by the manufacturer, either of these may be derived from the product description and documentation and what the user may reasonably expect from the equipment if used as intended.

Performance criterion C: Temporary loss of function is allowed during the test, provided the function is self-recoverable or can be restored by the operation of the controls.

5.1.1 Performance criteria related to immunity tests

Immunity test	Performance criteria
Electrostatic discharge	B
Radio-frequency electromagnetic fields	A
Fast transients	B
Surge transient	B
Injected currents (radio-frequency common mode)	A
Power frequency magnetic field immunity	A
Voltage dips and short interruptions	B, C

5.1.2 Manufacturer defined performance criteria

Not provided.

5.2 Monitored – Checked Functions / Parameters

During the immunity tests the following functions of the EUT has/have been monitored/checked.

<input type="checkbox"/>	Motor speed	<input type="checkbox"/>	Display data
<input type="checkbox"/>	Switching	<input type="checkbox"/>	Data storage
<input type="checkbox"/>	Standby mode	<input type="checkbox"/>	Sensor functions
<input type="checkbox"/>	Temperature	<input type="checkbox"/>	Audible signals
<input type="checkbox"/>	Power consumption	<input checked="" type="checkbox"/>	Others: Output Voltage
<input type="checkbox"/>	AC mains input current	<input checked="" type="checkbox"/>	Others: Output Current
<input type="checkbox"/>	Timing	<input checked="" type="checkbox"/>	Others: Screen
<input type="checkbox"/>	Illumination	<input type="checkbox"/>	Others:
<u>Supplementary information:</u>			

Immunity test	Monitored - Checked function(s)/parameter(s) during / after the test	Method
Electrostatic discharge	Pass	Visual
Radio-frequency electromagnetic fields	Pass	Camera
Fast transients	Pass	Visual
Surge transient	Pass	Visual
Injected currents (radio-frequency common mode)	Pass	Visual
Power frequency magnetic field immunity	Pass	Visual
Voltage dips and short interruptions	N/A	N/A
<u>Supplementary information:</u>		

5.3 Electrostatic discharge immunity	VERDICT: PASS
---	----------------------

Electrostatic discharges (ESD) are the result of persons or objects that accumulate static electricity due to for instance walking on synthetic carpets. The ESD can influence the operation of equipment or damage its electronics, either by a direct discharge or indirectly by coupling or radiation. Both effects are simulated during the tests.

Requirements

Standard	EN IEC 61000-6-2						
Basic standard	EN 61000-4-2						
Port under test	Enclosure						
Air discharges	<input checked="" type="checkbox"/>	± 2 kV	<input checked="" type="checkbox"/>	± 4 kV	<input checked="" type="checkbox"/>	± 8 kV	<input type="checkbox"/> kV
Contact discharges	<input type="checkbox"/>	± 2 kV	<input checked="" type="checkbox"/>	± 4 kV	<input type="checkbox"/>	± 8 kV	<input type="checkbox"/> kV
Number of discharges	≥ 10 per polarity with ≥ 1 sec interval.						
Performance criterion	B; During the test degradation is allowed. No change of operating state or stored data is allowed. Refer to the chapter 5.1 for details.						

Performed tests

Set-up	<input checked="" type="checkbox"/>	Table-top	<input type="checkbox"/>	Floor standing
Ambient temperature [°C]	24		Relative Humidity air [%]	35
Voltage – Mains [V]	Input: 480 Vdc, Output: 400 Vac			
Frequency – Mains [Hz]	50 Hz			
Operating mode(s) used	Mode 4			

	Test Point	Test Voltage [kV] & Polarity	Coupling type	# of applied discharges / polarity	Discharge interval [s]
<input checked="" type="checkbox"/>	Metal Enclosure	± 4	Contact	10	1
<input checked="" type="checkbox"/>	Screws	± 4	Contact	10	1
<input checked="" type="checkbox"/>	Radiator	± 4	Contact	10	1
<input checked="" type="checkbox"/>	Seam	± 2 / ± 4 / ± 8	Air	10	1
<input checked="" type="checkbox"/>	Non-metal terminals	± 2 / ± 4 / ± 8	Air	10	1
<input checked="" type="checkbox"/>	Screen	± 2 / ± 4 / ± 8	Air	10	1
<input checked="" type="checkbox"/>	DC Switch	± 2 / ± 4 / ± 8	Air	10	1
<input checked="" type="checkbox"/>	HCP top side.	± 4	Contact	10	1
<input checked="" type="checkbox"/>	HCP bottom side.	± 4	Contact	10	1
<input checked="" type="checkbox"/>	VCP right side.	± 4	Contact	10	1
<input checked="" type="checkbox"/>	VCP left side.	± 4	Contact	10	1
<input checked="" type="checkbox"/>	VCP front side.	± 4	Contact	10	1
<input checked="" type="checkbox"/>	VCP rear side.	± 4	Contact	10	1

Observation(s)	During the test no loss of performance was observed. After the test the EUT functioned as intended. No unacceptable loss of performance or data was observed.
Supplementary information:	

5.4	Radio-frequency electromagnetic fields immunity	VERDICT: PASS
------------	--	----------------------

During the test it is verified if the equipment under test (EUT) has sufficient immunity against radiated electromagnetic fields. Industrial electromagnetic sources, walkie-talkies, radio transmitters, television transmitters and telecommunication equipment including cellular telephones and other emitting devices can generate these fields.

Requirements

Standard	EN IEC 61000-6-2			
Basic standard	EN 61000-4-3			
Port under test	Enclosure			
Frequency range	Test level	Modulation	Dwell time	Step size
80 – 1000 MHz	10 V/m	80% AM (1kHz)	≥ 0,5 s	≤ 1%
1400 – 6000 MHz	3 V/m	80% AM (1kHz)	≥ 0,5 s	≤ 1%
<u>Supplementary information:</u>				

Performed tests

Test method	<input checked="" type="checkbox"/>	EN 61000-4-3				
Test set-up	<input checked="" type="checkbox"/>	Equipment on the table (0,8 m height)				
(see annex 2 for photo)	<input type="checkbox"/>	Equipment standing on floor (0,05 – 0,15 m height)				
Voltage – Mains [V]	Input: 480 Vdc, Output: 400 Vac		Frequency – Mains [Hz]	50 Hz		
Operating mode(s) used	Mode 4					
Frequency range (applied)	Antenna Polarization	Test level (applied)	Modulation (applied)	Dwell time (applied)	Remark	
80 – 1000 MHz (step size 1%)	H	10 V/m	80% AM (1kHz)	3 s	---	
	V	10 V/m	80% AM (1kHz)	3 s	---	
1400 – 6000 MHz (step size 1%)	H	3 V/m	80% AM (1kHz)	3 s	---	
	V	3 V/m	80% AM (1kHz)	3 s	---	
Exposed side of the EUT	<input checked="" type="checkbox"/>	Front (0°)	<input checked="" type="checkbox"/>	Right (90°)	<input type="checkbox"/>	Top
	<input checked="" type="checkbox"/>	Rear (180°)	<input checked="" type="checkbox"/>	Left (270°)	<input type="checkbox"/>	Bottom
Observation(s)	During the test no loss of performance was observed. After the test the EUT functioned as intended. No unacceptable loss of performance or data was observed.					
<u>Supplementary information:</u>						

5.5 Electrical Fast Transients immunity	VERDICT: PASS
--	----------------------

The EFT immunity test simulates disturbances by bursts of very short transients caused for example by switching off loads such as an AC motor or bouncing relay contacts. The transients are likely to disturb electronics but less likely to cause damage.

Requirements

Standard	EN IEC 61000-6-2		
Basic standard	EN 61000-4-4		
Pulse characteristics	5/50 ns		
Port	Test level	Repetition frequency	Duration
AC input-output power	± 2000 V	5 KHz	≥1 min. / polarity
DC input-output power ²⁾	± 1000 V	5 KHz	≥1 min. / polarity
Signal ports ¹⁾	± 1000 V	5 KHz	≥1 min. / polarity
¹⁾ Only applicable to ports interfacing with cables whose total length may exceed 3 m. ²⁾ Not applicable to input ports intended for connection to a battery or a rechargeable battery which must be removed or disconnected from the apparatus for recharging. Apparatus with a DC power input port intended for use with an AC-DC power adaptor shall be tested on the AC power input of the AC- DC power adaptor specified by the manufacturer or, where none is so specified, using a typical AC-DC power adaptor. The test is applicable to DC power input ports intended to be connected permanently to cables longer than 3 m.			

Performed tests

Voltage – Mains [V]	Input: 200/480 Vdc, Output: 400 Vac		
Frequency – Mains [Hz]	50 Hz		
Operating mode(s) used	Mode 4		
Test Set-up (see annex 2 for photo)	<input type="checkbox"/>	Equipment standing on floor at (0,1 ± 0,01) m above ground plane	
	<input checked="" type="checkbox"/>	Equipment on the table (0,1 ± 0,01) m above ground plane	
	<input type="checkbox"/>	Artificial hand applied. Location refer to chapter 8.	
Coupling	<input checked="" type="checkbox"/>	Common mode	<input type="checkbox"/> Other:

Port under test	Test Voltage &Polarity	Repetition Frequency	Test duration	Injection method		
DC input port	± 1 kV	5 KHz	60 s	<input checked="" type="checkbox"/>	CDN	<input type="checkbox"/> Clamp
AC output port	± 2 kV	5 KHz	60 s	<input checked="" type="checkbox"/>	CDN	<input type="checkbox"/> Clamp
Observation(s)	During the test no loss of performance was observed. After the test the EUT functioned as intended. No unacceptable loss of performance or data was observed.					
Supplementary information:						

5.6	Surge transient immunity	VERDICT: PASS
------------	---------------------------------	----------------------

The surge transient immunity test simulates the surges that are caused by over-voltages due to indirect (induced) lightning transients. The pulse is a slow transient with high-energy contents and due to its long duration may cause damage to an unprotected EUT.

Requirements

Standard	EN IEC 61000-6-2		
Basic standard	EN 61000-4-5		
Pulse characteristics	1,2/50µs Voltage; 8/20µs Current		
Repetition rate	≤ 60 secs. (for each test level and phase angle)		
Number of pulses	5 pulses (at each polarity and phase angle)		
Port	Test level & Polarity & Coupling		Phase angle [°]
	Line to Line ¹⁾	Line to Earth ¹⁾	
AC input-output power	± 1 kV	± 2 kV	0, 90, 180, 270
DC input-output power ²⁾	± 0.5 kV	± 1 kV	---
Signal/control ports ³⁾	N/A	± 1 kV	
¹⁾ In addition to the specified test level, all lower test levels as detailed in EN 61000-4-5 should also be satisfied. ²⁾ Not applicable to input ports intended for connection to a battery or a rechargeable battery which must be removed or disconnected from the apparatus for recharging. Apparatus with a DC power input port intended for use with an AC-DC power adaptor shall be tested on the AC power input of the AC-DC power adaptor specified by the manufacturer or, where none is so specified, using a typical AC-DC power adaptor. DC ports, which are not intended to be connected to a DC distribution network are treated as signal ports. ³⁾ Applicable only to ports interfacing with long distance lines.			

Performed tests

Voltage – Mains [V]	Input: 200/480 Vdc, Output: 400 Vac
Frequency – Mains [Hz]	50 Hz
Operating mode(s) used	Mode 4
Repetition rate	60 secs. (for each test level and phase angle)
Number of pulses	5 pulses (at each polarity and phase angle)

Port under test		Coupling	Test level & Polarity	Phase angle [°]	Remark
<input checked="" type="checkbox"/>	DC input port	Line to Line	± 0.5 kV	---	---
<input checked="" type="checkbox"/>	DC input port	Line to Earth	± 1 kV	---	---
<input checked="" type="checkbox"/>	AC output port	Line to Line	± 1 kV	0, 90, 180, 270	---
<input checked="" type="checkbox"/>	AC output port	Line to Earth	± 2 kV	0, 90, 180, 270	---
Observation(s)		During the test no loss of performance was observed. After the test the EUT functioned as intended. No unacceptable loss of performance or data was observed.			
Supplementary information:					

5.7	Injected currents (RF common mode) immunity	VERDICT: PASS
------------	--	----------------------

During this test the immunity of the equipment for induced or conducted electromagnetic fields is checked. Fields generated by radio and other transmitters cause RF voltages in long cables like the mains network. This test reproduces these induced disturbing voltages by injecting them to the EUT via the cabling.

Requirements

Standard	EN IEC 61000-6-2				
Basic standard	EN 61000-4-6				
Frequency range	0,15 – 80 MHz				
Port	Test level, U_0	Modulation	Step size	Dwell time	
AC input-output power	10 V	80% AM (1kHz)	$\leq 1\%$	$\geq 0,5$ s	
DC input-output power ¹⁾	10 V	80% AM (1kHz)	$\leq 1\%$	$\geq 0,5$ s	
Signal port ¹⁾	10 V	80% AM (1kHz)	$\leq 1\%$	$\geq 0,5$ s	
¹⁾ Only applicable to ports interfacing with cables whose total length, may exceed 3 m.					

Performed tests

Test method (applied)	Frequency range (applied)	Modulation (applied)	Step size (applied)		
IEC 61000-4-6	0,15 – 80 MHz	80% AM (1kHz)	1%		
Voltage – Mains [V]	Input: 480 Vdc, Output: 400 Vac	Frequency – Mains [Hz]	50 Hz		
Operating mode(s) used	Mode 4				
Test set-up (see annex 2 for photo)	<input type="checkbox"/>	Equipment standing on floor at (0,1 ± 0,01) m above ground plane.			
	<input checked="" type="checkbox"/>	Equipment on the table (0,1 ± 0,01) m above ground plane.			
	<input type="checkbox"/>	Artificial hand applied. Location refer to Annex 2.			
Port under test	Test Level (applied)	Injection method	Dwell time (applied)	Remark	
DC input port	10 V	Clamp	3 s	---	
AC output port	10 V	Clamp	3 s	---	
Observation(s)	During the test no loss of performance was observed. After the test the EUT functioned as intended. No unacceptable loss of performance or data was observed.				
<u>Supplementary information:</u>					

5.8	Power frequency magnetic field immunity	VERDICT: PASS
------------	--	----------------------

Magnetic fields caused by for example nearby mains frequency transformers may disturb equipment with sensitivity for these types of disturbances such as CRT monitors.

Requirements

Standard	EN IEC 61000-6-2
Basic standard	EN 61000-4-8
Port under test	Enclosure
Field strength	30 A/m
Test Frequency	50 / 60 Hz
Notes: Applicable only to apparatus containing devices susceptible to magnetic fields.	

Performed tests

Reason for not performing the test	<input type="checkbox"/>	The test is not applicable as the apparatus does not contain any components susceptible to this low-frequency magnetic fields.
Voltage – Mains [V]	Input: 480 Vdc, Output: 400 Vac	
Frequency – Mains [Hz]	50 Hz	
Operating mode(s) used	Mode 4	
Test set-up (see annex 2 for photo)	<input checked="" type="checkbox"/>	Single Coil. Dimensions: 1 m x 1 m
	<input type="checkbox"/>	Single Coil. Dimensions: 2 m x 2 m
	<input type="checkbox"/>	Homogeneous field (Helmholtz coil). Dimensions: 1 m x 1 m
	<input type="checkbox"/>	0,1 m above metal surface

Axis under test		Tested Field strength	Test Frequency	Test Duration	Remark
<input checked="" type="checkbox"/>	X-axis	30 A/m	50, 60 Hz	60 s	---
<input checked="" type="checkbox"/>	Y-axis	30 A/m	50, 60 Hz	60 s	---
<input checked="" type="checkbox"/>	Z-axis	30 A/m	50, 60 Hz	60 s	---
Observation(s)		During the test no loss of performance was observed. After the test the EUT functioned as intended. No unacceptable loss of performance or data was observed.			
<u>Supplementary information:</u>					

5.9	Power supply interruptions and dips immunity	VERDICT: N/A
------------	---	---------------------

The purpose of the test is to verify the immunity of the equipment against voltage dips and voltage interruptions. It helps to ensure that the equipment functions properly (as expected and safely) with power supply fluctuations. Voltage dips and interruptions are caused by faults in the LV, MV, HV networks (short-circuit or ground faults).

Requirements

Standard	EN IEC 61000-6-2			
Basic standard	EN 61000-4-11			
# of dips & interruptions	3 dips / interruptions for each test level and phase angle			
Interval between events	≥ 10 seconds			
Port under test	Test level ¹⁾	Period (Cycles)		Performance Criterion
		50 Hz	60 Hz	
AC input power port	U _{NOM} – 100%	1	1	B; Refer to the chapter 5.1 for details.
AC input power port	U _{NOM} – 60%	10	12	B; Refer to the chapter 5.1 for details.
AC input power port	U _{NOM} – 30%	25	30	C; Refer to the chapter 5.1 for details.
AC input power port	U _{NOM} – 100%	250	300	C; Refer to the chapter 5.1 for details.
¹⁾ Changes to the voltage level shall occur at a zero crossing point in the a.c. voltage waveform. NOTE: Where the equipment has a rated voltage range the following shall apply: <ul style="list-style-type: none"> - If the voltage range does not exceed 20% of the lower voltage specified for the rated voltage range. A single voltage within that range may be selected for testing. - In all other cases, the test procedure shall be applied for both the lowest and highest voltages declared in the voltage range. 				

Performed tests

U _{NOM} [V _{AC}]	Terminal	Test level [% U _{NOM}]	Duration [cycles]		Repetition rate [s]	Number of dips per test	Phase angle [°]
			50 Hz	60 Hz			
1) Applicable only to input ports. 2) Not applicable because no test requirements have been specified for DC/battery powered apparatus.							
Operating mode(s) used		---					
Observation(s)		---					
<u>Supplementary information:</u>							

6 IDENTIFICATION OF THE EQUIPMENT UNDER TEST

Conducted disturbance voltage

Instrument	Manufacturer	Model No.	Serial No.	Cali. Date	Cali. Due Date
EMI Test Receiver	R&S	ESR7	102086	2022-03-05	2023-03-04
Artificial Mains Network	SCHWARZBECK	NNLK 8129	8129-282	2022-03-05	2023-03-04
DC-AMN	SCHWARZBECK	PVDC 8301	8301-070	2021-11-11	2022-11-10
50ohm Termination	SHX	TF2	07081402	2021-09-04	2022-09-03
50ohm Termination	SHX	TF2	07081403	2021-09-04	2022-09-03
50ohm Coaxial Switch	Anritsu	MP59B	6200464462	N/A	N/A
Coaxial Cable	Suhner	RG 223	TR1-C1	2022-03-12	2023-03-11
Temperature/Humidity Meter	RTS	RTS-8S	AC1-TH	2021-07-09	2022-07-08

Radiated Emission (30MHz - 1GHz)

Instrument	Manufacturer	Model No.	Serial No.	Cali. Date	Cali. Due Date
EMI Test Receiver	R&S	ESCI	100175	2021-07-11	2022-07-10
EMI Test Receiver	R&S	ESCI	100726	2021-10-30	2022-10-29
Preamplifier	Quietek	AP-025C	CHM-0602008	2022-03-12	2023-03-11
Preamplifier	Quietek	AP-025C	CHM-0503006	2022-03-12	2023-03-11
TRILOG Broadband Antenna	SCHWARZBECK	VULB 9168	01100	2022-04-18	2023-04-17
TRILOG Broadband Antenna	SCHWARZBECK	VULB 9168	01099	2022-03-08	2023-03-07
Coaxial Cable	Huber+Suhner	RG 214_U	AC1-L	2022-03-12	2023-03-11
Coaxial Cable	Huber+Suhner	RG 214_U	AC1-R	2022-03-12	2023-03-11
Temperature/Humidity Meter	RTS	RTS-8S	AC1-TH	2021-07-09	2022-07-08

Harmonic current and flicker emissions ($I \leq 16A$, $16A < I \leq 75A$)

Instrument	Manufacturer	Model No.	Serial No.	Cali. Date	Cali. Due Date
Proflin 2145 Harmonics & Flicker and power line immunity test system	Teseq GmbH	Proflin 2145	1736A02510, 1646A, 01490, 1736A02428, 1736A00944, A41547	2021-10-30	2022-10-29
Temperature/Humidity Meter	RTS	RTS-8S	TR20-TH	2021-07-09	2022-07-08

ESD

Instrument	Manufacturer	Model No.	Serial No.	Cali. Date	Cali. Due Date
ESD Simulator	EM TEST	Dito	V0616101367	2022-03-14	2023-03-13
Barometer	Fengyun	DYM3	02251	2022-03-15	2023-03-14
Temperature/Humidity Meter	RTS	RTS-8S	TR21-TH	2021-07-09	2022-07-08

Radio-frequency electromagnetic field

Instrument	Manufacturer	Model No.	Serial No.	Cali. Date	Cali. Due Date
Signal Generator	R&S	SMB100A	114728	2021-07-11	2022-07-10
Power Meter	R&S	NRP2	106362	2021-07-11	2022-07-10
Power Sensor	R&S	NRP6A	101411	2021-07-11	2022-07-10
Power Sensor	R&S	NRP6B	101412	2021-07-11	2022-07-10

RF Switch	R&S	OPS120	101944	N/A	N/A
Power Amplifier	R&S	BBA150 BC500	102912	N/A	N/A
Power Amplifier	R&S	BBA150 D200	102889	N/A	N/A
Power Amplifier	R&S	BBA150 E200	102890	N/A	N/A
LOG Antenna	R&S	HL046E	100257	N/A	N/A
LOG Antenna	R&S	STLP9149	9149-505	N/A	N/A
Field Probe	AR	FL7006/KIT	350261	2021-11-15	2022-11-14
Temperature/Humidity Meter	RTS	RTS-8S	AC4-TH	2021-07-09	2022-07-08

Electrical fast transients

Instrument	Manufacturer	Model No.	Serial No.	Cali. Date	Cali. Due Date
Immunity Test System	Teseq GmbH	NSG 3060	4019	2022-03-05	2023-03-04
CDN	Teseq GmbH	CDN 3063	1997	2021-12-15	2022-12-14
Burst-EFT Dataline Coupling Clamp	Teseq GmbH	CDN 3425	2029	2021-07-11	2022-07-10
Temperature/Humidity Meter	RTS	RTS-8S	TR22-TH	2021-07-09	2022-07-08

Surges

Instrument	Manufacturer	Model No.	Serial No.	Cali. Date	Cali. Due Date
Immunity Test System	Teseq GmbH	NSG 3060	4019	2022-03-05	2023-03-04
CDN	Teseq GmbH	CDN 3063	1997	2021-12-15	2022-12-14
Temperature/Humidity Meter	RTS	RTS-8S	TR22-TH	2021-07-09	2022-07-08

Radio-frequency continuous conducted

Instrument	Manufacturer	Model No.	Serial No.	Cali. Date	Cali. Due Date
RF-Generator	Teseq	NSG 4070C-80	59355	2021-06-26	2022-06-25
Attenuation	Teseq	ATN 6150	N/A	N/A	N/A
EM Clamp	Teseq GmbH	KEMZ 801A	41411	2022-03-12	2023-03-11
Temperature/Humidity Meter	RTS	RTS-8S	TR22-TH	2021-07-09	2022-07-08

Power-frequency magnetic field

Instrument	Manufacturer	Model No.	Serial No.	Cali. Date	Cali. Due Date
Induction Coil Interface	Teseq GmbH	INA 2141	1443	2021-10-30	2022-10-29
Magnetic field Coil	Teseq GmbH	INA 703	3002	2021-10-30	2022-10-29
Temperature/Humidity Meter	RTS	RTS-8S	TR20-TH	2021-07-09	2022-07-08

Voltage dips and interruptions

Instrument	Manufacturer	Model No.	Serial No.	Cali. Date	Cali. Due Date
Proflin 2145 Harmonics & Flicker and power line immunity test system	Teseq GmbH	Proflin 2145	1736A02510, 1646A, 01490, 1736A02428, 1736A00944, A41547	2021-10-30	2022-10-29
Temperature/Humidity Meter	RTS	RTS-8S	TR20-TH	2021-07-09	2022-07-08

7 ANNEX 1 - MEASUREMENT UNCERTAINTIES

The table(s) below show(s) measurement uncertainties of the EMC test set-ups. The reported expanded uncertainties are based on a standard uncertainty multiplied by a coverage factor of k=2, providing a level of confidence of approximately 95%.

Conducted Emission
The maximum measurement uncertainty is evaluated as: 9kHz~30MHz: 3.09 dB
Radiated Emission (30MHz-1GHz)
The maximum measurement uncertainty is evaluated as: Horizontal: 30MHz~200MHz: 4.98 dB 200MHz~1GHz: 4.40 dB Vertical: 30MHz~200MHz: 5.28 dB 200MHz~1GHz: 4.36 dB
Radiated Emission (Above 1GHz)
The maximum measurement uncertainty is evaluated as: Horizontal: 1GHz~18GHz: 4.98 dB Vertical: 1GHz~18GHz: 4.79 dB
Harmonic current emissions
The maximum measurement uncertainty is evaluated as: 2.14 %.
Voltage fluctuations and flicker
The maximum measurement uncertainty is evaluated as: 1.80 %.
Electrostatic discharge
The maximum measurement uncertainty is evaluated as Rise Time: 6.4 %, Peak Current: 6 %, Current at 30 ns: 6 %, Current at 60 ns: 6 %.
Radio-frequency electromagnetic field
The maximum measurement uncertainty is evaluated as 1.48 dB.
Electrical fast transients
The maximum measurement uncertainty is evaluated as Voltage: 4%, Time: 2%.
Surges
The maximum measurement uncertainty is evaluated as Voltage: 4%, Time: 2%.
Radio-frequency continuous conducted
The maximum measurement uncertainty is evaluated as CDN: 1.52 dB, EM Clamp: 1.92 dB.
Power-frequency magnetic field
The maximum measurement uncertainty is evaluated as 10%.
Voltage dips and interruptions
The maximum measurement uncertainty is evaluated as Voltage: 4%, Time: 2%.

8 ANNEX 2 - TEST PHOTOS

Conducted disturbance voltage at AC mains port

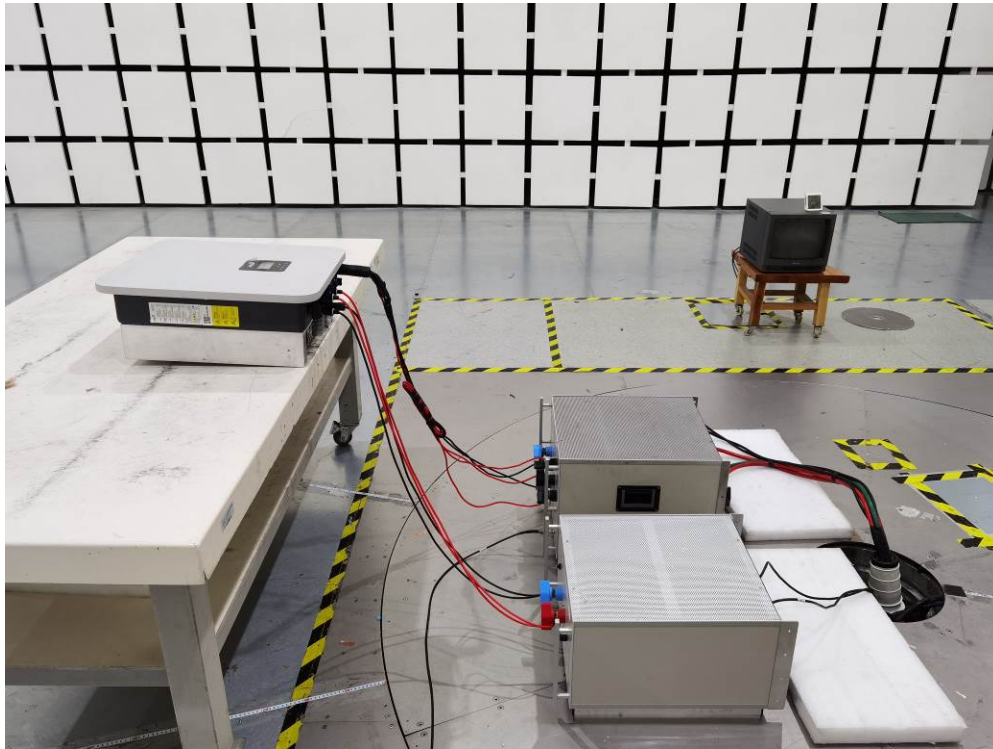

Conducted disturbance voltage at DC power port

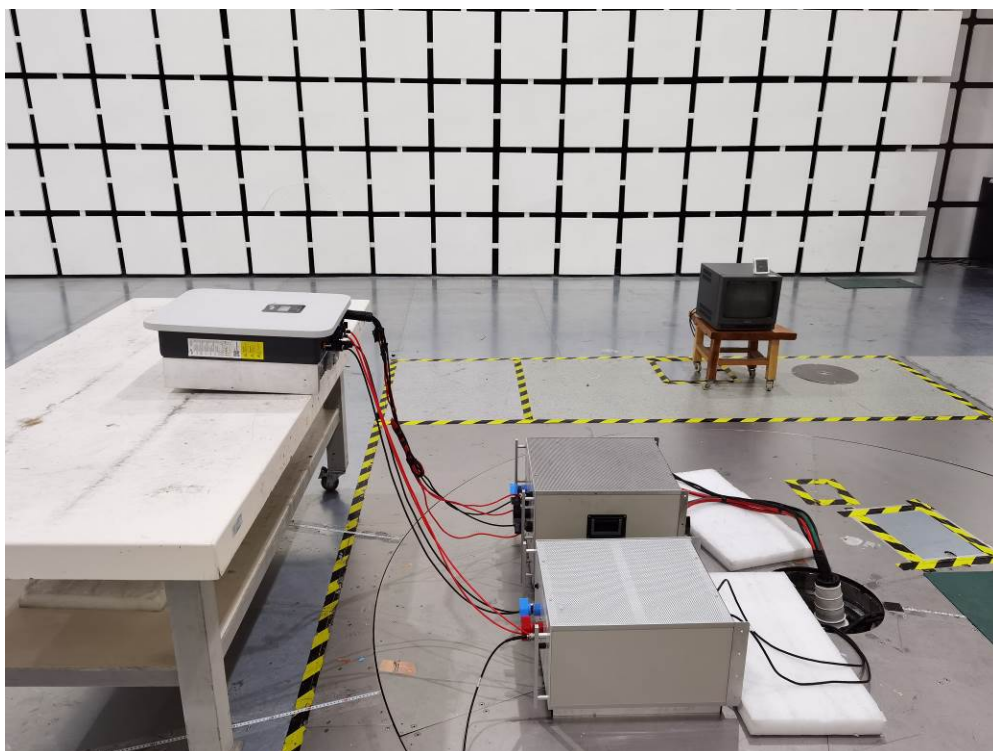

Radiated electromagnetic disturbances (30 MHz to 1000 MHz)



Harmonic current&flicker emissions



Electrostatic discharge immunity



Radiated EM Field Immunity (Below 1GHz)



Radiated EM Field Immunity (Above 1GHz)



Electrical fast transient (EFT) / Burst transients immunity

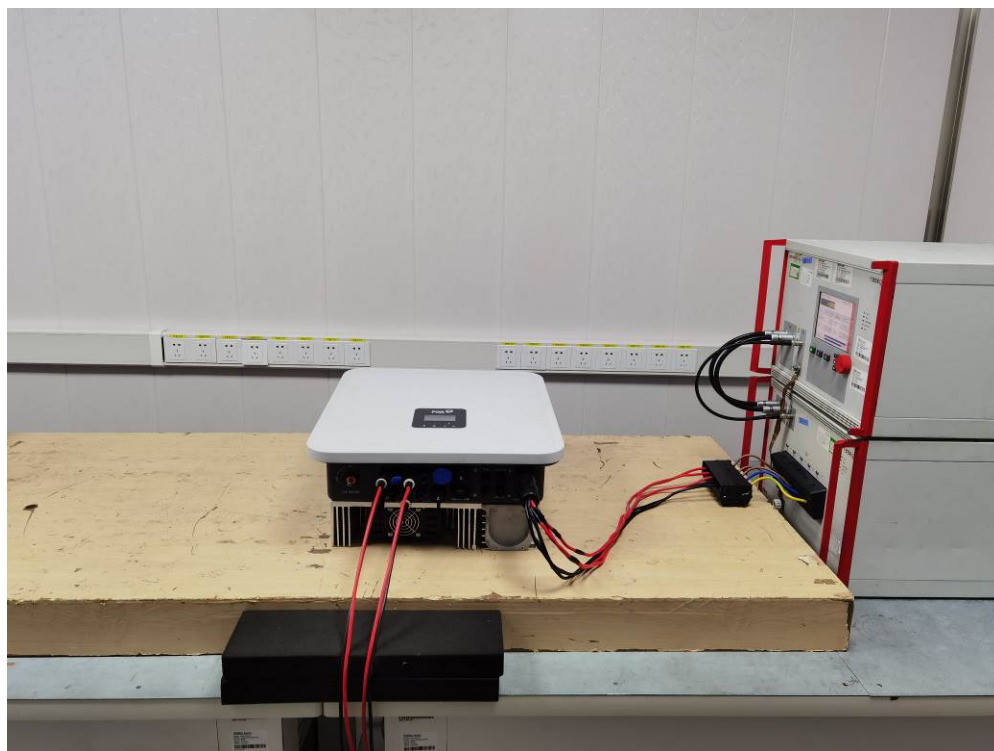

Surge transients immunity

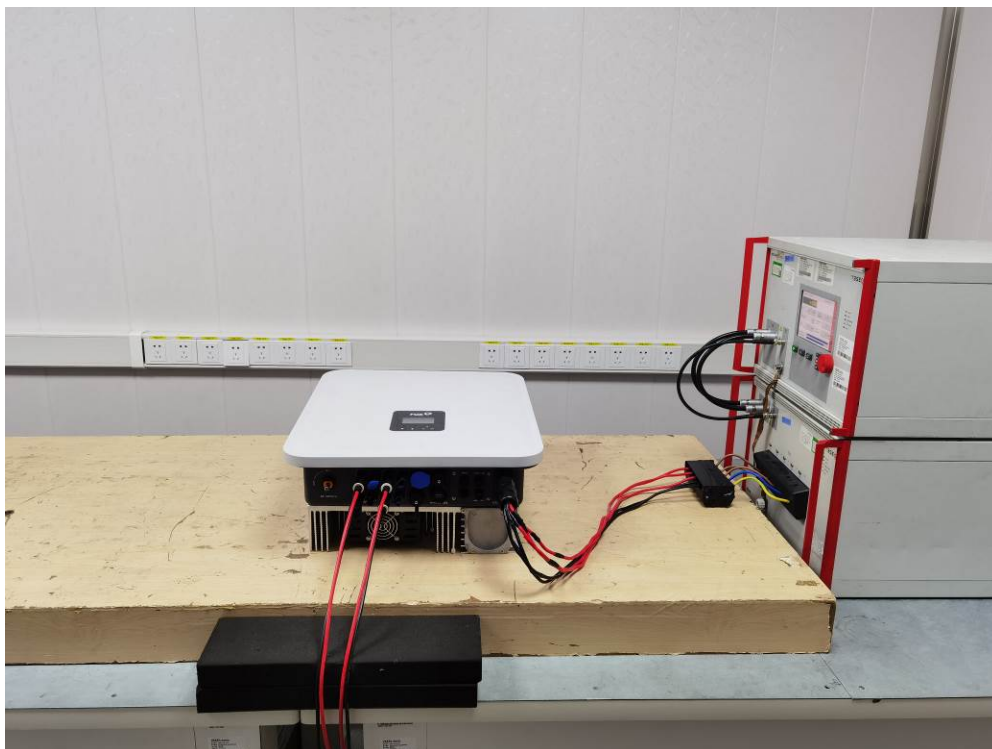

Conducted RF disturbances immunity

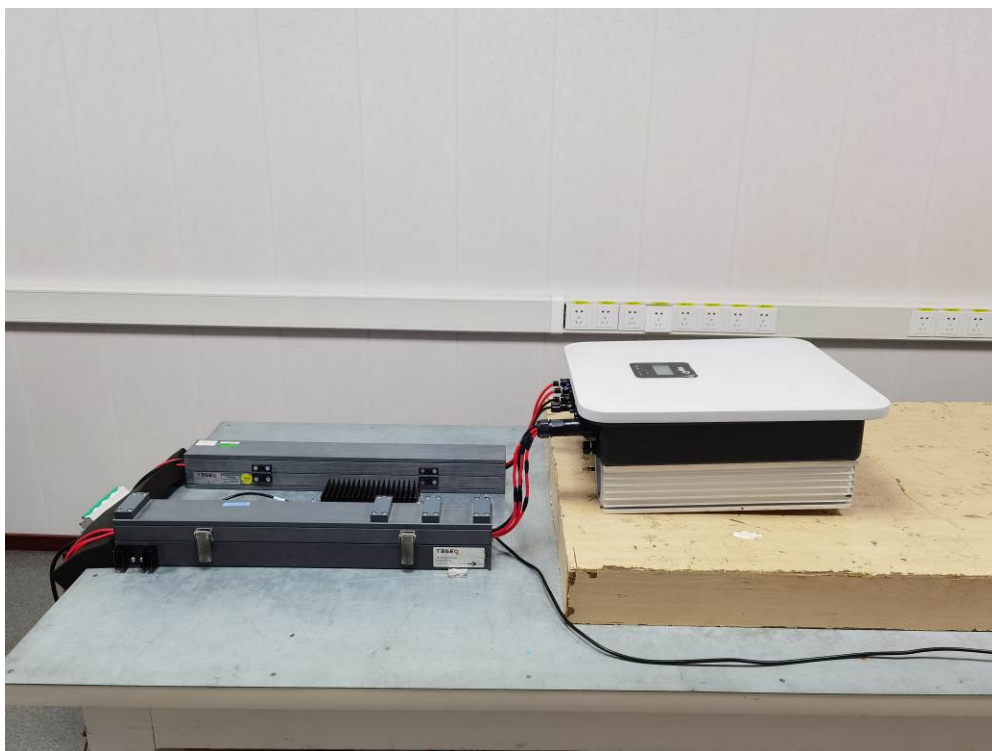

Power-frequency magnetic field immunity

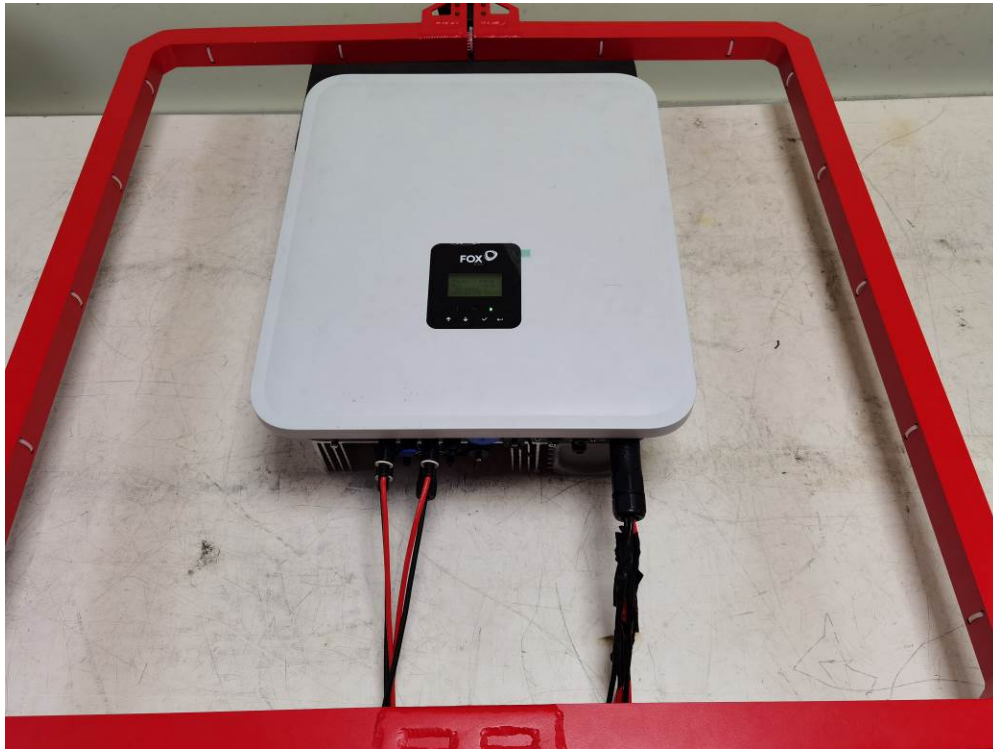

9 ANNEX 3 - EUT PHOTOS

EUT PHOTOS (1)



EUT PHOTOS (2)



EUT PHOTOS (3)



EUT PHOTOS (4)



End of the report