

# SigenStor Home Installation Guide

## Three-phase System A1

Version: 03  
Release date: 2024-05-31

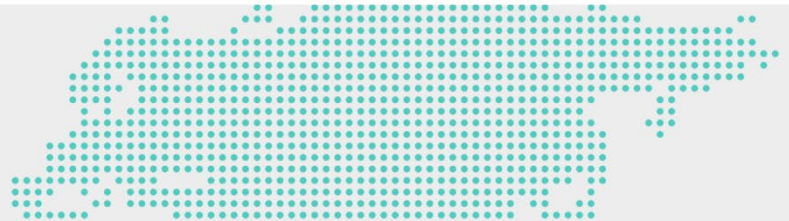

## ⚠ Caution

- Trained or experienced electrical personnel are required to operate the equipment.
- Operators should be familiar with national and local laws, regulations, and standards, and the compositions and operating principles of relevant systems.
- Please read carefully the operating requirements and precautions in this document and "Important Notice" before operating. Failure to do so may result in damage to the equipment that is not covered by the warranty.
- Please consult with the owner for expansion requirements (for example, adding battery packs, Sigen EV DC Charging Module, etc.). If any, please reserve necessary expansion space and cable length during installation.

# 1 Introduction to Three-phase System

## 1.1 Introduction to Networking

### Backup networking

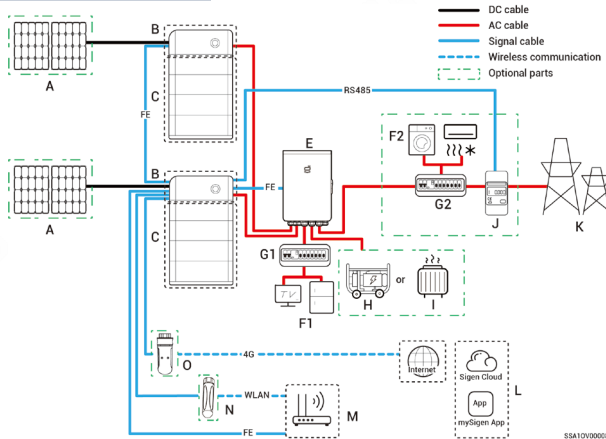

### Non-backup networking

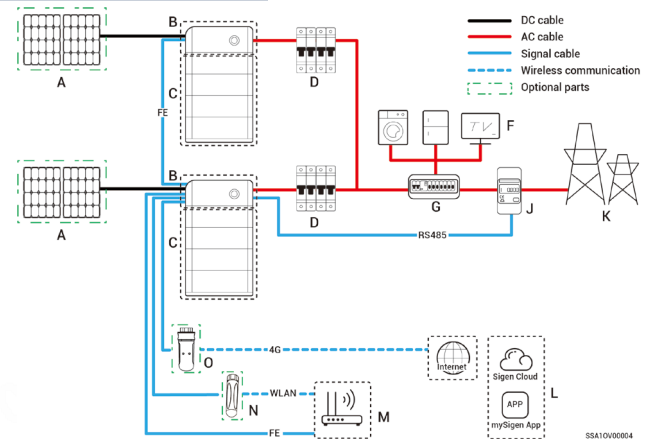

## Tips

It is recommended to use Fast Ethernet and WLAN for communication with inverters. 4G network data coming with Sigen CommMod free of charge is only suitable for a single device and is effective for 2 years. The traffic is insufficient in parallel connection scenarios. Users must replace the SIM card or top up their own data plan as needed.

S/N	Equipment/component	Model/version	Function specification
A	PV module	–	–
B	SigenStor EC	SigenStor EC 5.0/6.0/8.0/10.0/12.0/15.0/17.0/20.0/25.0 TP	Inverter; it can be used in photovoltaic energy storage scenarios and needs to be used together with PV modules and SigenStor BAT.
	SigenStor AC	SigenStor AC 5.0/6.0/8.0/10.0/12.0/15.0/17.0/20.0/25.0 TP	Inverter; it can be used in pure storage scenarios and needs to be used with SigenStor BAT.
	Sigen Hybrid	Sigen Hybrid 5.0/6.0/8.0/10.0/12.0/15.0/17.0/20.0/25.0 TP	Inverter; it can be used in conjunction with PV modules for pure PV applications or in combination with PV modules and SigenStor BAT for photovoltaic storage systems after the purchase and activation of a license.
C	SigenStor BAT	SigenStor BAT 5.0/8.0	Battery pack; it can store electric energy. Supports the simultaneous use of two models of battery packs.
D	AC switch	–	The rated voltage of the AC switch connected to each inverter should be $\geq 380$ Va.c., and the rated current is recommended: <ul style="list-style-type: none"> <li>• SigenStor EC/SigenStor AC/Sigen Hybrid (5.0–8.0) TP: The rated current is 25 A</li> <li>• SigenStor EC/SigenStor AC/Sigen Hybrid (10.0–15.0) TP: The rated current is 32 A</li> <li>• SigenStor EC/SigenStor AC/Sigen Hybrid (17.0–20.0) TP: The rated current is 40 A</li> <li>• SigenStor EC/SigenStor AC/Sigen Hybrid 25.0 TP: The rated current is 50 A</li> </ul>
E	Gateway	Gateway Three-phase Series Products	It's applicable for PV storage and pure storage applications to facilitate data acquisition and monitoring, off-grid backup power switching, diesel generator control, energy management; it must be used with SigenStor BAT and inverter. Gateway is a must-have for backup networking; for partial backup power and zero-power grid connection control networking, the Gateway and power sensor must be arranged.
F	Home loads		In a backup networking system, F1 represents the backup home loads, and F2 represents the non-backup loads.
G	Distribution panel		<ul style="list-style-type: none"> <li>• In the backup networking, G1 is the backup distribution panel, requiring a residual current device with rated residual operating current of 30 mA; G2 is the non-backup distribution panel.</li> <li>• The rated voltage of the AC switch of the distribution panel should be not less than 380 Va.c., And the rated current is recommended: that is, not less than the maximum output current of an inverter <math>\times</math> the number of inverters in parallel connection <math>\times 1.25^{[1]}</math>.</li> </ul>

Note [1]: The maximum output current of an inverter can be found in its respective data sheet.

S/N	Equipment/component	Model/version	Function specification
H	Diesel generator	–	As a backup energy source for long-term off-grid applications, it can work in tandem with the Gateway to provide a smooth transition between PV, storage and diesel generation.
I	Smart loads	–	All the power equipment in the owner's home can be connected as smart loads. To ensure that this product maximizes the benefits to users, it is recommended that the high-power equipment be connected as smart loads (heat pumps, pool heaters, clothes dryers, etc.), which can be cut off when the energy storage system has low power. Other low-power equipment are connected as home loads (lights, routers, etc.)
J	Power sensor	Sigen Sensor TP-DH (SDM630MODBUS V2) Sigen Sensor TP-CT120-DH (SDM630MCT 40mA/120A) Sigen Sensor TP-CT300-DH (SDM630MCT 40mA/300A) Sigen Sensor TP-CT600-DH (SDM630MCT V2/600A)	Data acquisition for grid connection points enables zero-power grid connection.
K	Power grid	–	–
L	App	mySigen	Android 6.0 or later iOS 12.0 onwards
M	Router	–	To be used for FE/WLAN communication.
N	Antenna	–	To be used for WLAN communication.
O	Communication module	Sigen CommMod	To be used for 4G communication.

## Tips

- When configuring the Gateway, refer to the Installation Guide of the respective Gateway model for detailed installation procedures.
- When adding a Sigen EV DC Charging Module, refer to the Installation Guide of the respective Sigen EV DC Charging Module model for detailed installation procedures.

## 1.2 Appearance and Dimensions

### Inverter and battery pack

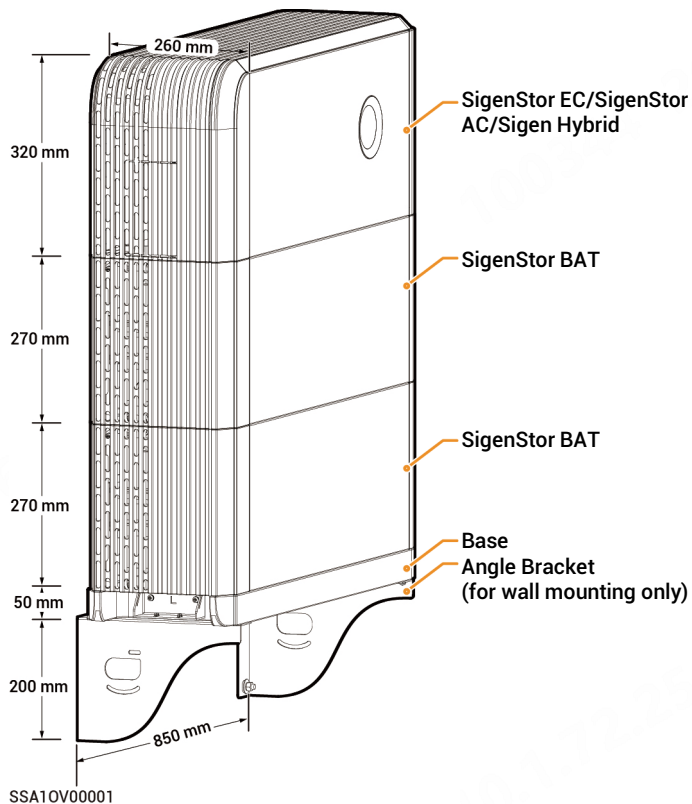

## 1.3 Port Descriptions

### SigenStor EC/SigenStor AC/Sigen Hybrid Left View

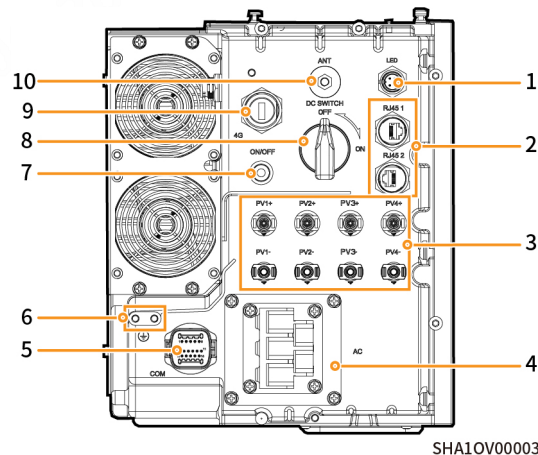

S/N	Name	Marking
1	Decorative cover light strip connector	LED
2	Network interface	RJ45 1/ RJ45 2
3	DC input interface	PV1+/PV2+/ PV3+/PV4+/ PV1- /PV2- /PV3-/PV4-
4	AC output interface	AC
5	Communication interface	COM
6	Ground screw	-
7	Switch button	ON/OFF
8	DC switch	DC SWITCH
9	Sigen CommMod interface	4G
10	Antenna interface	ANT

## 2 Pre-installation Check

- Check whether the components are entirely supplied against the packing list and whether the appearance is in good condition. For any problem, contact your sales representative.
- Parts and accessories supplied with the packing box are personal assets of the owner and must not be taken away from the installation site.
- Check personal protective equipment and installation tools to ensure that they are complete; If not, please make them up.
- Check and ensure the completeness of personal protective equipment and installation tools; replenish if necessary.

### Protective equipment



Safety hat



Goggles



Dust mask



Protective gloves



Insulating gloves



Insulating shoes

### Installation tool

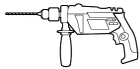

Power drill

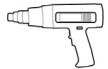

Heat gun

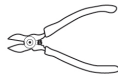

Wire cutter



Crimp tool



Crimping pliers



Wire stripper



Scissors



Cable tie



Heat shrinkable sleeve



Insulation sleeve set



Torque socket wrench



Marker



Rubber mallet



hexagonal L-type wrench (4mm on opposite side)



Tape measure

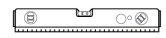

Level



Vacuum cleaner

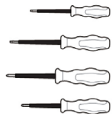

Insulation screwdriver set



Open-end wrench  
(model: H4TW0001  
Manufacturer:  
Amphenol)



Crimping pliers  
(model: H4TC0003  
Manufacturer:  
Amphenol)



(Optional) Stainless steel covered plastic steel rope (bearing:  $\geq 250$  kg Diameter: 3 mm)

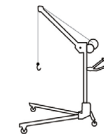

(Optional) Lift  
(used when SigenStor  
BAT  $\geq 3$  units)



(Optional) Lock  
(Lock bar diameter  $\leq 5$  mm)

## ⚠ Caution

- The specifications of the Installer-provided cable must comply with the cable regulations and standards of the country or region standards.
- L1, L2, L3, N and PE should be connected to other equipment in sequence without mixing.

### Installer-provided cable

S/N	Cable name	Recommended specifications										
1	Protective ground cable of inverter housing	<p>Outdoors single core copper flexible cable</p> <ul style="list-style-type: none"> <li>• SigenStor EC / SigenStor AC / Sigen Hybrid (5.0–15.0) TP: Cross-sectional area of core conductor: 4–6 mm<sup>2</sup></li> <li>• SigenStor EC / SigenStor AC / Sigen Hybrid (17.0–20.0) TP: Cross-sectional area of core conductor: 6–10 mm<sup>2</sup></li> <li>• SigenStor EC / SigenStor AC / Sigen Hybrid 25.0 TP: Cross-sectional area of core conductor: 10–16 mm<sup>2</sup></li> </ul>										
2	AC cable	<p>Outdoors five-core copper flexible cable (L1, L2, L3, N, PE)</p> <ul style="list-style-type: none"> <li>• SigenStor EC / SigenStor AC / Sigen Hybrid (5.0–15.0) TP: Cross-sectional area of core conductor: 4–6 mm<sup>2</sup>; Outer diameter: 10–21 mm</li> <li>• SigenStor EC / SigenStor AC / Sigen Hybrid (17.0–20.0) TP: Cross-sectional area of core conductor: 6–10 mm<sup>2</sup>; Outer diameter: 19–22 mm</li> <li>• SigenStor EC / SigenStor AC / Sigen Hybrid 25.0 TP: Cross-sectional area of core conductor: 10–16 mm<sup>2</sup>; Outer diameter: 22–25 mm</li> </ul> <p>Requirements for M5 OT Terminal: Please purchase the OT terminals according to the following requirements.</p> <table border="1"> <thead> <tr> <th>Item</th> <th>Description</th> </tr> </thead> <tbody> <tr> <td>A</td> <td>≤15 mm</td> </tr> <tr> <td>B</td> <td>5.3–5.5 mm</td> </tr> <tr> <td>C</td> <td>≤7.5 mm</td> </tr> <tr> <td>D</td> <td>≤ 26mm</td> </tr> </tbody> </table>	Item	Description	A	≤15 mm	B	5.3–5.5 mm	C	≤7.5 mm	D	≤ 26mm
Item	Description											
A	≤15 mm											
B	5.3–5.5 mm											
C	≤7.5 mm											
D	≤ 26mm											

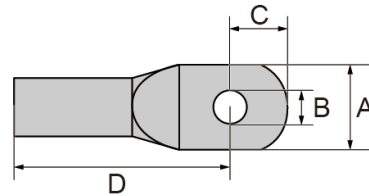

S/N	Cable name	Recommended specifications
3	RS485 signal cable	Outdoor two-core shielded twisted pair Cross-sectional area of core conductor: 0.5–0.75 mm <sup>2</sup> (multi-core flexible conductor, Tubular terminal needed) 0.5–1 mm <sup>2</sup> (single-strand hard conductor, no tubular terminal needed) Outer diameter: 4.5–6.5 mm Cable length: ≤ 1000 m Baud rate: ≤ 9600 bps
4	RJ45 network cable	Outdoor eight-conductor shielded twin-twisted pair cable Cross-sectional area of conductor: 0.13-0.2 mm <sup>2</sup> Outer diameter: 4–7.5 mm Single cable length: ≤ 100 m <sup>[2]</sup>
5	DC cable of inverter (Ignore this cable in case of SigenStor AC inverters)	Outdoor photovoltaic cable Cross-sectional area of core conductor: 4–6 mm <sup>2</sup> Outer diameter: 4.5–7.8 mm

Note [2]: The cable length should be limited for good communication. Too long cable degrades the communication effect. FE communication distance: ≤ 100 m.

## Tips

Recommended specifications for cables connecting power sensors to Distribution panel and to the grid, as well as step-by-step instructions for wiring, can be found in the accompanying documentation for each respective model.



## 3 Site Selection Requirements

---

### Tips

The warranty applies when the equipment has been installed properly for its intended use and in accordance with the operating instructions.

#### Installation environment

- Do not install the equipment in smoky, flammable, or explosive environments.
- Avoid exposing the equipment to direct sunlight, rain, standing water, snow, or dust. Install the equipment in a sheltered place. Take preventive measures in operating areas prone to natural disasters such as floods, mudslides, earthquakes, and typhoons.
- Do not install the equipment in an environment with strong electromagnetic interference.
- Ensure that the temperature and humidity of the installation environment comply with the equipment's requirements.
- The equipment should be installed in an area that is at least 500 m away from corrosion sources that may result in salt damage or acid damage (corrosion sources include but are not limited to seaside, thermal power plants, chemical plants, smelters, coal plants, rubber plants, and electroplating plants).

#### Installation position

- Do not tilt or overturn the equipment to ensure that it is installed horizontally.
- Do not install the equipment in places easily touched by children.
- Do not install the equipment in places with fire or damp.
- Please keep away from the daily work and living places.
- Do not install the equipment in a sealed, poorly ventilated location without fire protection measures and difficult access for firefighters.
- The equipment is hot when it is running. If the equipment is installed indoors, please ensure good indoor ventilation and avoid significant indoor temperature rise by 3°C while the equipment is running. Otherwise, the equipment will be derated.
- Do not install the equipment in mobile scenarios such as RVS, cruise ships, and trains.
- You are advised to install the equipment in a location where you can easily access, install, operate, maintain it, and view the indicator status.
- When installing the equipment in the garage, do not install the equipment in the position where the vehicle passes through to avoid collision.

## Mounting surface

- Do not install the equipment on a flammable installation base.
- The installation base should meet the load-bearing requirement. Solid brick-concrete structures, concrete walls, and floors are recommended.
- The surface of the installation base must be smooth and the installation area must meet the installation space requirements.
- No water or electricity is routed inside the installation base to prevent drilling hazards during equipment installation.

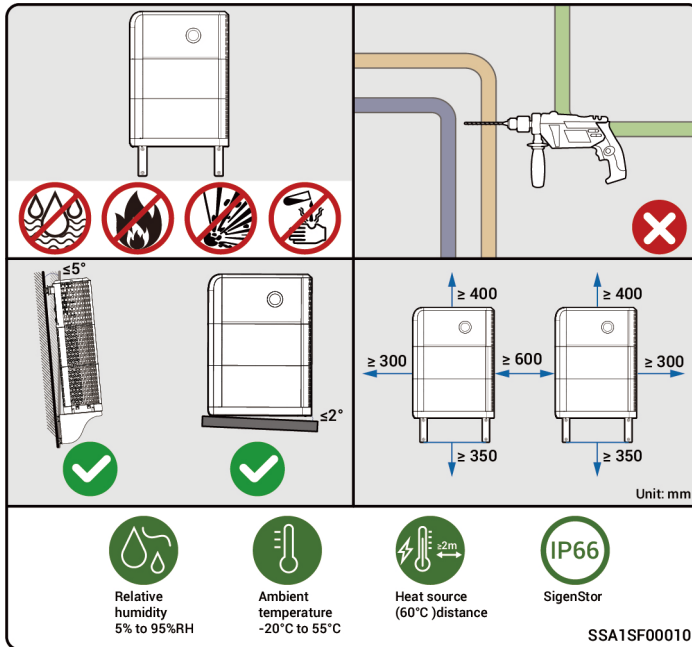

## 4 Installation of inverter and battery pack

### Tips

- Up to six SigenStor BATs are supported for floor installation and up to two for wall installation.
- When installing three or more SigenStor BATs on the floor, use Lift.
- Multiple SigenStor BATs can be installed onsite based on the actual configuration.
- If the floor is prone to stagnant water, please set up a waterproofing platform or install it on the wall.
- The equipment is heavy, do not slip off when handling the equipment to avoid the equipment falling and injuring the operator.
- SigenStor BAT is forbidden to be used after falling, please buy a new one.
- Do not drag the equipment during installation.

### 4.1 Floor Mounting

- 1 If the bubble level is not centered, use a Leveling plate to adjust.

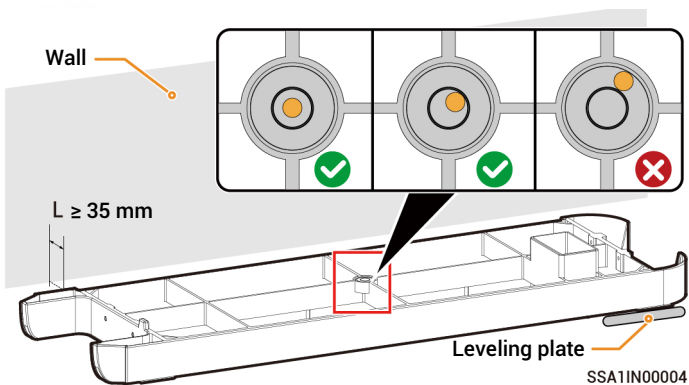

- 2 There are two installation methods for the Base. Please refer to the actual product received for detailed instructions.

#### Option 1

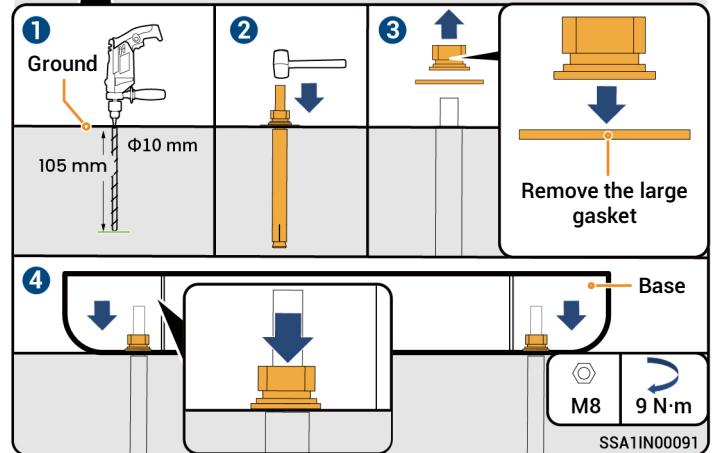
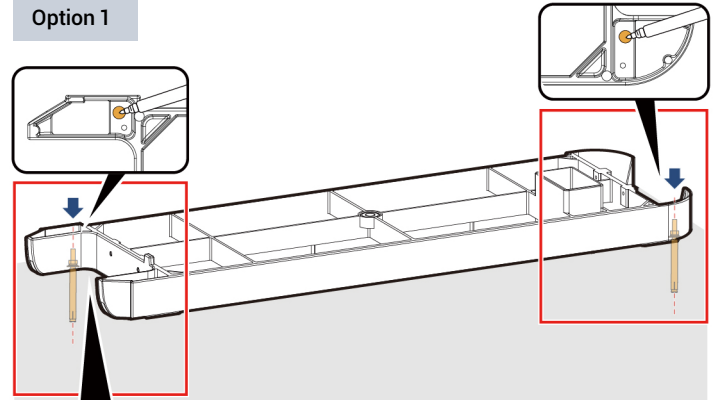

Option 2

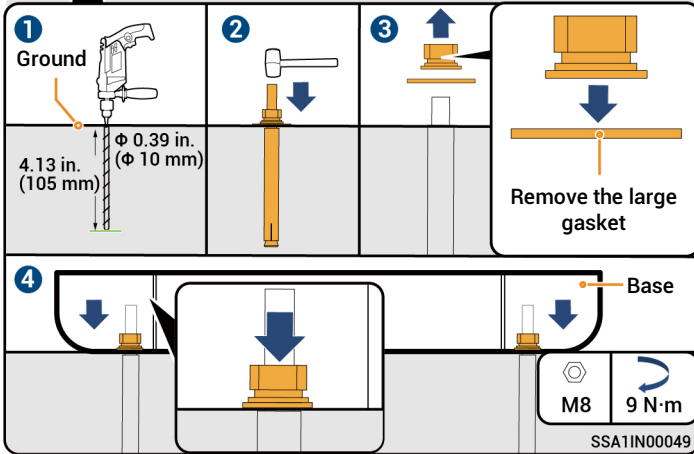
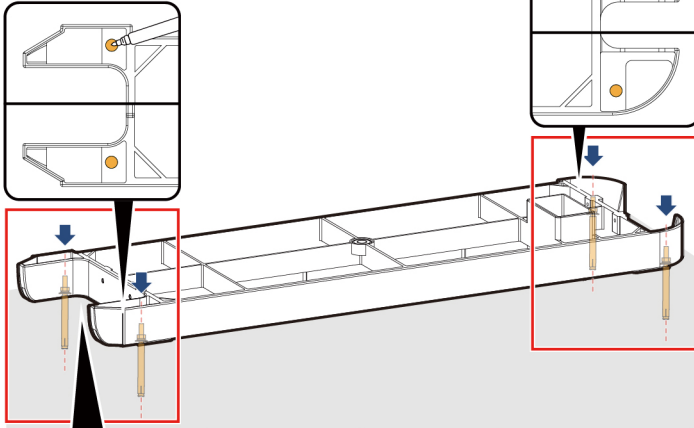

3 INV1 is the mounting hole on the left side of the inverter for wall installation, while INV2 is the mounting hole on the right side for wall installation.

Calculation formula for punch height:

L1 and L2 should be measured from the upper surface of the base:

$$L1 = N \times 270 \text{ mm} + 261 \text{ mm} \pm 3 \text{ mm}$$

$$L2 = N \times 270 \text{ mm} + 254 \text{ mm} \pm 3 \text{ mm}$$

Note: N is the number of SigenStor BATs and N ranges from 3 to 6.

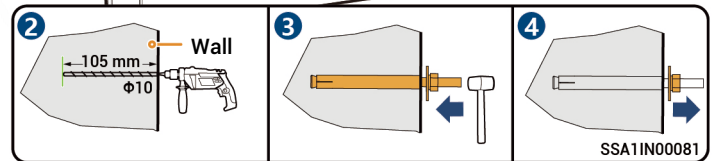
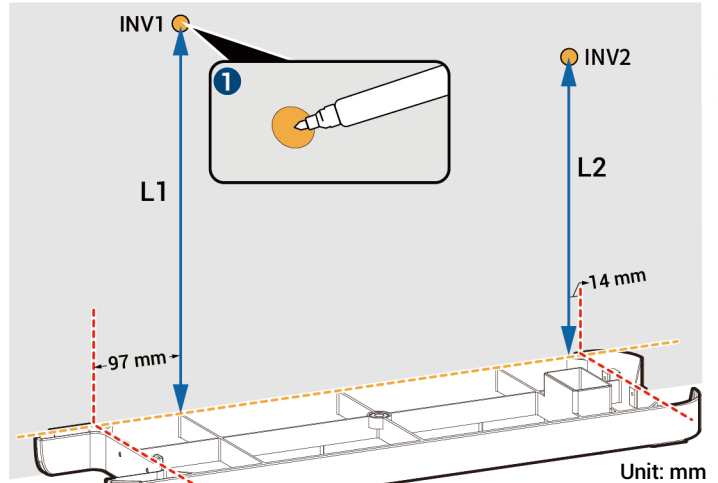

**4** Before installing the handle, please use a Torque socket wrench to measure the screws and confirm that the screws on Sigen BAT are securely tightened with a torque of 4.5 N·m ( $\pm 0.45$  N·m).

**Caution**

- Use the new handle supplied with the inverter for your installation operation.
- The "OUT" lettering on the handle must face outwards.
- Do not use a handle with stoppers that fell off or damaged for your installation operation. (Including but not limited to rust, paint peeling, deformation, and fracture)
- The handle is a personal asset of the owner. After use, it must be handed over to the owner for future use and must not be taken away from the installation site.
- The handle shall not be used more than 100 times. The handle that exceeds the use limits shall be scrapped.

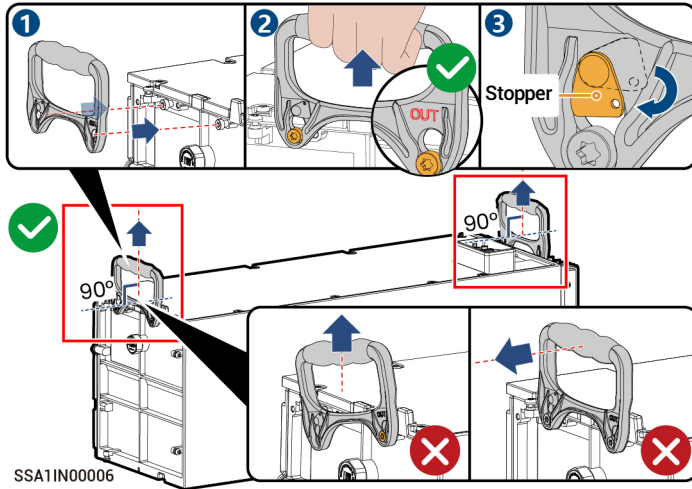

SSA1IN00006

**5** SigenStor BAT is kept horizontally and mounted vertically downwards.

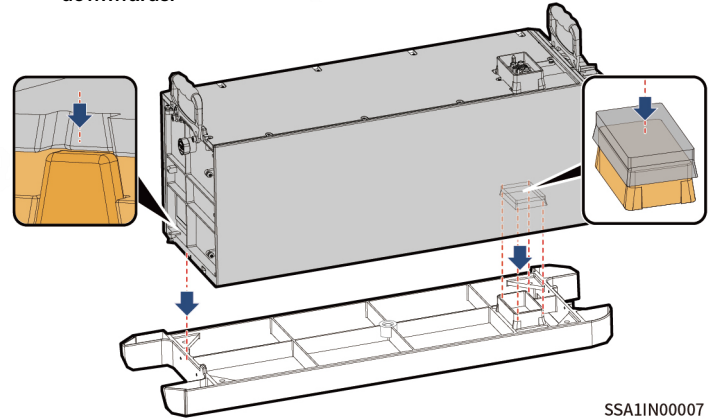

SSA1IN00007

**6** For details about how to place the second SigenStor BATs, see Steps **4** **5** .

**7** If three or more SigenStor BATs are to be installed, use a Lift. For details about the hoisting rope binding scheme, see the figure.

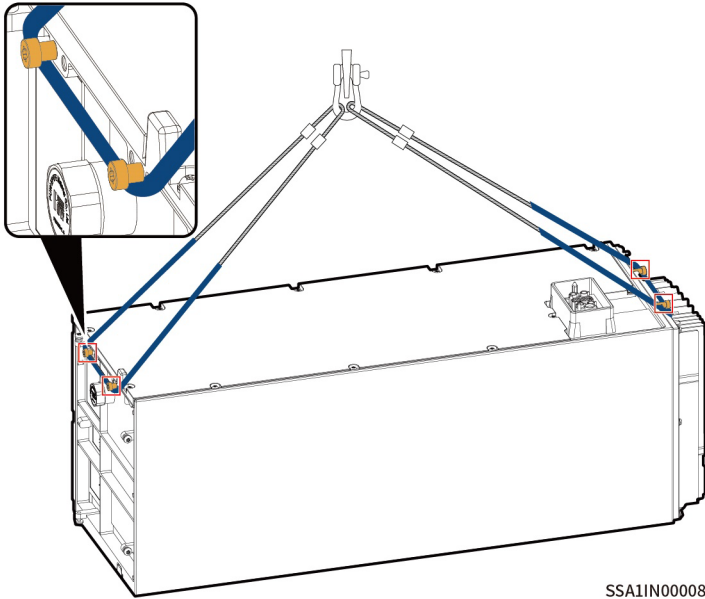

### Tips

During lifting operations, the area where the sling comes in contact with the equipment should be wrapped with a protective layer to avoid damage to the equipment.

**8** Arrange SigenStor EC, SigenStor AC or Sigen Hybrid.

SigenStor EC or SigenStor AC

For details, see Step **5**.

Sigen Hybrid

Remove the IP protection cover at the bottom.

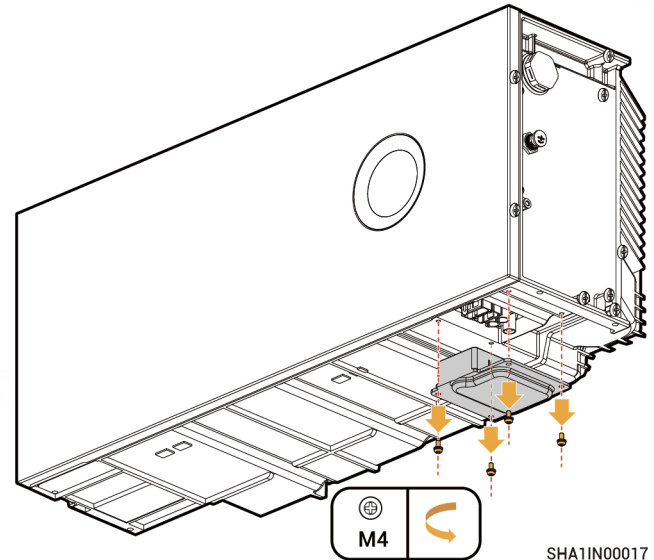

Install the chuck screws of the decorative parts, and arrange them as described in Step 5.

## Tips

The chuck screws are packed in the extension package.

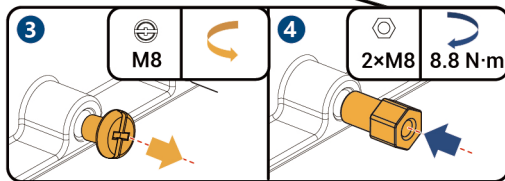
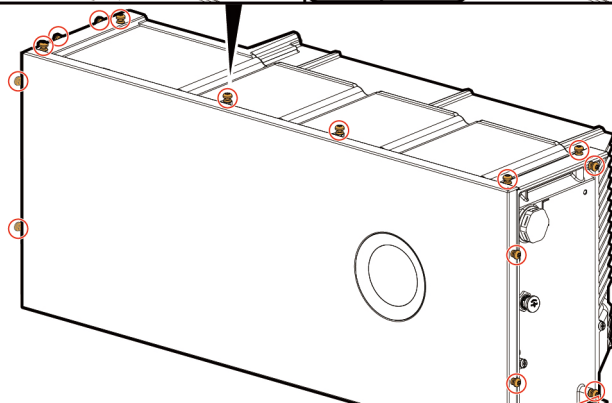
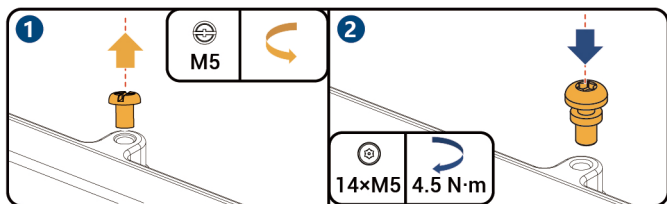

SHA1IN00010

9 Base bracket has two versions in terms of appearance. The actual product shall prevail. The installation method for both versions remains the same.

### Appearance 1

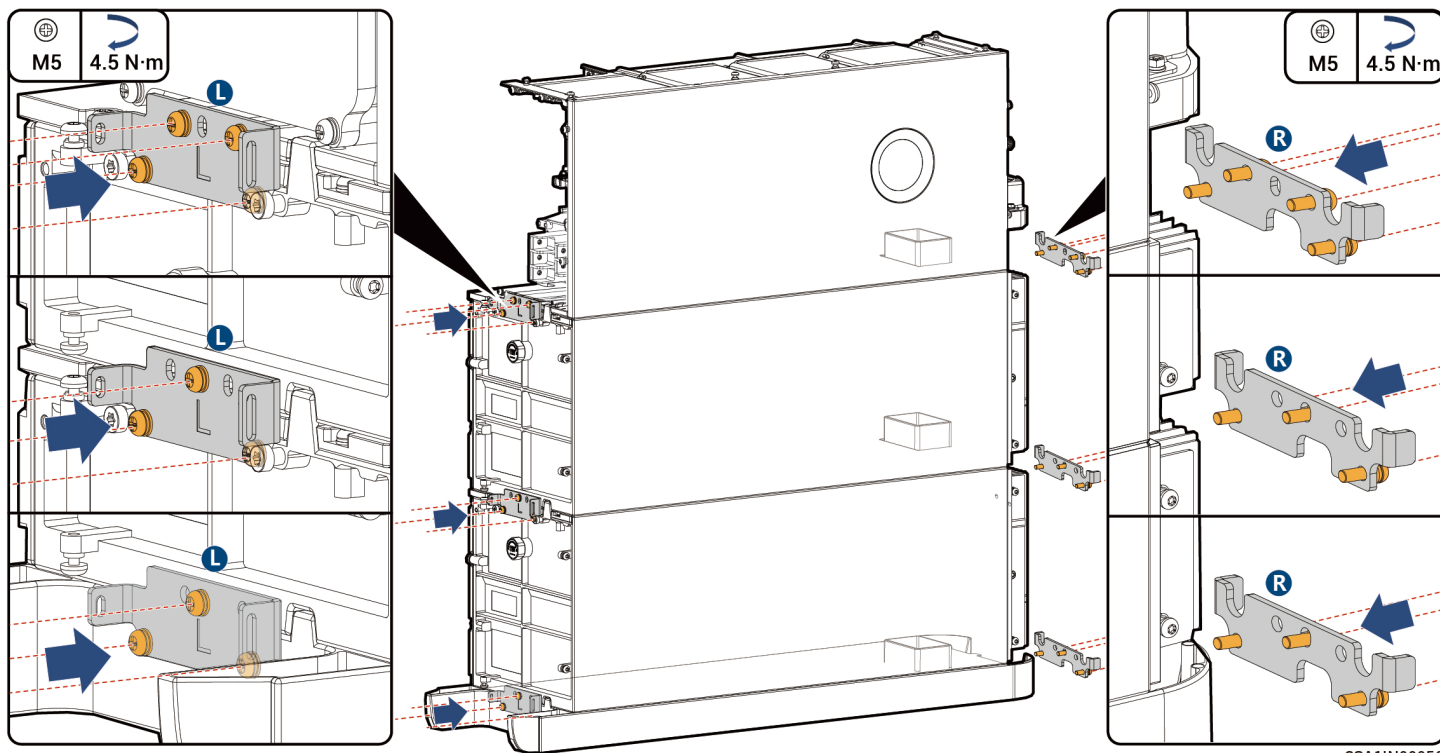

SSA1IN00050



Appearance 2

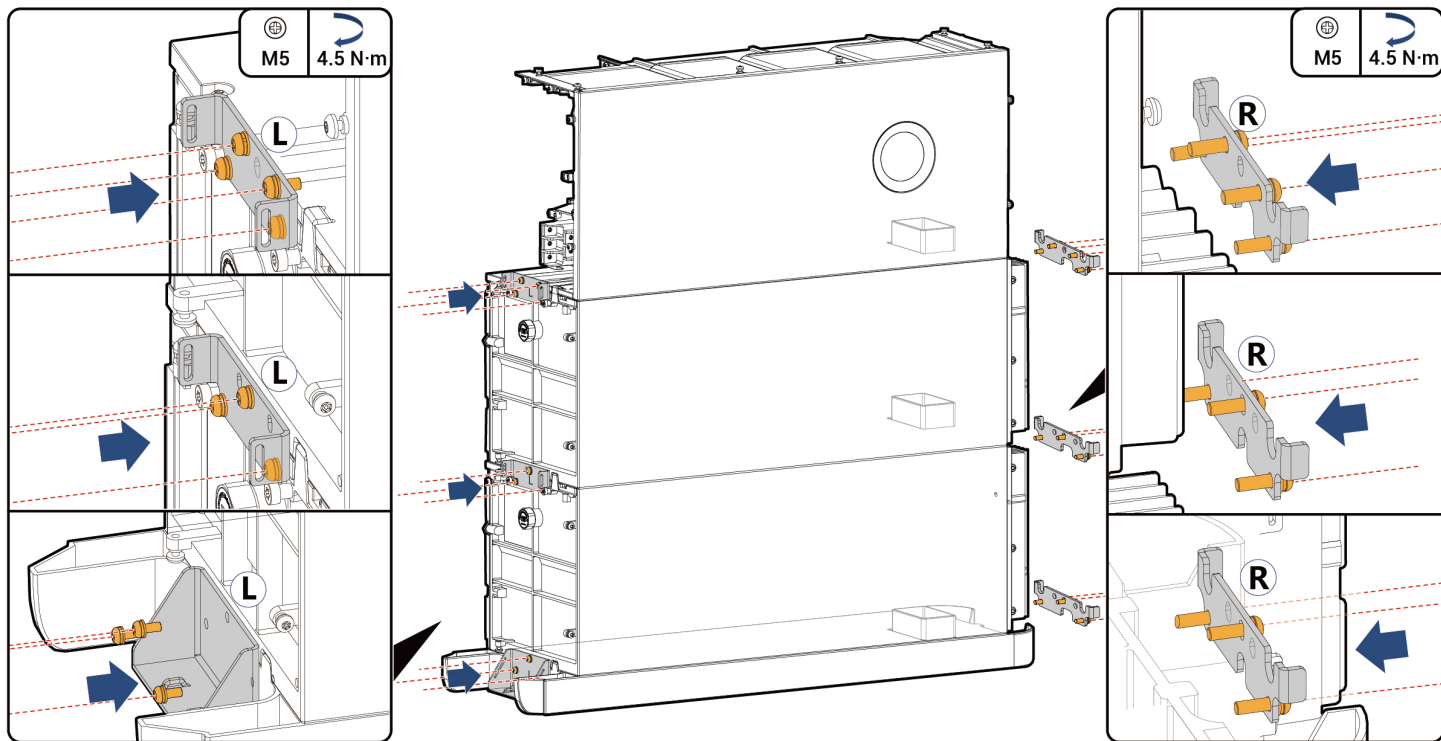

SSA1IN00050

**10** Steps **3** and **4** are optional and can effectively prevent theft.

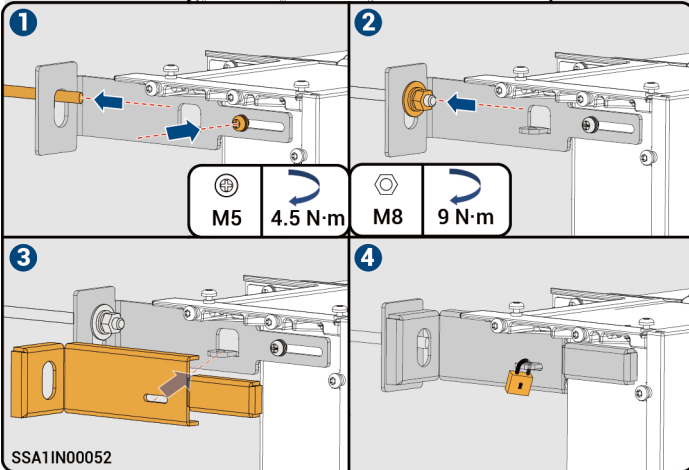
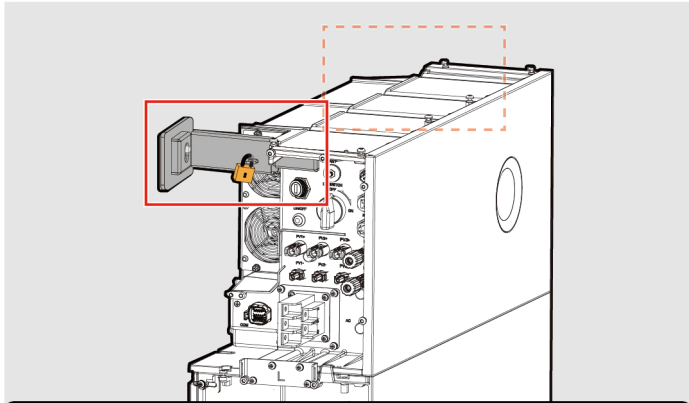

## 4.2 Wall Mounting

- 1** There are two installation methods for the Angle Bracket. Please refer to the actual product received for detailed instructions.

Option 1

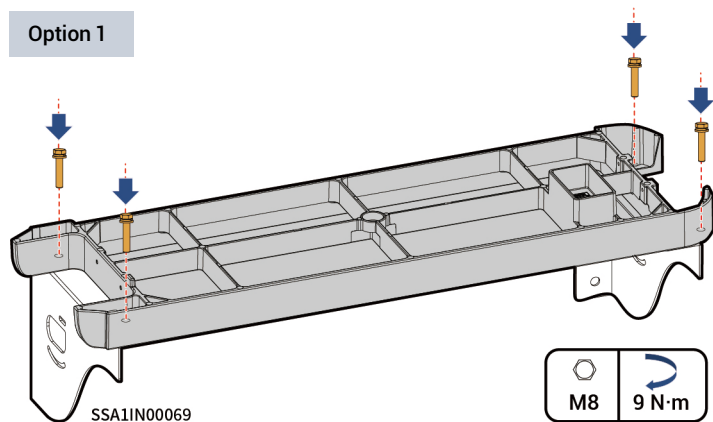

Option 2

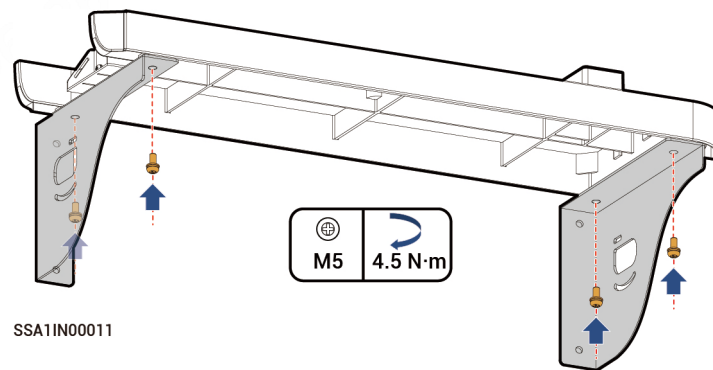

**2**

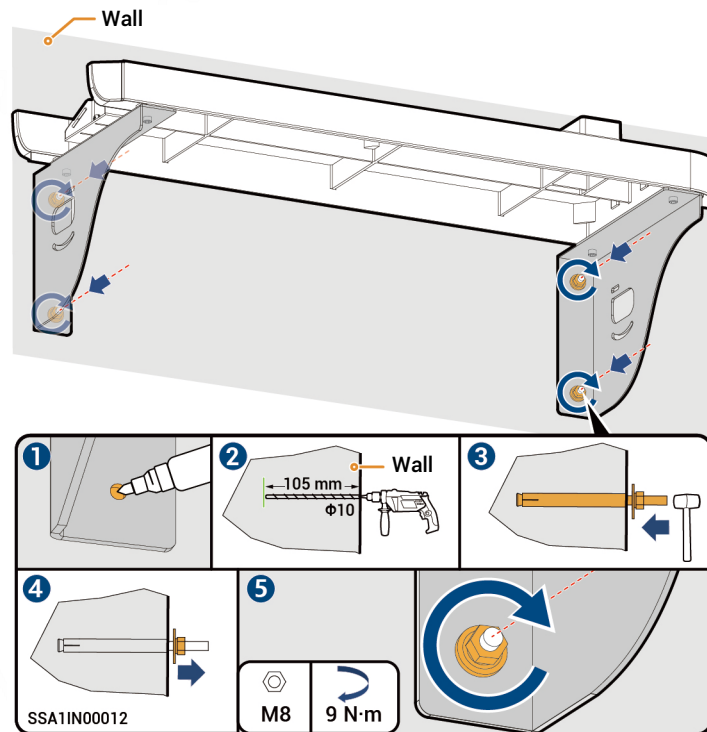

**3**

Calculation formula for punch height:

L1 and L2 should be measured from the upper surface of the base:

$$L1 = N \times 270 \text{ mm} + 261 \text{ mm} \pm 3 \text{ mm}$$

$$L2 = N \times 270 \text{ mm} + 254 \text{ mm} \pm 3 \text{ mm}$$

Note: N is the number of SigenStor BATs and N is 1 or 2.

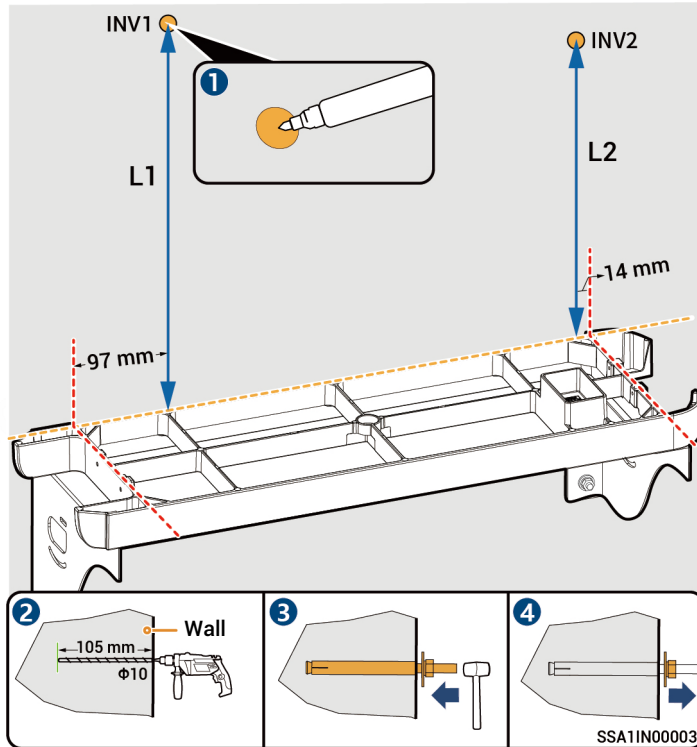

**4** For details about how to place the SigenStor BAT, see Steps **4** **5** in Section 4.1 Floor installation.

**5** For details about how to place the inverter, see Steps **8** in Section 4.1 Floor installation.

**6** For the installation of the Base bracket, please refer to Step **9** in Section 4.1 Floor Installation.

**7** For the installation of the fasteners for a wall-mounted inverter, please refer to Step **10** in Section 4.1 Floor installation.

## 5 Cable Connection and Component Installation

### Danger





- Before connecting cables, ensure that DC SWITCH is in the OFF state, and the front switch of the AC line is off.
- Do not perform operations on the equipment with power on. Before operation, please make sure all power supplies to the equipment have been disconnected, including but not limited to the grid side, inverter and diesel generator power switches.

### Tips

- The cable colors in the figure are used only to distinguish different lines. The cable colors are based on actual conditions.
- Bind the power cable separately from the signal cable.
- There are three routing schemes, Select them based on the actual situation.
- PVC wiring ducts or PVC conduits are recommended to wrap cables outside decorative parts. 60 × 50 mm PVC wiring ducts are recommended and PVC conduits with diameter not less than  $\Phi 80$  are recommended.

### 5.1 Recommended Cabling installation

#### Scheme I

-  AC output cable
-  RS485 signal cable
-  Protective ground cable
-  RJ45 cable
-  DC input cable

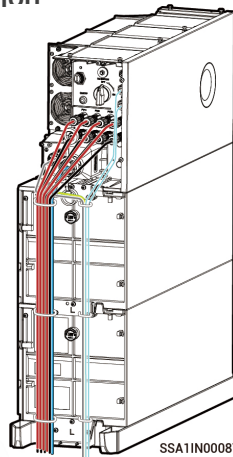

#### Scheme II

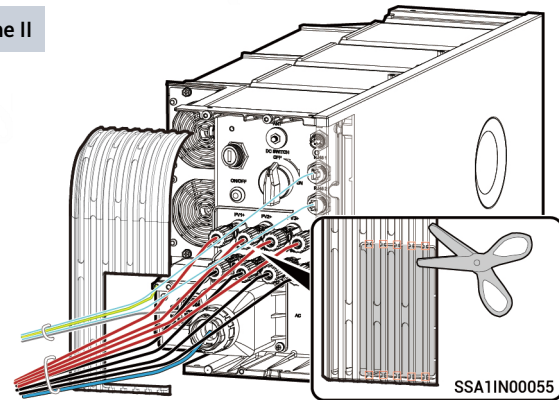

#### Scheme III

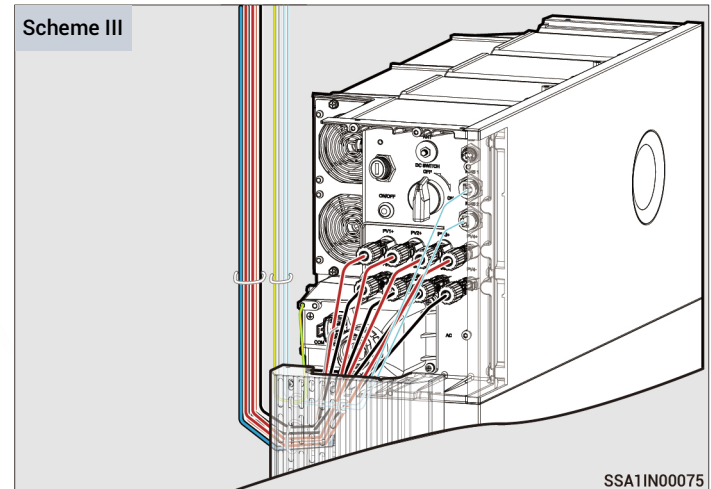

## 5.2 Protective Ground Cable of Inverter

### Tips

The protective ground wire should be grounded in close proximity.

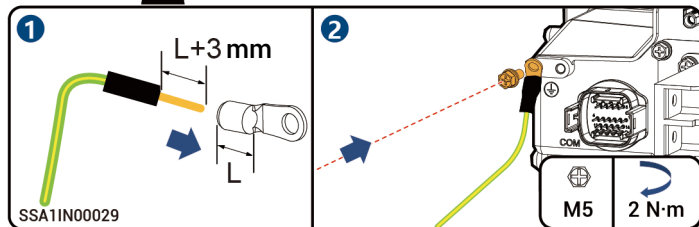
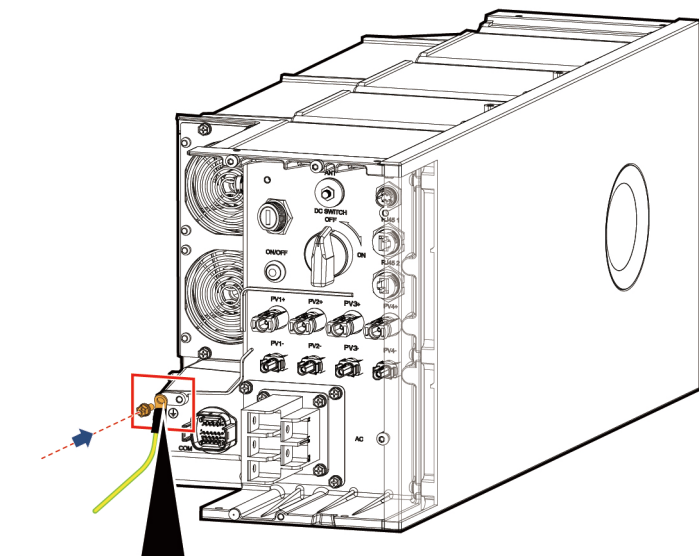

## 5.3 AC Output Cable of Inverter

### Tips

The AC interface on the inverter is available in three appearances, Please select the appearance as needed.

#### Appearance 1

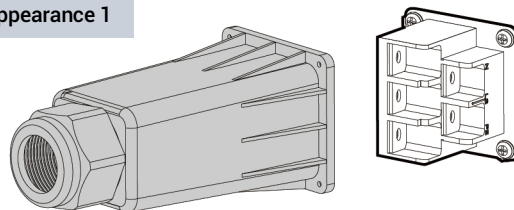

#### Appearance 2

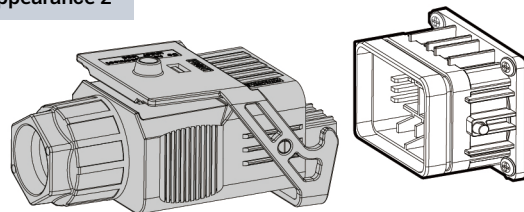

#### Appearance 3

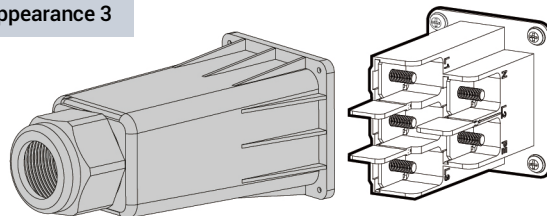

SSA11N00114

## Appearance 1

### ⚠ Caution

Only SigenStor EC / SigenStor AC / Sigen Hybrid (15.0 – 25.0) TP requires cold shrink tube.

#### 1 Unit: mm

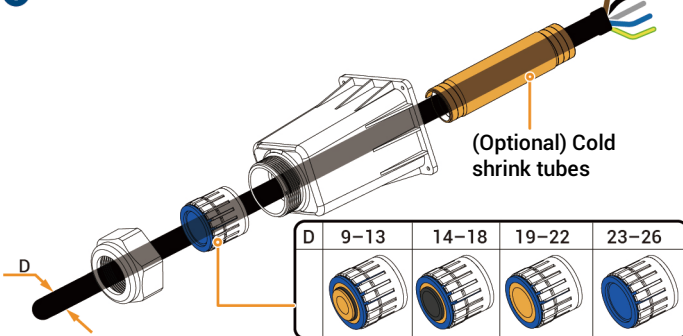

#### 2 SigenStor EC / SigenStor AC / Sigen Hybrid (5.0 – 12.0) TP :

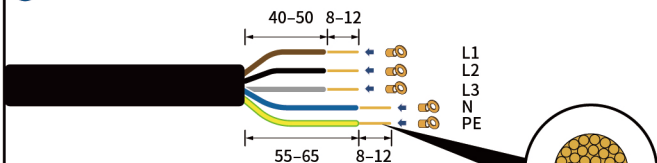

#### SigenStor EC / SigenStor AC / Sigen Hybrid (15.0 – 25.0) TP:

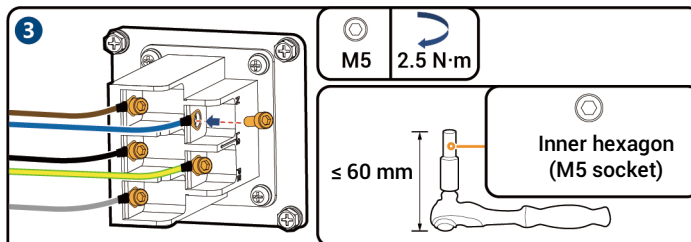
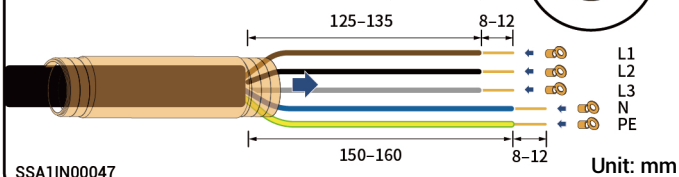

#### 4 (Optional)

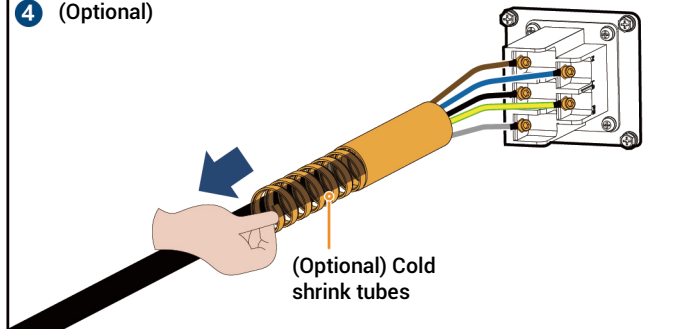

#### 5

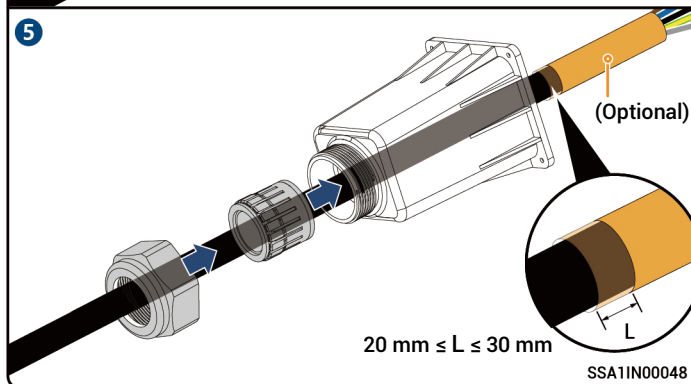

SSA1IN00047

SSA1IN00048

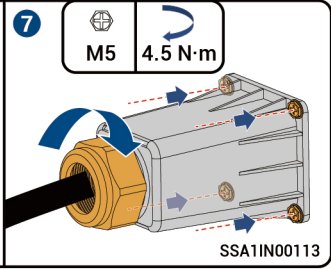
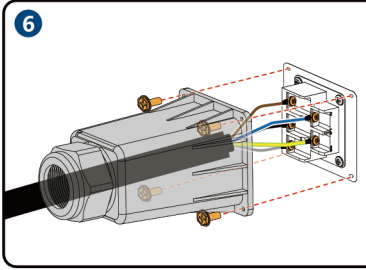
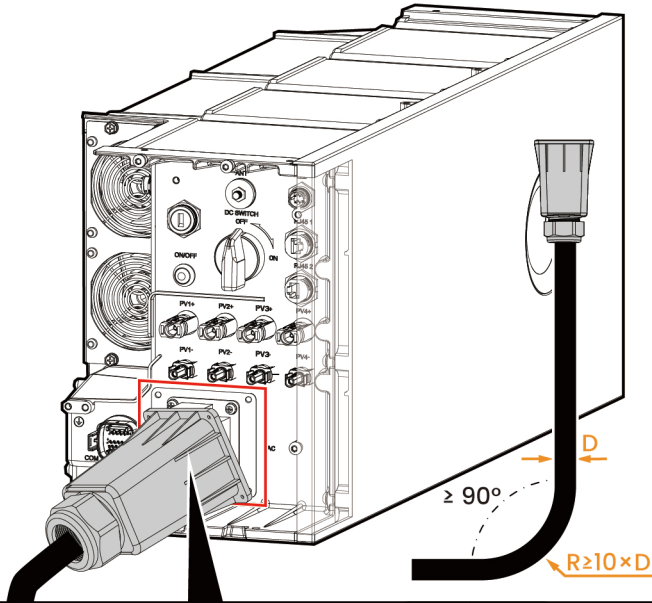



## Appearance 2

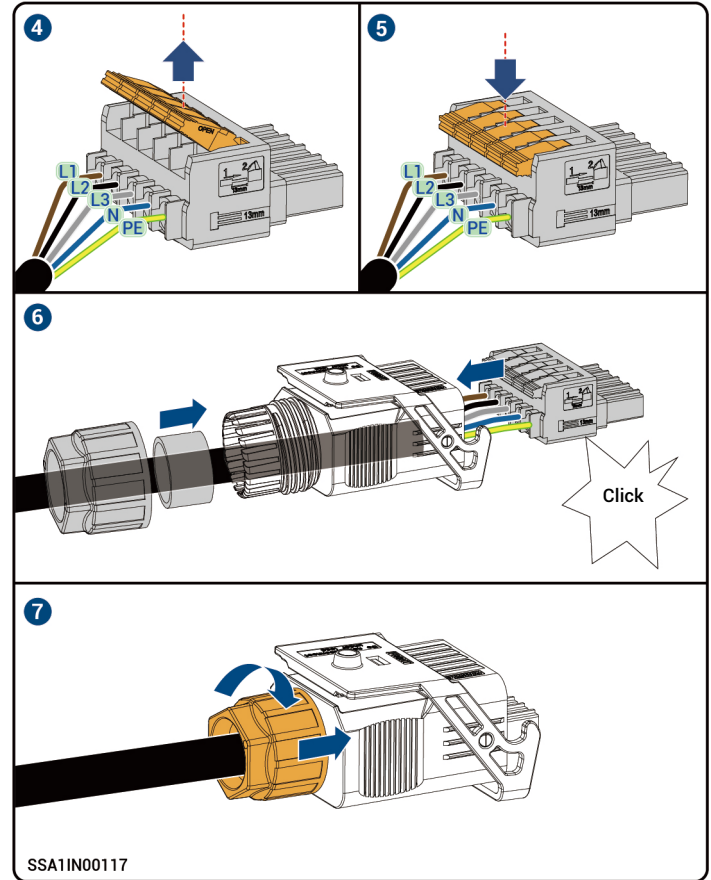
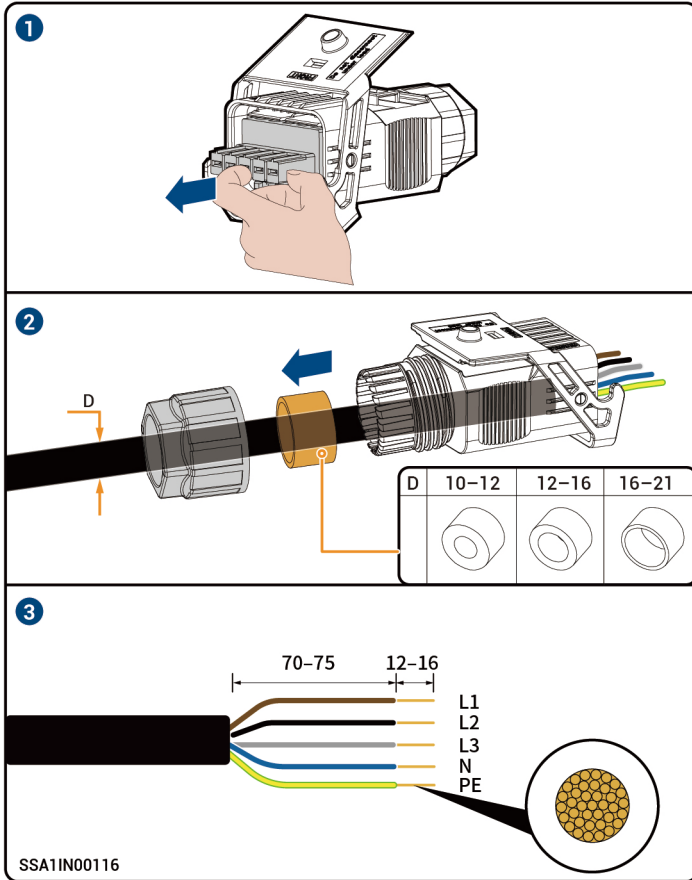

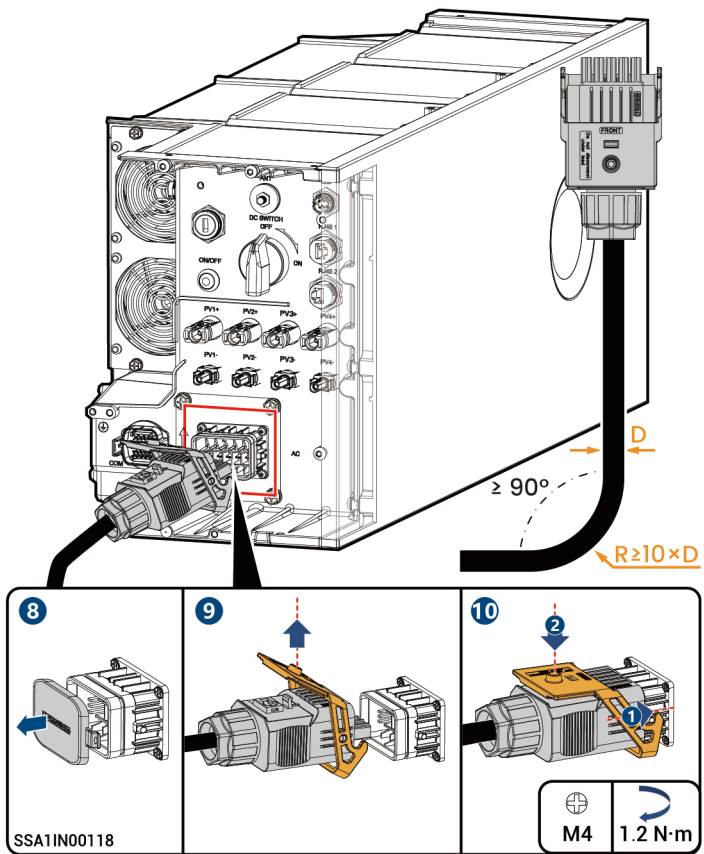

Appearance 3

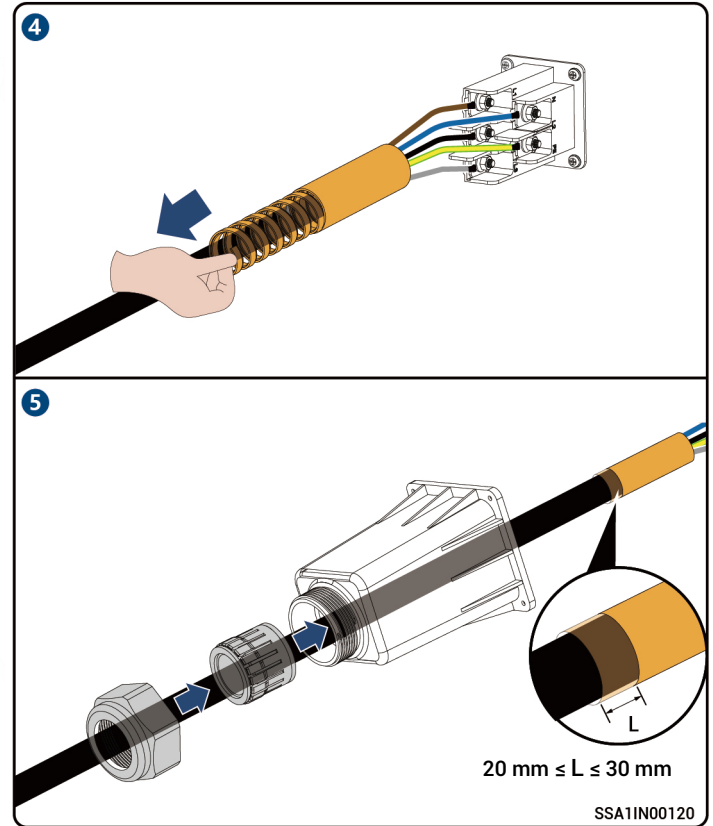
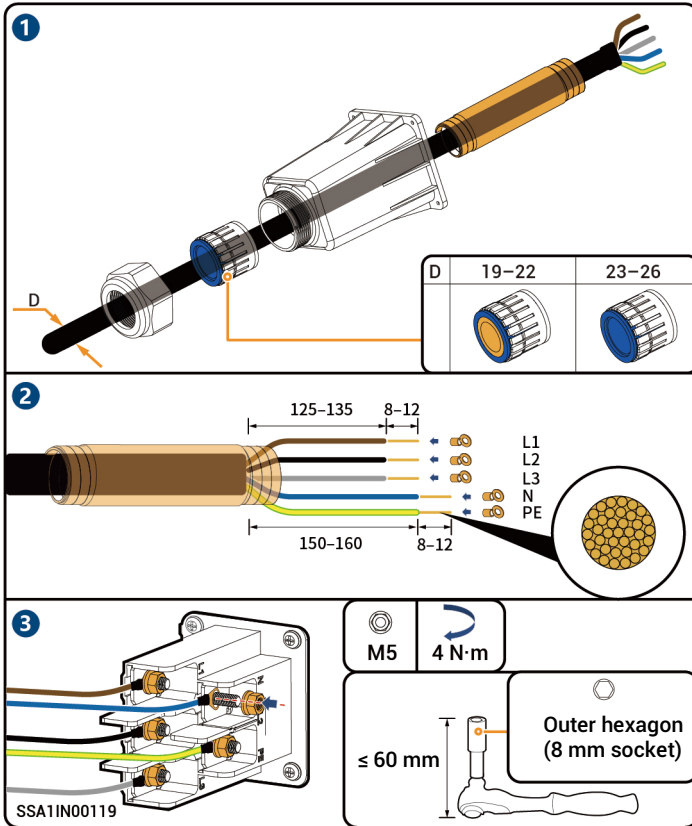

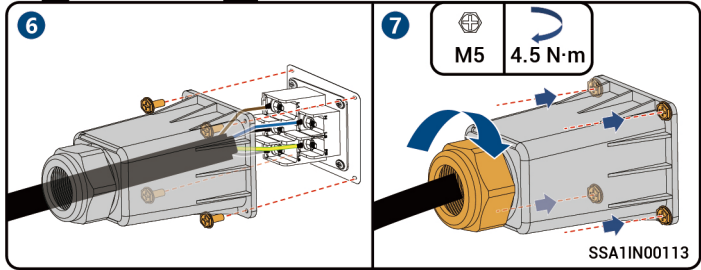
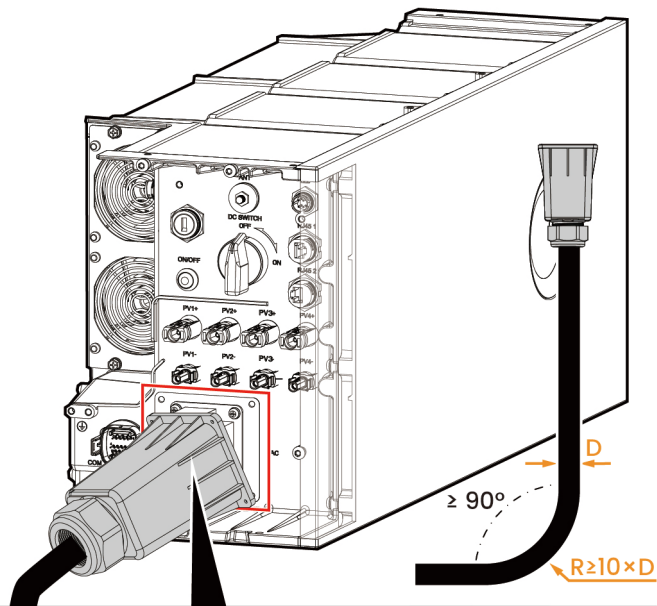

## 5.4 COM terminal of the inverter introduction

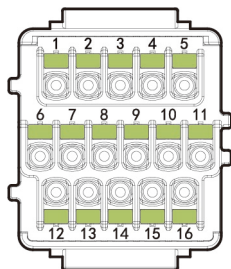

### Tips

- The power sensor needs to be purchased from our company's official channels.
- The appearance and specific wiring of the power sensor can be found in the instruction manual delivered with the case.

Description	Interface definition	COM terminal of the inverter	Sigen Sensor TP-DH(SDM630MODBUS V2)	Sigen Sensor TP-CT120-DH(SDM630 MCT 40mA/120A)	Sigen Sensor TP-CT300-DH(SDM630MCT 40mA/300A)	Sigen Sensor TP-CT600-DH(SDM630MCT V2/600A)
(Reserved) DO1, connected to third party intelligent electric equipment, such as switch control and heat pump	Dry contact 1 – Common	1	-	-	-	-
	Dry contact 1 – NO	2	-	-	-	-
(Reserved) DO2, connected to third party intelligent electric equipment, such as switch control and heat pump	Dry contact 2 – Common	3	-	-	-	-
	Dry contact 2 – NO	4	-	-	-	-
(Reserved) For power scheduling, such as DRM and Ripple Control Receiver	DI1, digital input 1	5	-	-	-	-
	DI2, digital input 2	6	-	-	-	-
	DI3, digital input 3	7	-	-	-	-
	DI4, digital input 4	8	-	-	-	-
	Signal GND	10	-	-	-	-
(Reserved)	DI5, digital input 5	9	-	-	-	-
RS485-2, COM port used to access the power sensor	PE signal shielding ground	12	-	-	-	-
	RS485 signal 2_B-	13	B-	13	13	13
	RS485 signal 2_A+	14	A+	14	14	14
RS485-1, custom port. Used to connect a third-party EMS controller, an electric meter, or a heat pump.	PE signal shielding ground	11	-	-	-	-
	RS485 signal 1_A+	15	-	-	-	-
	RS485 signal 1_B-	16	-	-	-	-

## 5.4.1 RS485 Signal Cable of inverter

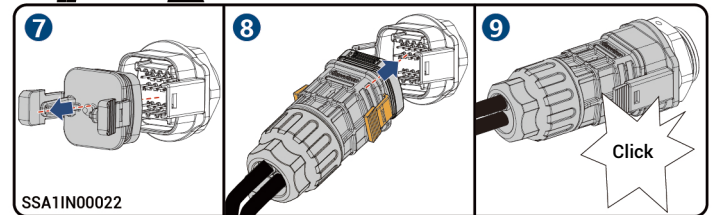
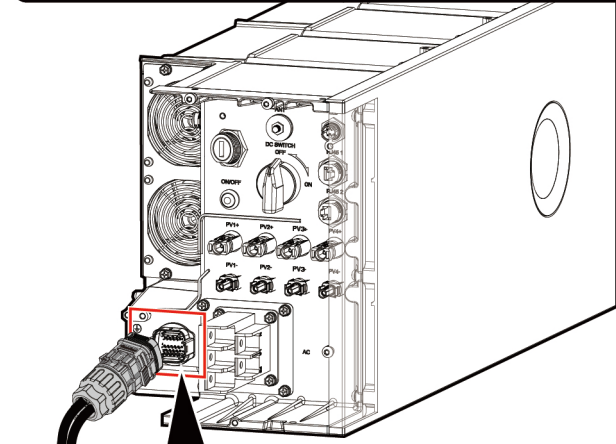
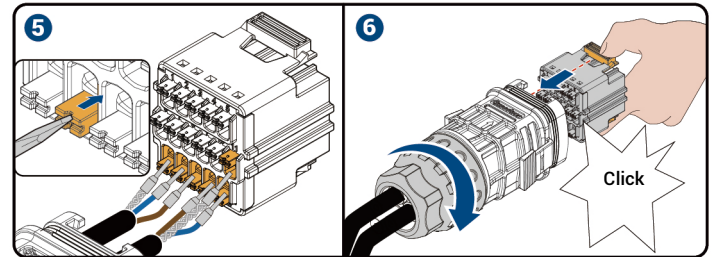
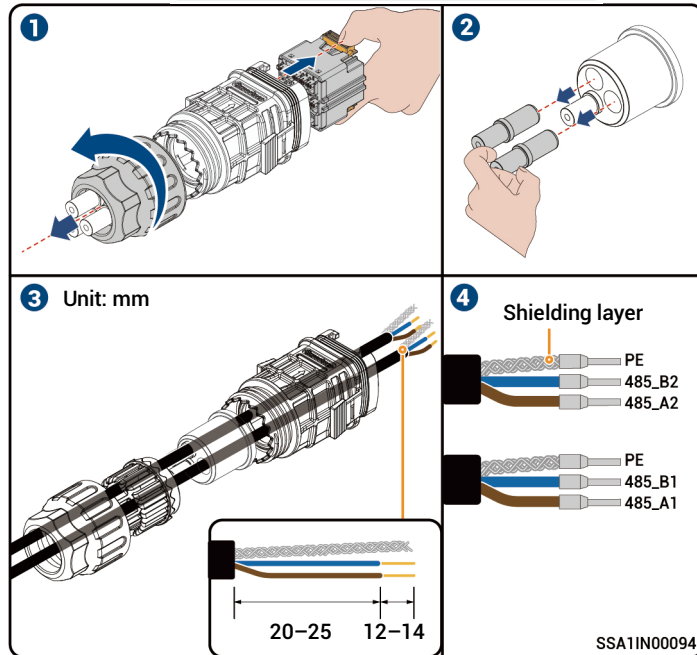
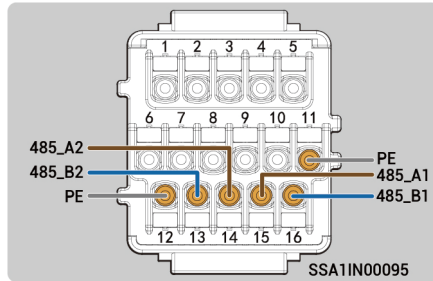

## 5.4.2 (Optional) Ripple Control Receiver connection

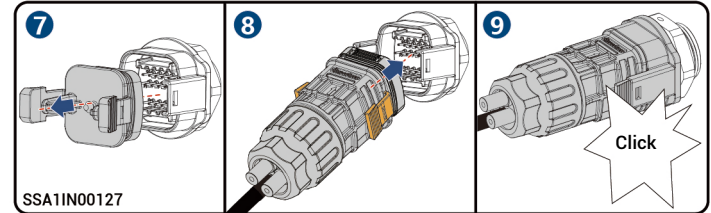
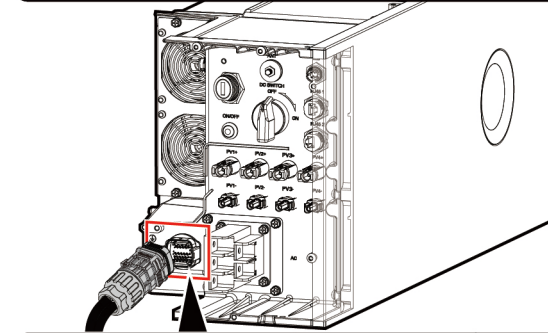
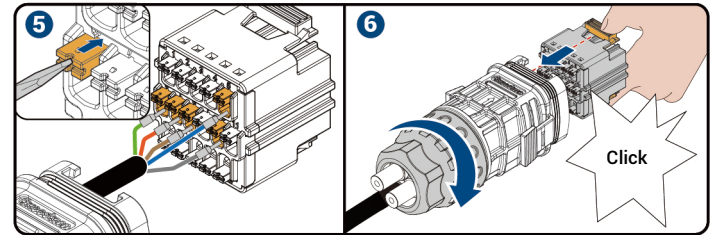
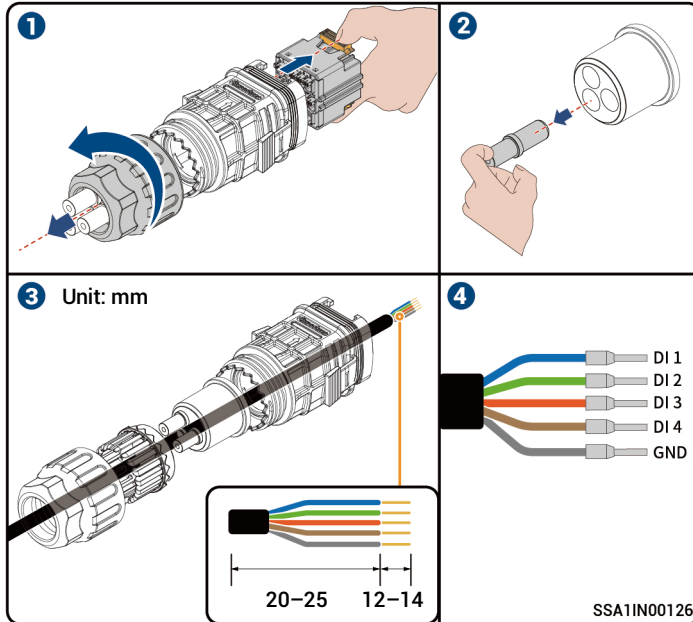
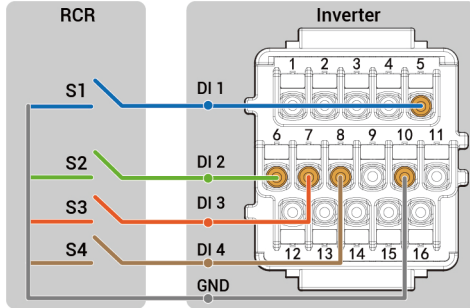

### Tips

After creating new systems, you can use the mySigen App to set the parameters for Active Dry Contact scheduling or Reactive Dry Contact scheduling. For specific operation steps, please refer to Chapter 2.3 of the mySigen App Installer Manual.

## 5.5 DC input cable of inverter

### Tips

- Please make sure that the circuit breaker on the PV side is electrically neutral before connection.
- The DC cable is connected to the inverter from the PV string. Ignore this section in case of SigenStor AC inverters.

**1** Positive metal terminal

8-10 mm

Negative metal terminal

**2**

**3** Positive connector

Negative connector

**4**

SSA1IN00024

**5**

**6**

SSA1IN00089

### Caution

- If the voltage is negative, the polarity is incorrect. Rectify the fault in time.
- Please select the PV strings according to the product specifications listed in the table.

Product model	PV string formation configuration
SigenStor EC / SigenStor AC / Sigen Hybrid (5.0–8.0) TP	connected with 2 channels of strings(PV1+/PV2+/PV1-/PV2-)
SigenStor EC / SigenStor AC / Sigen Hybrid (10.0–15.0) TP	connected with 3 channels of strings(PV1+/PV2+/PV3+/PV1-/PV2-/PV3-)
SigenStor EC / SigenStor AC / Sigen Hybrid (17.0–25.0) TP	connected with 4 channels of strings (PV1+/PV2+/PV3+/PV4+/PV1-/PV2-/PV3-/PV4-)



## 5.6 RJ45 Cable of inverter

### Tips

- RJ45 cables are EIA/TIA 568B standard cables.
- Two RJ45 Ethernet ports, one is connected to the router, and the other is connected to other equipment.(e.g., inverter, Gateway etc.)

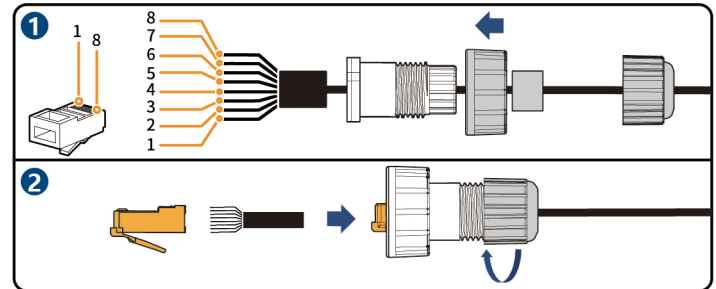
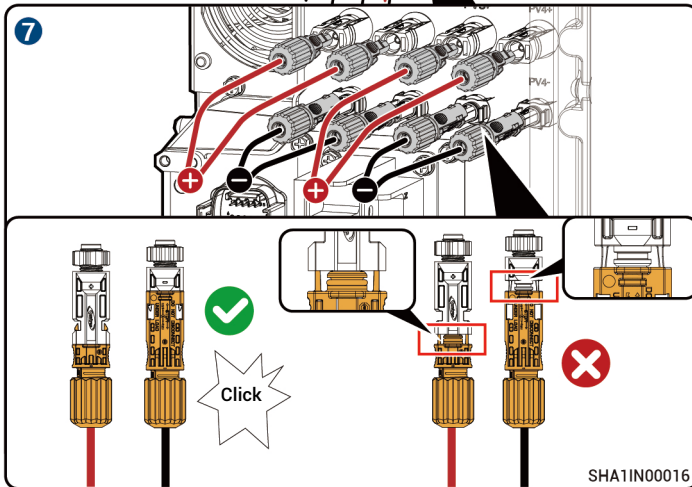
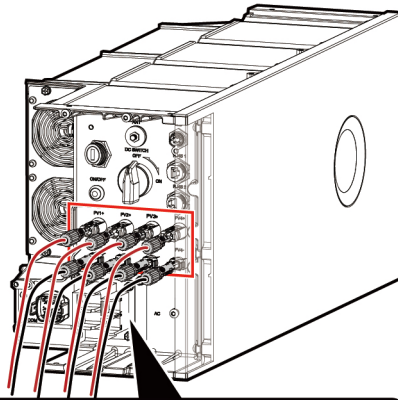

- ① White orange
- ② Orange
- ③ White green
- ④ Blue
- ⑤ White blue
- ⑥ Green
- ⑦ White brown
- ⑧ Brown

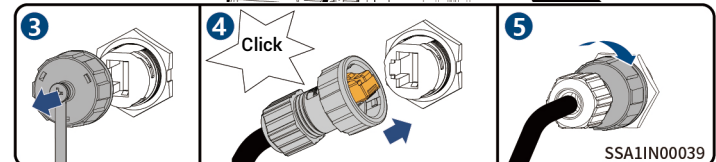
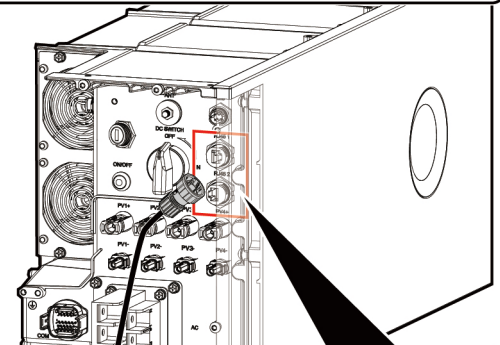

## 5.7 (Optional) Replacing SIM card of Sigen CommMod

### Tips

- Skip this step when a single inverter is installed.
- You must replace the SIM card in Sigen CommMod with a SIM card of your country or region when multiple inverters are installed.
- Recommended data plan:  $\geq 50 \text{ MB/month} \times N$ . (Wherein, N is the number of inverters)
- If you hear only one click sound when assembling Sigen CommMod in Step ③, complete the assembly on the other side.

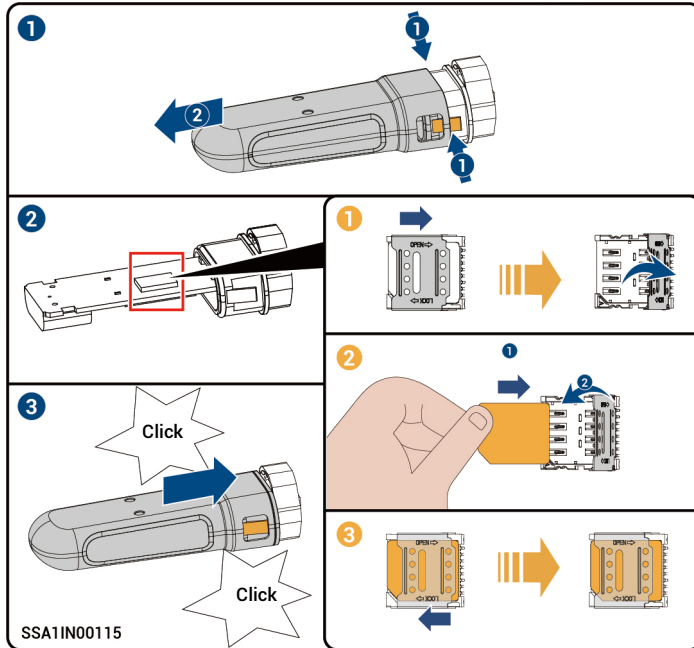

## 5.8 Sigen CommMod Installation

### Tips

Sigen CommMod is required for 4G communication.

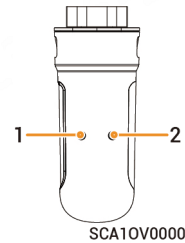

S/N	Indicator	Description
1	Power indicator	-
2	Network state indicator	<ul style="list-style-type: none"> <li>• Slow flashing(200 ms on/1800 ms off): The network is being connected</li> <li>• Slow flashing(1800 ms on/200 ms off): Standby</li> <li>• Quick flashing(125 ms on/125 ms off): Data is being transferred</li> </ul>

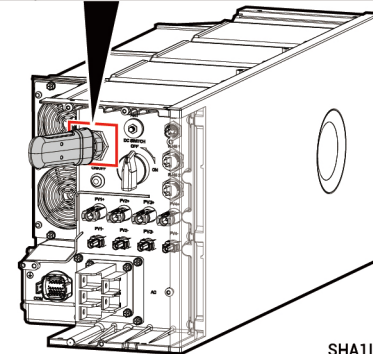
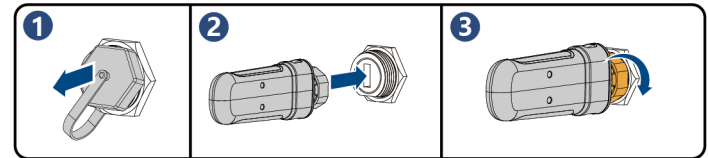

SHA1IN00014

## 5.8 WLAN antenna stick Installation

### Tips

- WLAN communication requires the installation of WLAN antenna stick.
- To ensure good communication, tighten the antenna rod up clockwise. The antenna rod is tightened up when it cannot be easily turned counterclockwise.

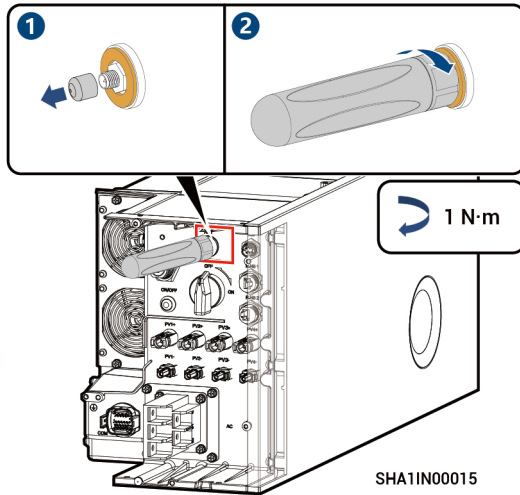

## 6 Post-installation Check

S/N	Check Item
1	The equipment has been securely installed.
2	Ground cables, DC cables, signal cables, etc. are installed accurately without leftovers.
3	The cable fastening screws or terminals are properly installed.
4	There are no sharp spikes or acute angles at the cut point of the cable tie.
5	DC SWICH is in the OFF state.
6	Ports that are not in use have waterproof covers or plugs installed.
7	There is no construction left inside or outside the equipment.

After confirmation, install the SigenStor BAT and SigenStor EC /SigenStor AC/Sigen Hybrid decorative covers.

## 7 Installation of the Decorative Cover

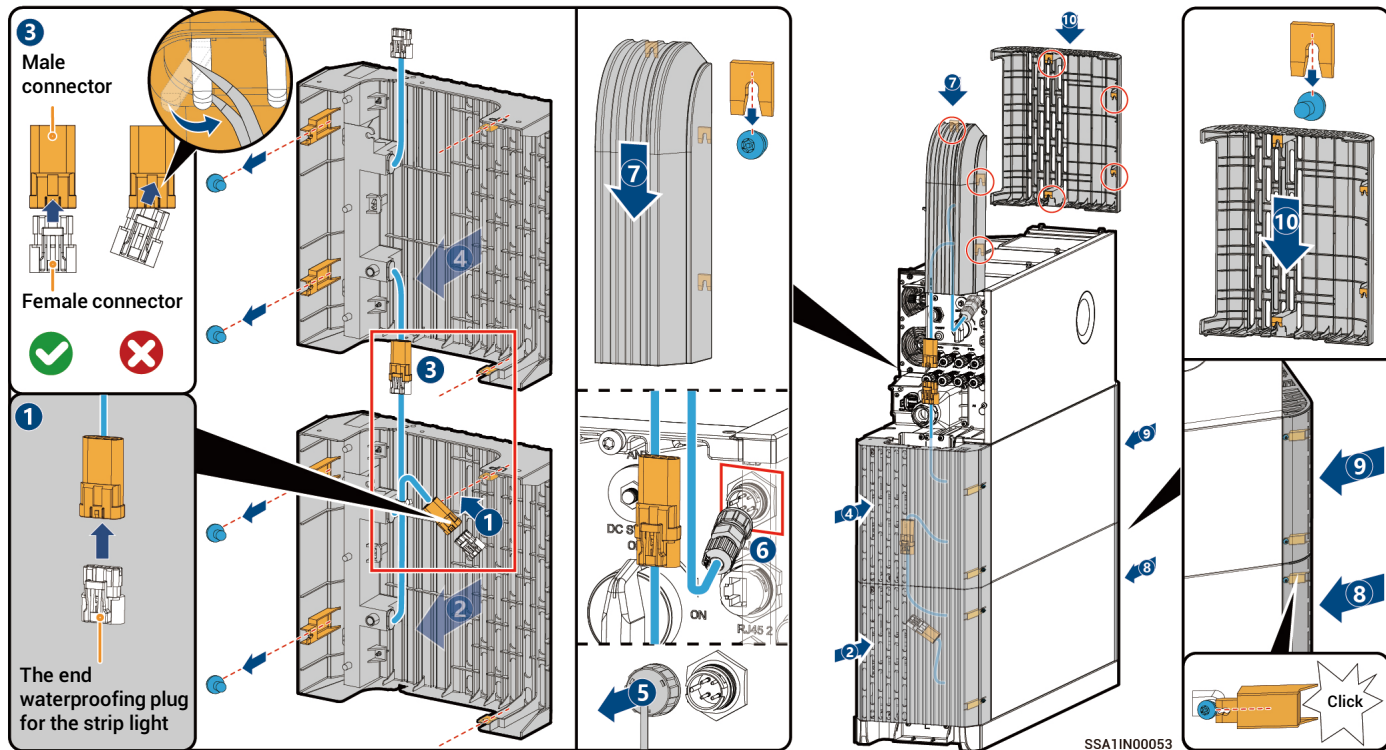

### ⚠ Caution

- The end waterproofing plug for the strip light in step **1** is at the lower end of the decoration on the left side of the inverter, please remove it for spare.
- If the strip light display is abnormal after the device is power-on, please check whether the pin in the male connector is tilted. If it is tilted, please correct it. And then to unplug and re-plug the male and female connectors at the abnormal location, or unplug and re-plug the terminals in the step **6** to resume operation.

## 8 Equipment Power-On

1. Turn on the upstream switch of equipment.
2. Rotate DC SWITCH to ON. (This step is not necessary for SigenStor AC)
3. Observe the indicators on the front side of the inverter to learn about the equipment status.

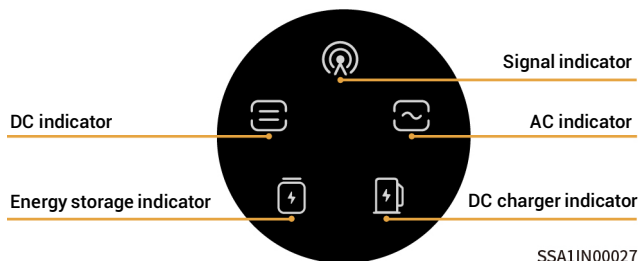

Indicator	Color	State	Description
		Always on	The DC side is connected but not running.
		Always on	The DC side is running.
		-	The DC side is not connected.
		Flash	The DC side is faulty.
		Always on	The inverter is faulty.
		Always on	The AC side is connected but not running.
		Always on	Grid-connected operation.
		Always on	Off-grid operation.
		-	The AC side is not connected.
		Flash	Off-grid overload operation.
		Flash	The AC side is faulty.
		Always on	The inverter is faulty.

Indicator	Color	State	Description
		Always on	All SigenStor BATs are connected but not running.
		Flash	SigenStor BAT is charging.
		Flash	SigenStor BAT is discharging.
		-	All SigenStor BATs lie dormant.
		Flash	Some SigenStor BATs are faulty.
		Always on	All SigenStor BATs are faulty.
		-	The management system is not connected.
		Flash	Connected to local App.
		Always on	Connected to the management system using an FE or WLAN.
		Always on	Connected to the management system over 4G.
		Flash	Insufficient traffic for Sigen CommMod.

After powering on the equipment, install the remaining decorative covers.

## Tips

If the installation fails even when you strictly follow the installation instructions, properly adjust the tightness of the chuck screw, as shown in the figure.

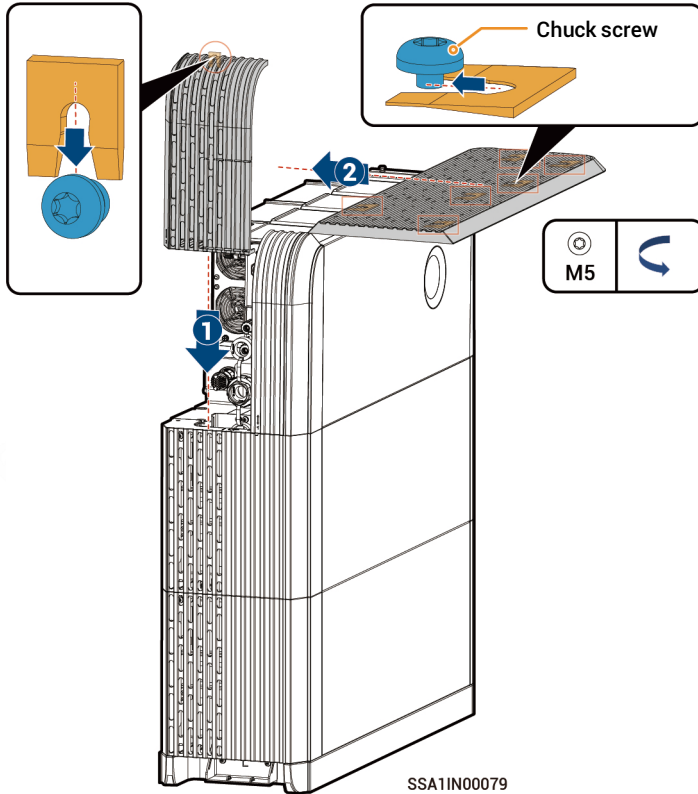

## 9 Download and create new system for mySigen APP

- 1 Please enter the "Partner" → "Register Now" at the Company's official website (<https://www.sigenergy.com>), and complete the account registration based on facts.
- 2 Download the mySigen App and create new system for the device.

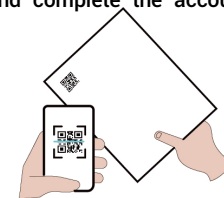
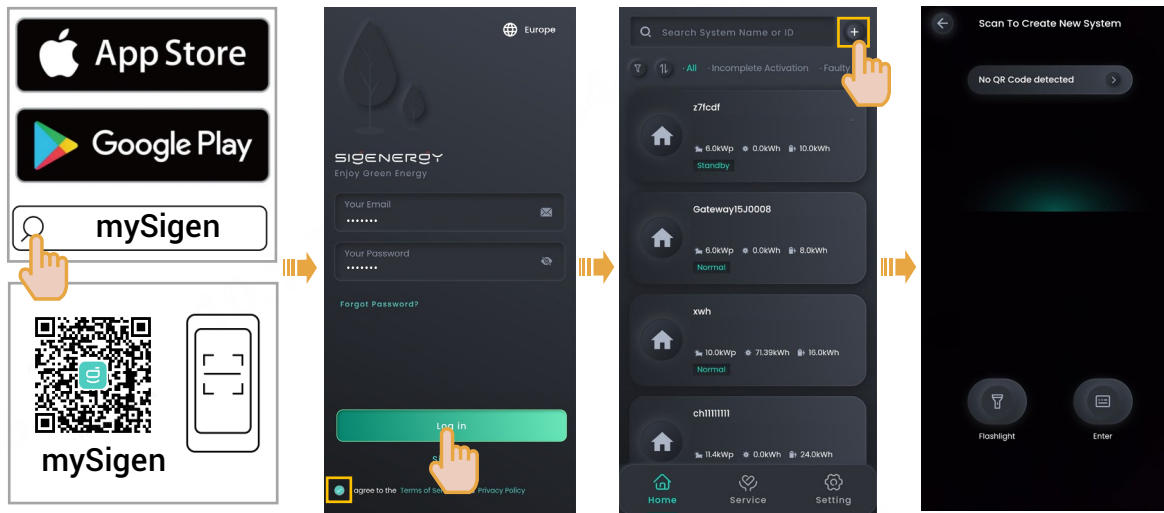

or

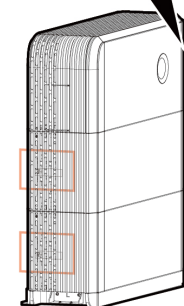

SSA11N00031

Scan the SN code label on the accompanying box material. If the SN is lost, scan the SN on the side of the inverter or SigenStor BAT.

### Tips

The following steps are different when the equipment has already been connected or not connected to the internet (that is, FE and 4G communication fault), as described below.

## Already connected to the internet:

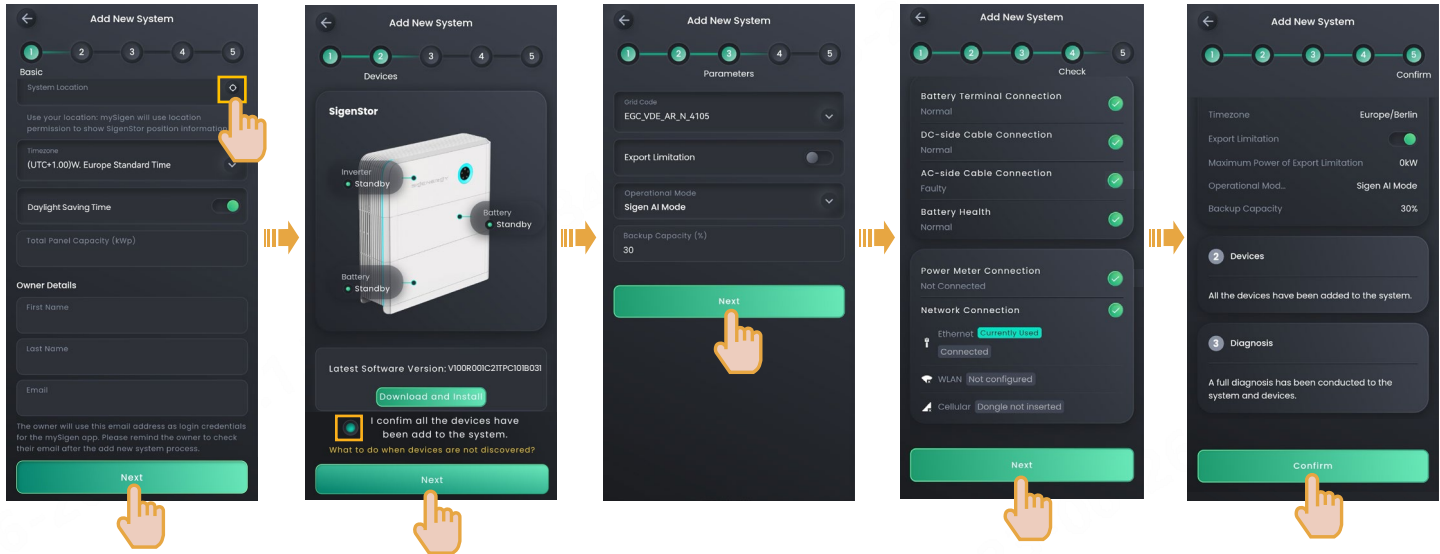

Manually locate the address, set the Timezone, and enter Owner Details.

Perform upgrades where necessary.

You can manually set and modify some function parameters of the power station.

**3** Upon completion of the new system creation, the installer shall inform the owner to check its "sigencloud" e-mail within 24 hours and proceed with activating its account.



# Not connected to the internet (that is, FE and 4G communication fault):

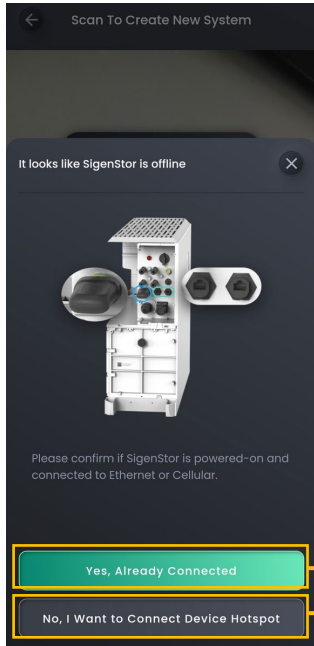

Click this button if the equipment is still not connected to the internet

**Caution**  
After create new system, the equipment hotspot is available for 2 hours. Please connect to the hotspot as soon as possible.

If the equipment has already been connected to the internet, click this button and go to the Create New System page and perform operations by referring to the description in the "already connected to the internet" section.

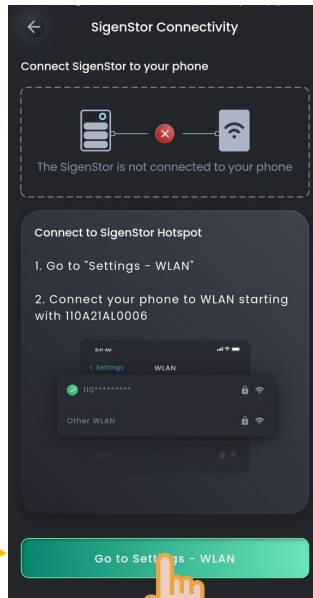

Connect the WLAN hotspot of the equipment. The hotspot is named equipment SN code.

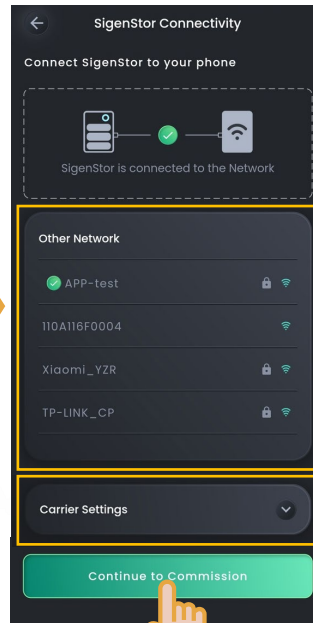

If connected to the WLAN hotspot at the owner's premises or if the SIM card APN is set (the device has a SIM card installed), click "Continue to Commission" to go to the page for creating new systems. You can refer to the description in the "already connected to the internet" section.

If there is no available WLAN hotspot at the owner's premises, or if the device has no SIM card installed, click "Continue to Commission" and follow the on-screen instructions to proceed.

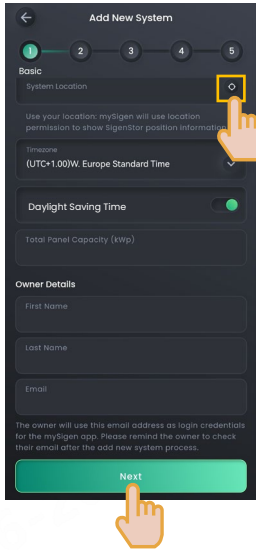

Manually locate the address, set the Timezone, and enter Owner Details.

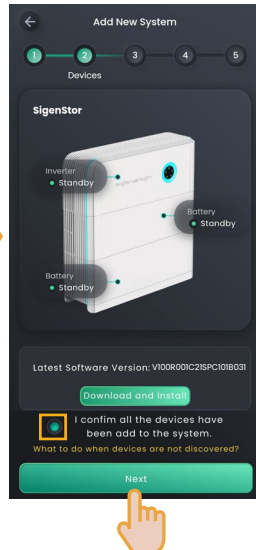

Perform upgrades where necessary.

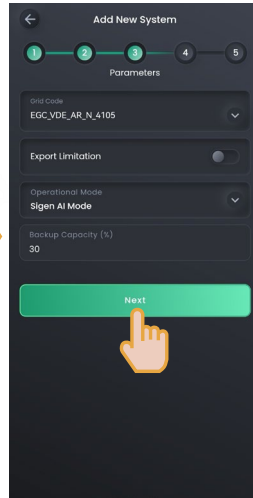

You can manually set and modify some function parameters of the power station.

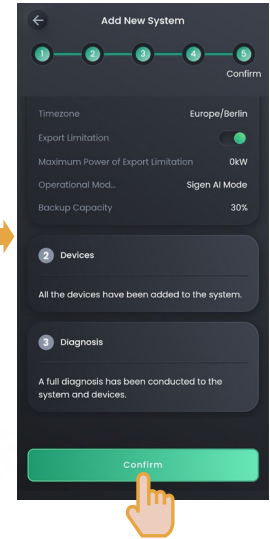
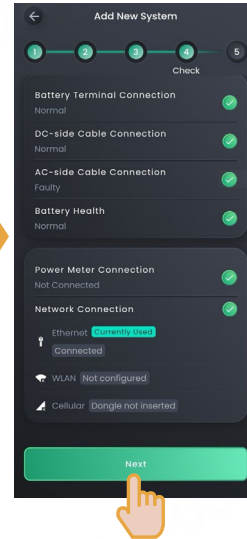

**3** Upon completion of the new system creation, the installer shall inform the owner to check its "sigencloud" e-mail within 24 hours and proceed with activating its account.

**Sigenergy Technology Co., Ltd.**



Website	LinkedIn	YouTube
---------	----------	---------

**[www.sigenergy.com](http://www.sigenergy.com)**



**Copyright © Sigenergy Technology Co., Ltd. 2024. All rights reserved.**

Description in this document may contain predictive statements regarding financial and operating results, product portfolio, new technology, configurations and features of product. Several factors could cause difference between actual results and those expressed or implied in the predictive statements. Therefore, description in this document is provided for reference purpose only and constitutes neither an offer nor an acceptance. Sigenergy Technology Co., Ltd. may change the information at any time without notice.