

INTRODUCTION OF ENERGY STORAGE INVERTERS

GOODWE SOLAR ACADEMY



**ACROSS THE OCEAN
TO STAY WITH YOU**

CONTENTS

1. ENERGY-STORAGE SOLUTIONS
2. OPERATION MODES
3. COMPARING ADVANTAGES
4. SYSTEM STUDY
5. OPERATION SCENARIOS

GOODWE SOLAR ACADEMY

ENERGY-STORAGE SOLUTIONS

GOODWE SOLAR ACADEMY



**ACROSS THE OCEAN
TO STAY WITH YOU**

WHAT WE HAVE

Single Phase Hybrid Inverter

New Hybrid Installation & On-Grid & Off-Grid
& UPS Loads & Battery Charged By PV And Grid

Low Voltage Battery (48V)

High Voltage Battery (85-450V)

100A

50A

25A



ES



EM



EH

INSTALL A NEW ENERGY STORAGE SYSTEM



	Model	GW3648D-ES	GW5048D-ES
Battery	Supported Battery	Li-Ion (48V)	
	Max Charge Current	75A	100A
	Max Discharge Current	75A	100A
DC Input	Max DC Input Power	4600 W	6500 W
	No. of MPPT Tracker	2	2
Back-Up	Max Apparent Power	3680 VA	4600 VA
	Peak Output Power	5520VA, 10s	6900VA, 10s

	Model	GW3048-EM	GW3648-EM	GW5048-EM
Battery	Supported Battery	Li-Ion (48V)		
	Max Charge Current	50A	50A	50A
	Max Discharge Current	50A	50A	50A
DC Input	Max DC Input Power	3900	4600	6500
	No. of MPPT Tracker	1	2	2
Back-Up	Max Apparent Power	2300 VA	2300 VA	2300 VA
	Peak Output Power	3500VA, 10s	3500VA, 10s	3500VA, 10s

	Model	GW3600-EH	GW5000-EH	GW6000-EH
Battery	Supported Battery	Li-Ion (85-450V)		
	Max Charge Current	25A	25A	25A
	Max Discharge Current	25A	25A	25A
DC Input	Max DC Input Power	4320	6000	7200
	No. of MPPT Tracker	2	2	2
Back-Up	Max Apparent Power	3600 VA	5000 VA	6000 VA
	Peak Output Power	4320 VA, 10s	6000 VA, 10s	7200 VA, 10s

WHAT WE HAVE

Single Phase Retrofit Storage Inverter

On Grid System Retrofit Installation

DC Coupled

AC Coupled

Low Voltage Battery

Low Voltage Battery

High Voltage Battery



BP



SBP



BH
1KW-3KW

RETROFIT EXISTED GRID-TIED SYSTEM



	Model	GW2500-BP
Battery	Supported Battery	Li-Ion (48V)
	Max Charge Current	50
	Max Discharge Current	50
PV Input	Max PV Input Power	6000 W
	Max PV Input Voltage	500V
	Max PV Input Current	25A
	No. PV Strings	1

	Model	GW3600 S-BP	GW5000 S-BP
Battery	Supported Battery	Li-Ion (48V)	
	Max Charge Current	75A	100A
	Max Discharge Current	75A	100A
Back-Up	Max Apparent Power	3680W	5000W
	Peak Output Power	4416VA, 10s	5500VA, 10s
	Max Output Current	16A	22.8A

	Model	GW1000-BH	GW2000-BH	GW3000-BH
Battery	Supported Battery	Li-Ion (80-400V)		
	Max Charge Current	13A	15A	15A
	Max Discharge Current	13A	15A	15A
AC Output	Norminal Power Output to Grid	1000W	2000W	3000W
	Norminal Current Output to Grid	5A	10A	13.5A
	Norminal Output Voltage	230V	230V	230V

WHAT WE HAVE

Three Phase Hybrid Inverter

New Hybrid Installation & On-Grid & Off-Grid
& UPS Loads & Battery Charged by PV and Grid

High Voltage Battery (180-600V)

25A



ET

INSTALL A NEW ENERGY STORAGE SYSTEM



	Model	GW5K-ET	GW8K-ET	GW10K-ET	
Battery	Supported Battery Type	Li-Ion	Li-Ion	Li-Ion	
	Nominal Battery Voltage (V)	180-600	180-600	180-600	More Option
	Max Charge/Discharge Current (A)	25	25	25	Less Heat, Longer Life
	Charge Pattern (Li-Ion Battery)	Self-adaption To BMS			Higher Accuracy
DC Input Specifications	Max DC Input Power (W)	6500	9600	13000	30% Over-sizing
	Max DC Input Voltage (V)	1000	1000	1000	
	MPPT Voltage Range (V)	200~850	200~850	200~850	
	Start-up Voltage (V)	180	180	180	Work Longer Per Day
	MPPT Range For Full Load (V)	240~850	380~850	460~850	
	Max Input Current (A)	12.5/12.5	12.5/12.5	12.5/12.5	
	No. Of MPPT Tracker	2	2	2	
	No. Of Input Strings Per MPPT	1/1	1/1	1/1	

INSTALL A NEW ENERGY STORAGE SYSTEM



Back-Up Specifications	Max Apparent Power (VA)	5000	8000	10000	
	Peak Output Apparent Power (VA)	10000, 60s	16500, 60s	16500, 60s	Overload ability
	Max Output Current (A)	8.5	13.5	16.5	
	Nominal Output Voltage (V)	400/380	400/380	400/380	
	Nominal Output Frequency (Hz)	50/60	50/60	50/60	
	Automatic Switch Time (ms)	< 10	< 10	< 10	UPS Supply
	Output THDv (liner load)	< 3%	< 3%	< 3%	
On-Grid Specifications	Nominal Power Output to Grid (W)	5000	8000	11000	
	Max Apparent Power From Grid (VA)	10000	15000	15000	Back-Up & Battery together
	Nominal Output Voltage (V)	400/380 3L/N/PE			
	Nominal Output Frequency (Hz)	50/60	50/60	50/60	
	Max AC Output Current to Grid (A)	8.5	13.5	16.5	
	Max AC Current from Grid (A)	15.2	22.7	22.7	Back-Up & Battery together
	Power Factor	0.8 leading~0.8 lagging			PF value adjustable
	Output THDi (@Nominal output)	< 3%	< 3%	< 3%	

WHAT WE HAVE

Three Phase Retrofit Inverter

On-Grid System AC Coupled Retrofit Installation

High Voltage Battery (180-600V)

25A



BT (5-10KW)

RETROFIT EXISTED GRID-TIED SYSTEM

Technical Data	GW5K-BT	GW6K-BT	GW8K-BT	GW10K-BT
Battery Input Data				
Battery Type	Li-Ion	Li-Ion	Li-Ion	Li-Ion
Battery Voltage Range (V)	180~600			
Max. Charge/Discharge Current (A)	25	25	25	25
Charging Strategy for Li-Ion Battery	Self-adaption to BMS			
AC Output Data (On-grid)				
Nominal Apparent Power Output to Utility Grid (VA)	5000	6000	8000	10000
Max. Apparent Power Output to Utility Grid (VA) *	5500	6600	8800	11000
Max. Apparent Power from Utility Grid (VA)	10000	12000	15000	15000
Nominal Output Voltage (V)/ Frequency	400/380, 3L/N/PE, 50/60Hz			
Max. AC Current Output to Utility Grid (A)	8.5	10.5	13.5	16.5
Max. AC Current From Utility Grid (A)	15.2	18.2	22.7	22.7
Output Power Factor	~1 (Adjustable from 0.8 leading to 0.8 lagging)			
Output THDi (@Nominal Output)	<3%			
AC Output Data (Back-up)				
Max. Output Apparent Power (VA)	5000	6000	8000	10000
Peak Output Apparent Power (VA) **	10000, 60sec	12000, 60sec	15000, 60sec	15000, 60sec
Max. Output Current (A)	8.5	10.5	13.5	16.5
Nominal Output Voltage / Frequency	400/380V, 50/60Hz			
Output THDv (@Linear Load)	<3%			

WHAT WE HAVE

Upcoming Products



BH (3.6-6KW)



EMJP



All-In-One



BT 50KW

OPERATION MODES

GOODWE SOLAR ACADEMY



**ACROSS THE OCEAN
TO STAY WITH YOU**

ES & EM & EH & ET Operation Modes



In the daytime



PV

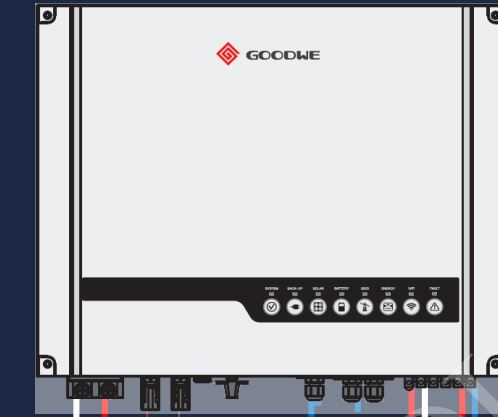

2



Low/High Voltage Li-Ion Battery

1



Back-Up Loads

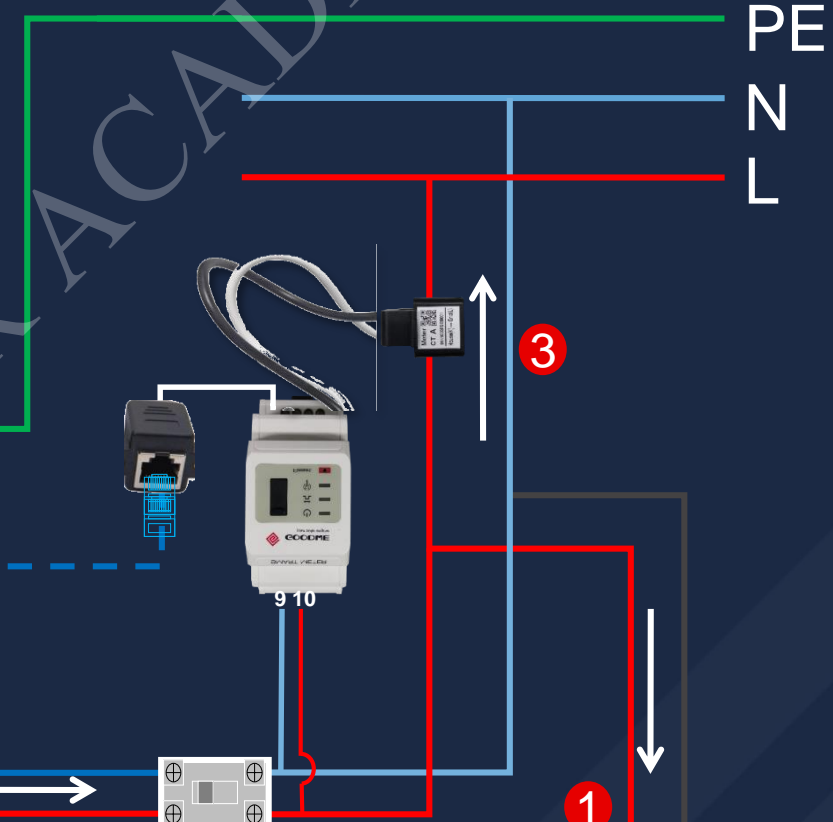

1



On-Grid Loads

PE
N
L

3

ES & EM & EH & ET Operation Modes

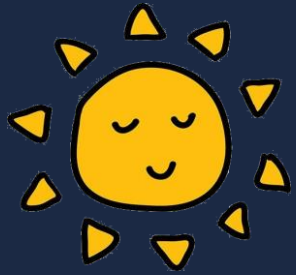

At Sunset

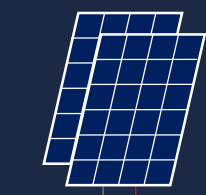

PV

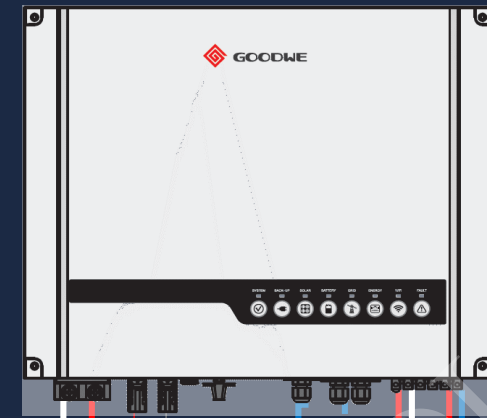

Low/High Voltage Li-Ion Battery



Back-Up Loads

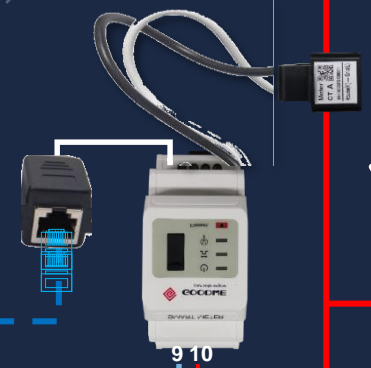

9 10



On-Grid Loads

PE
N
L

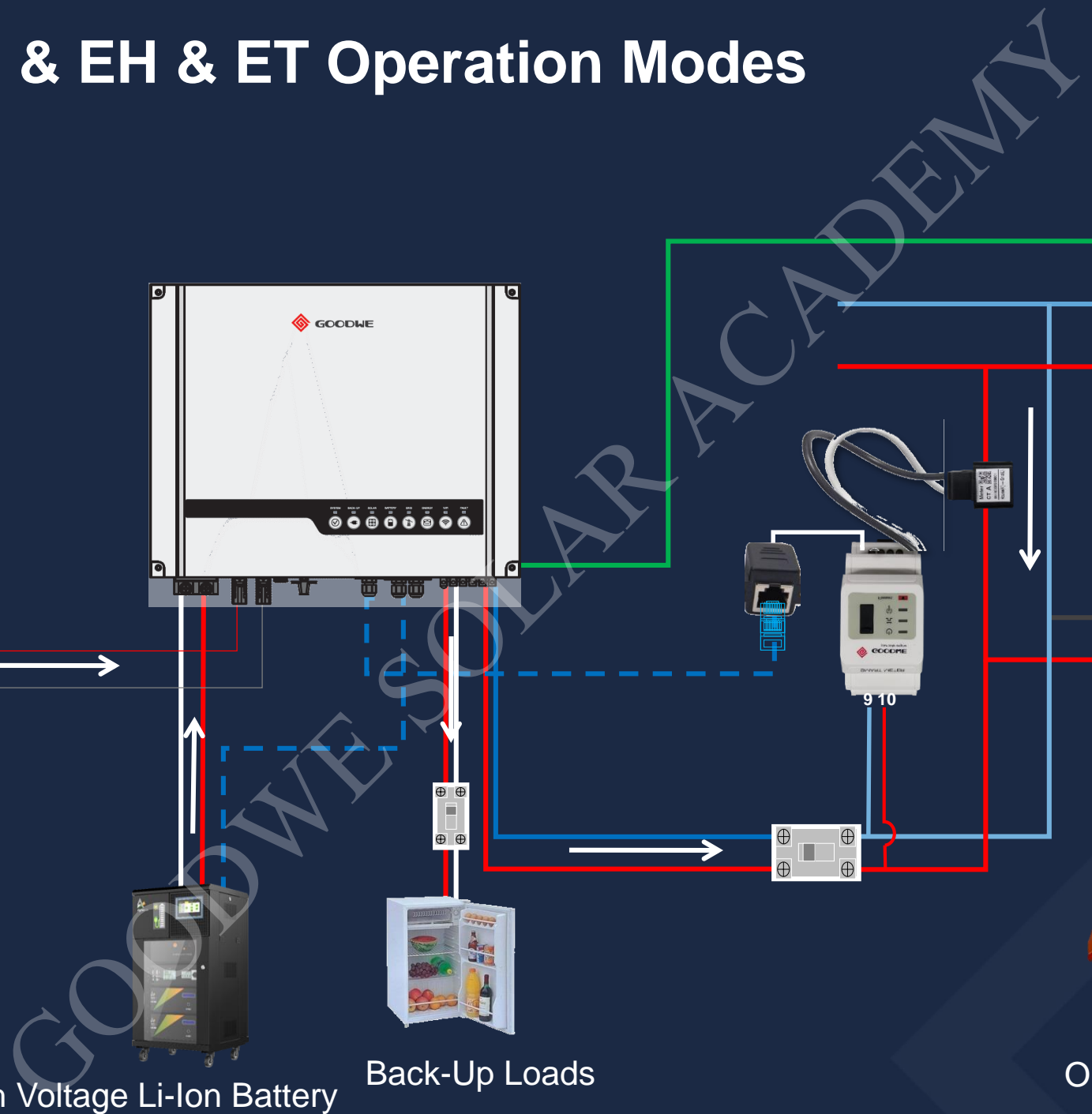

ES & EM & EH & ET Operation Modes



At Night

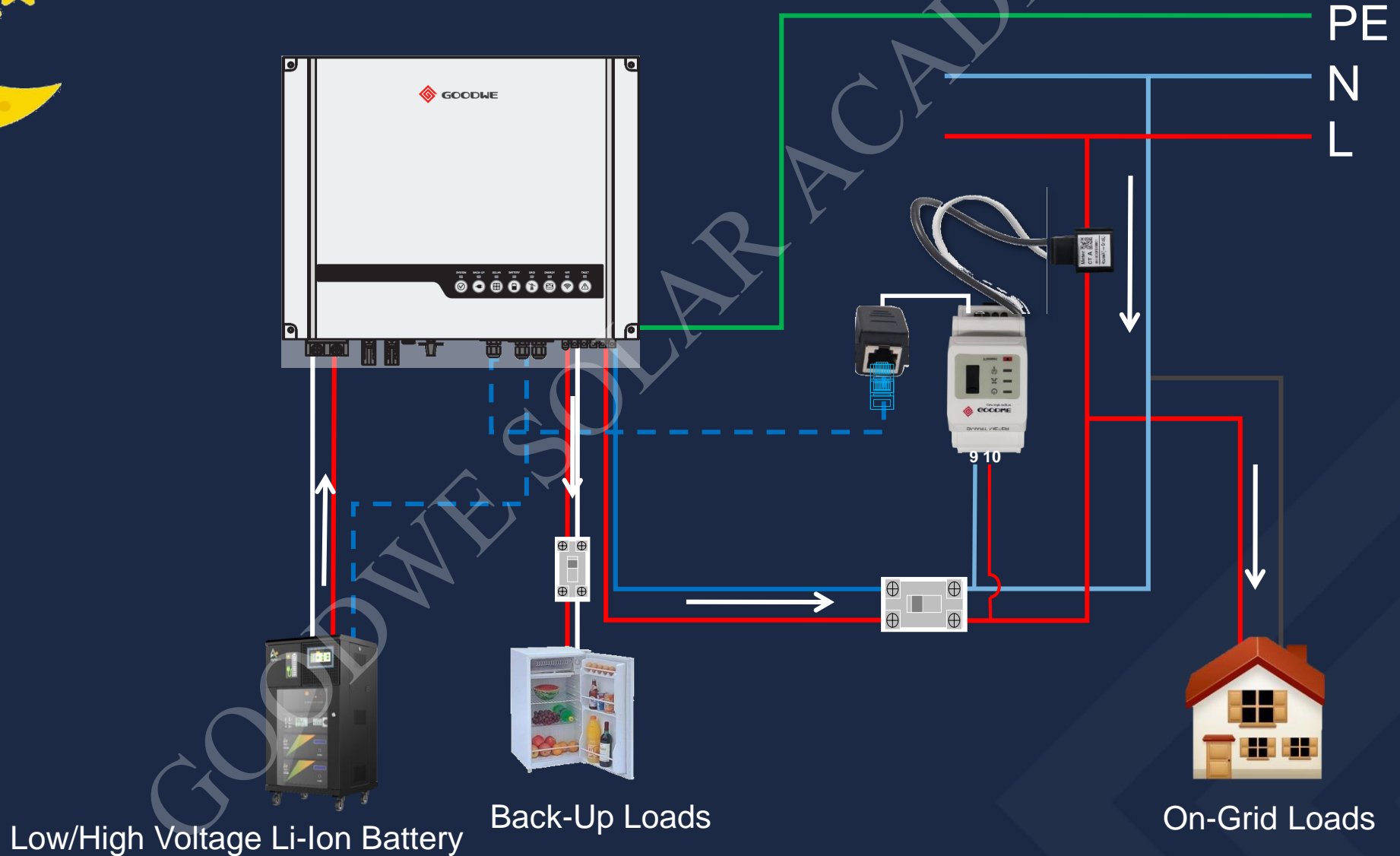

ES & EM & EH & ET Operation Modes



At Early Morning

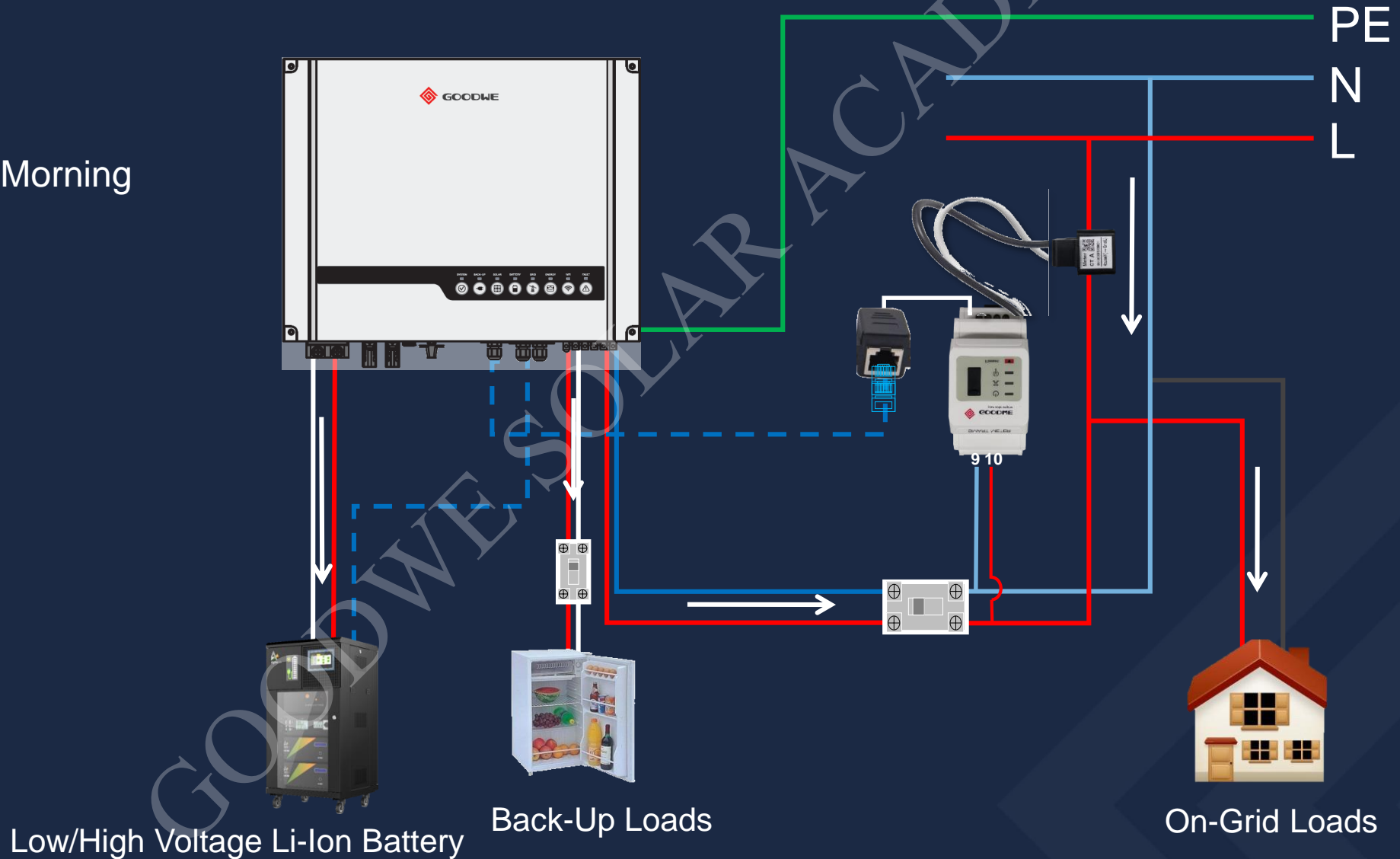

ES & EM & EH & ET Operation Modes



Grid Fails



PV

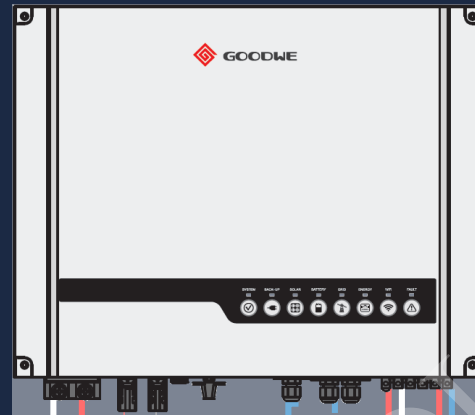

Low/High Voltage Li-Ion Battery



Back-Up Loads

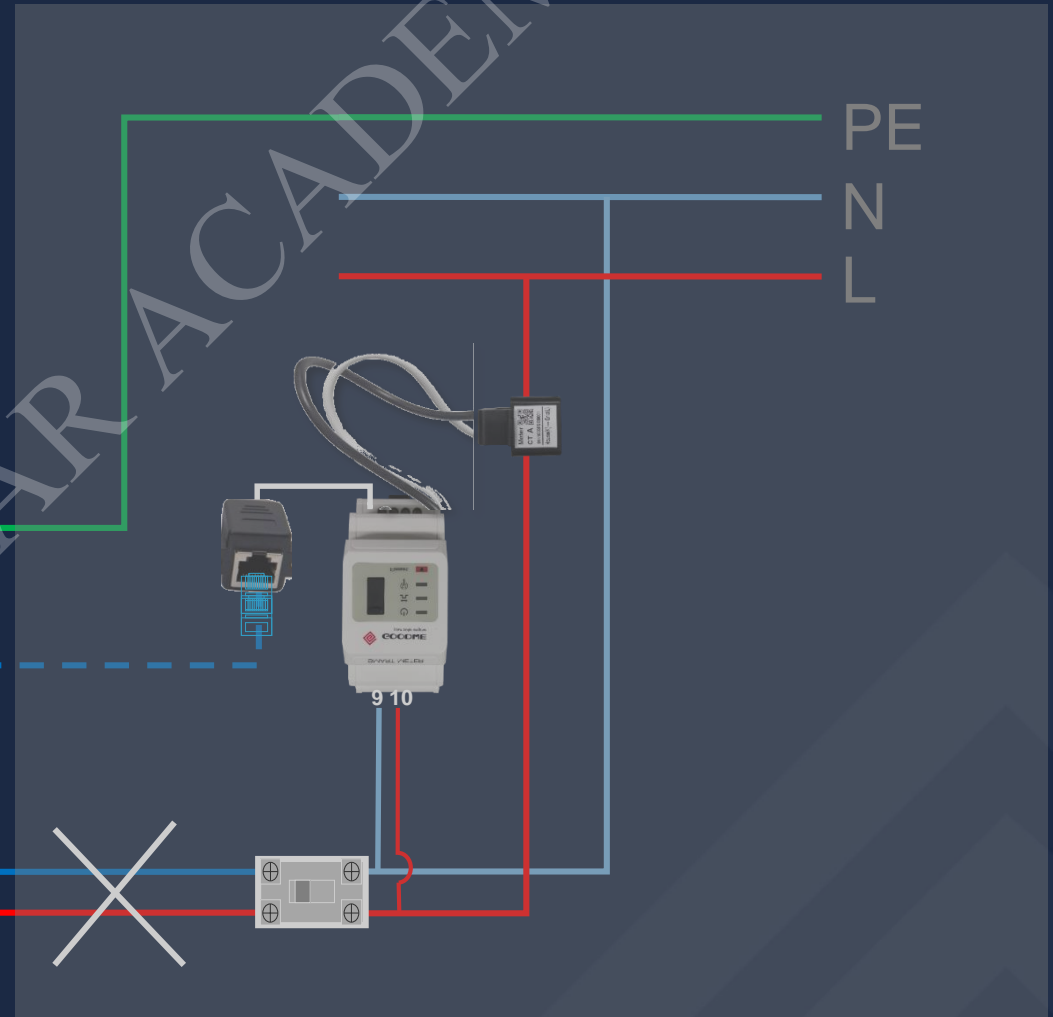

ES & EM & EH & ET Operation Modes

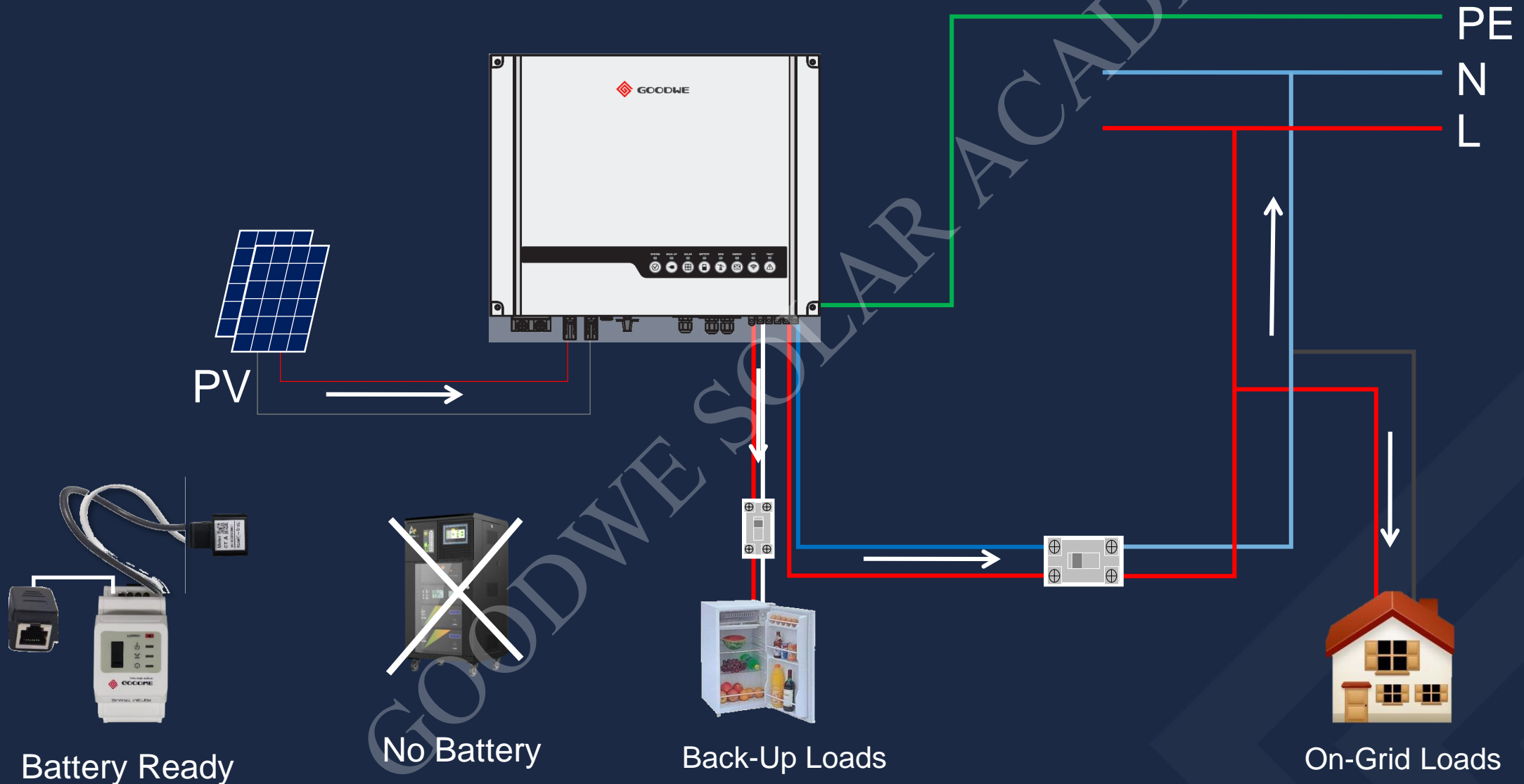

BP Operation Modes

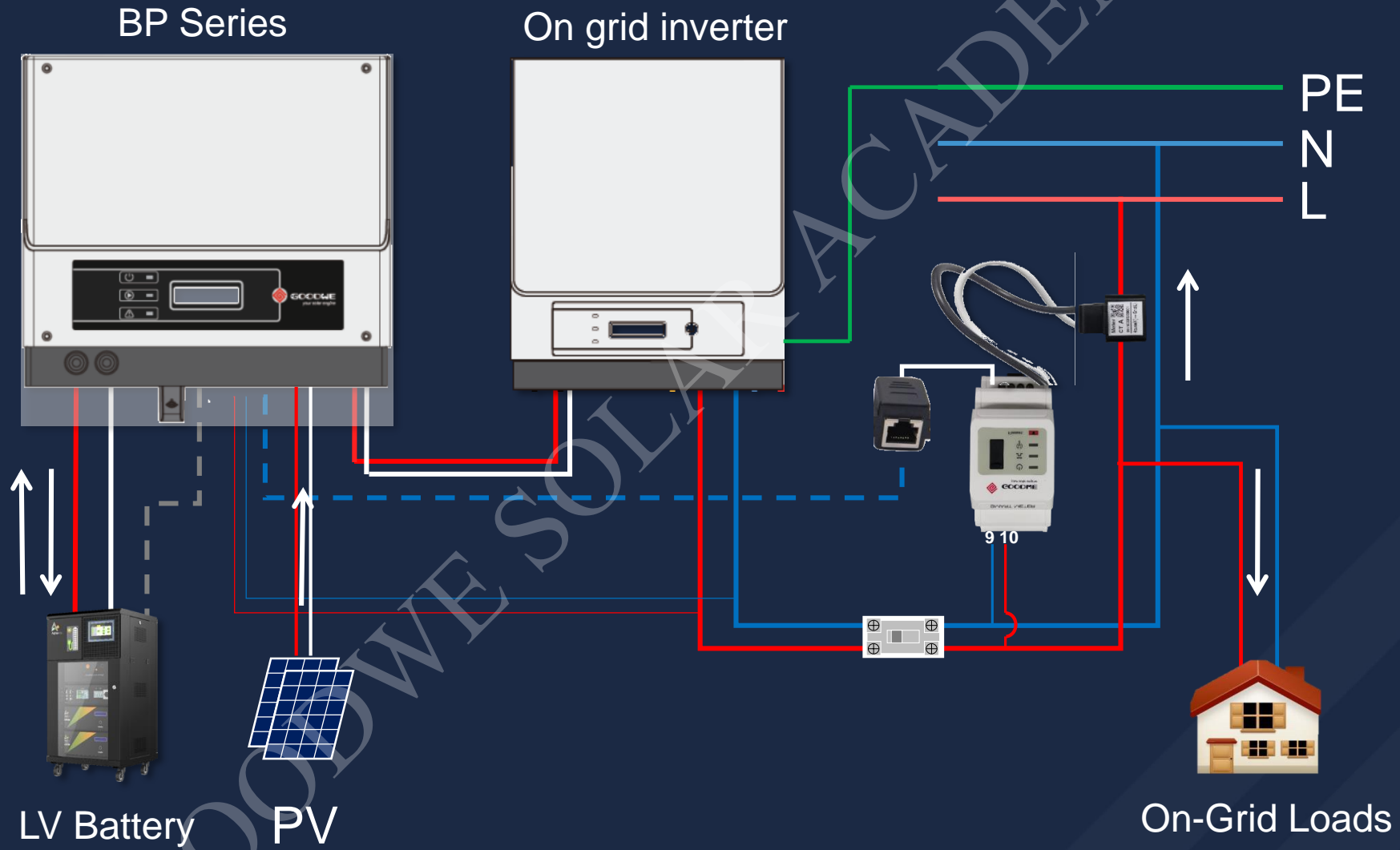

S-BP & BT Operation Modes

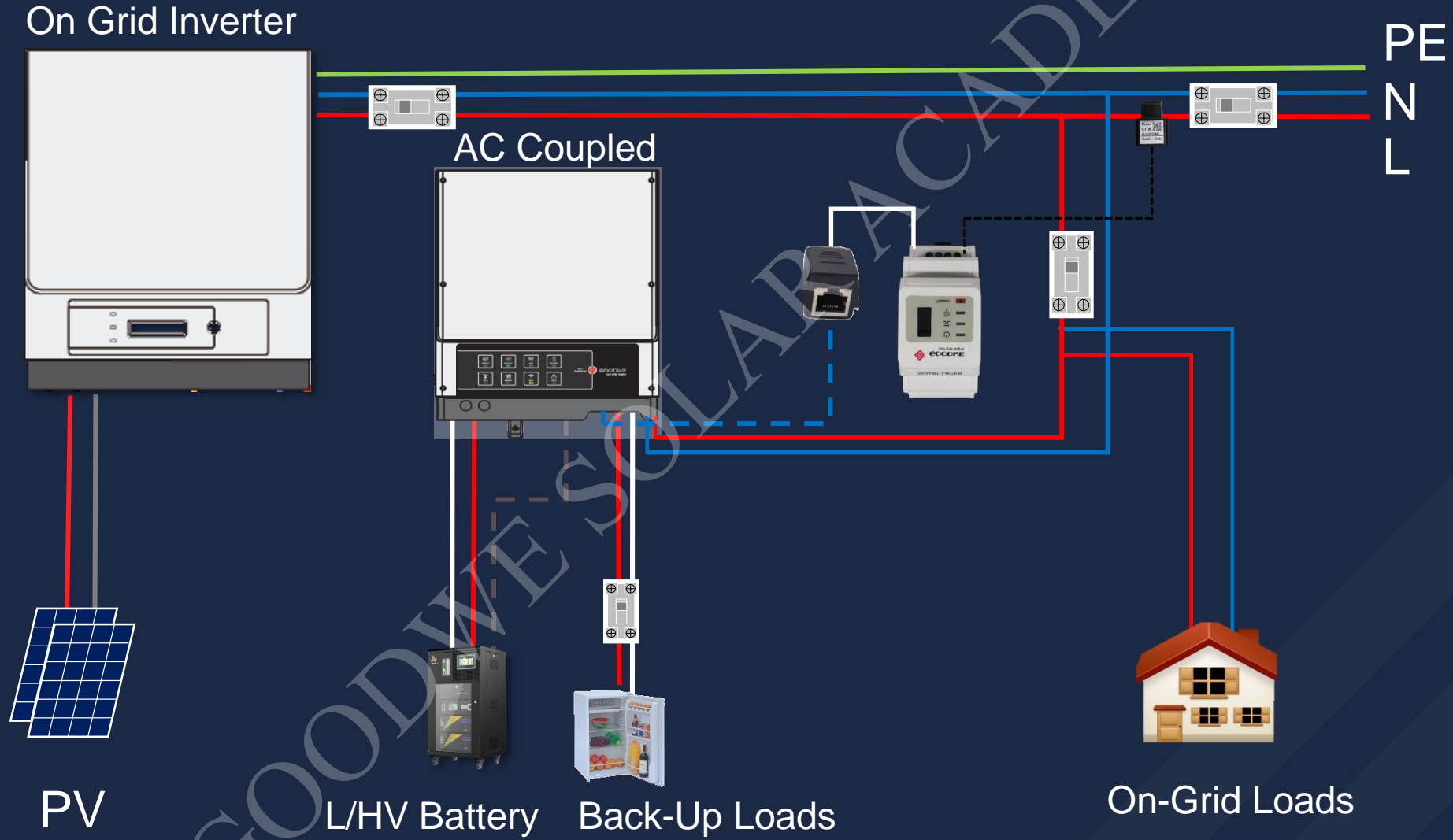

BH Operation Modes

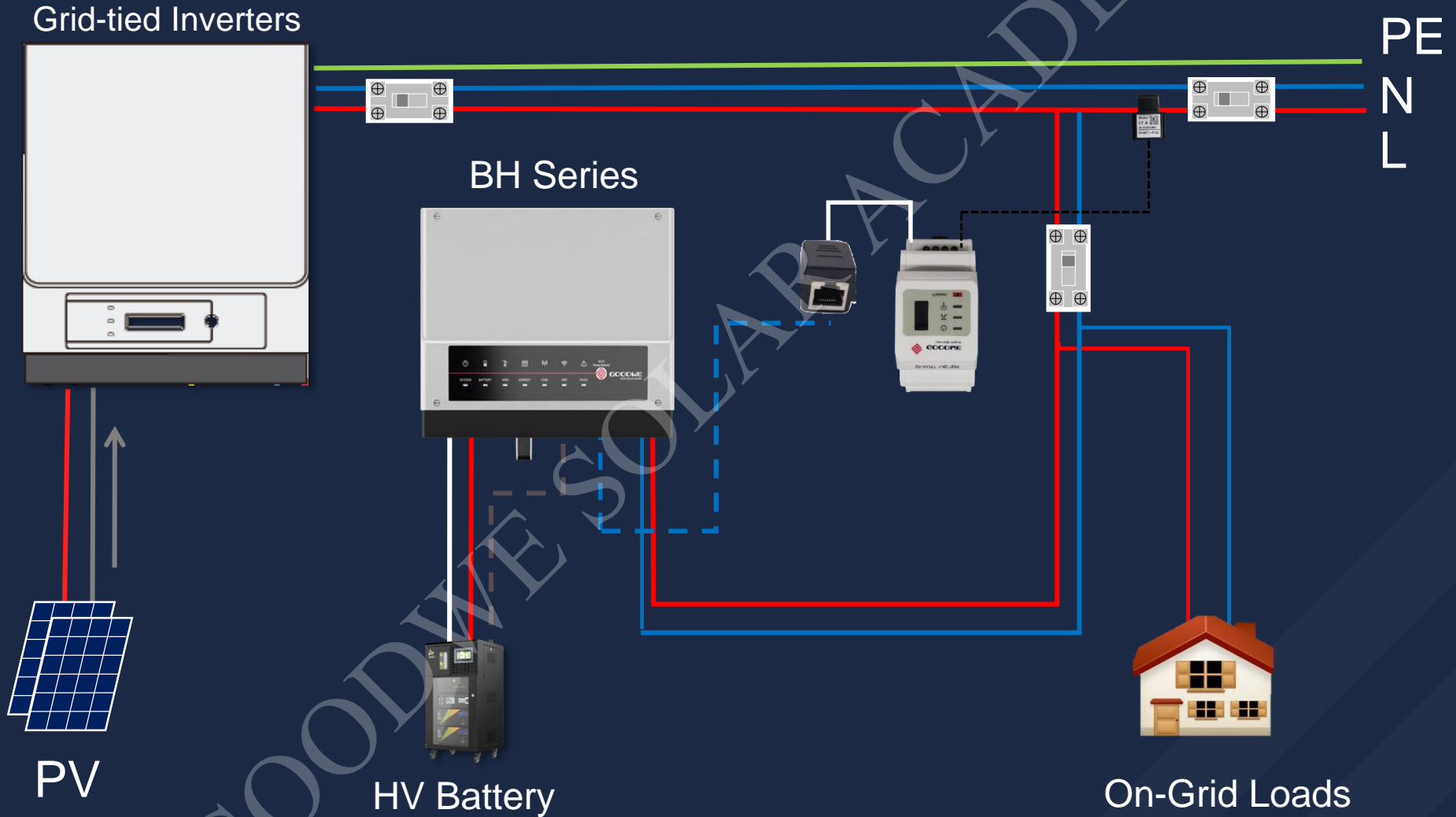



GOODWE
SOLAR ACADEMY

ADVANTAGES

- INSTALLATIONS
- SPECIFICATIONS

GOODWE SOLAR ACADEMY



**ACROSS THE OCEAN
TO STAY WITH YOU**

FRIENDLY INSTALLATIONS

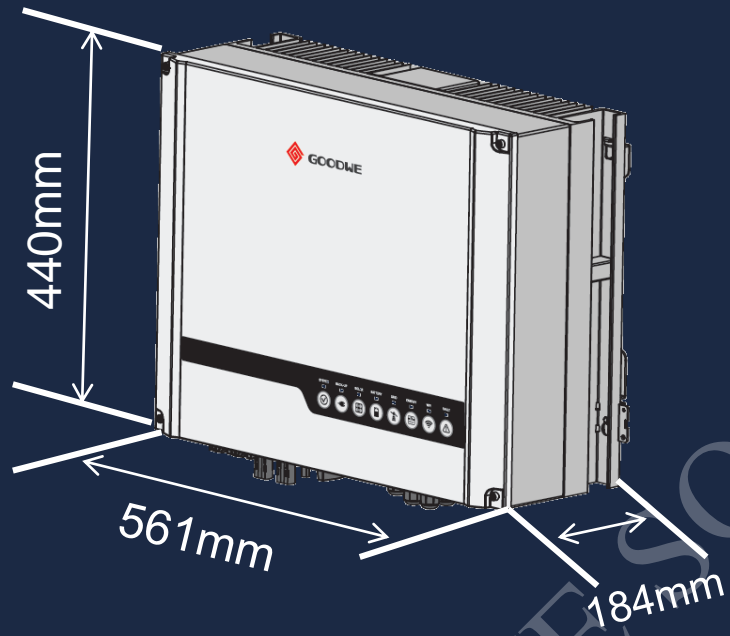

Weight: 30kg

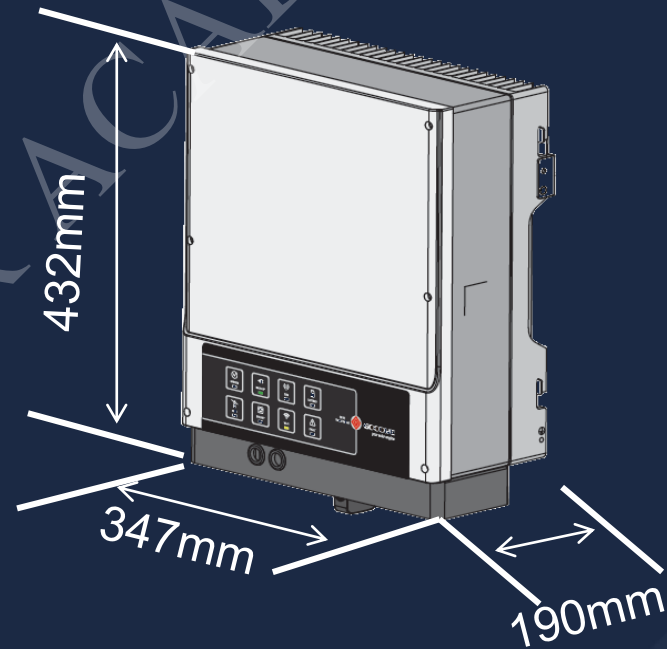

Weight: 18.5kg

High Power Density

Handle for One Adult

FRIENDLY INSTALLATIONS

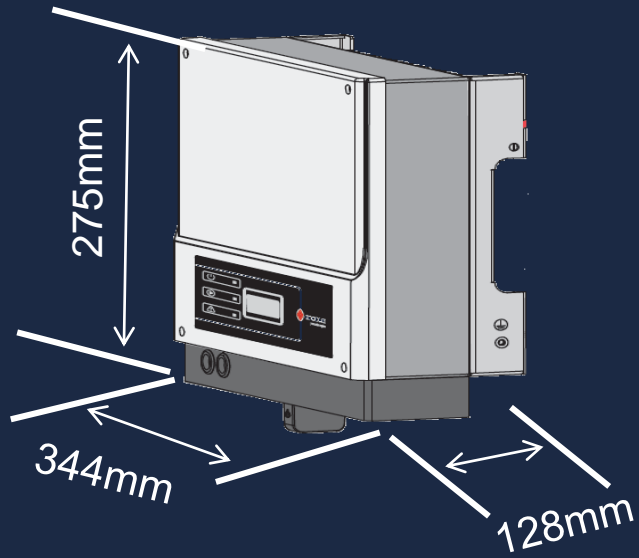

Weight: 8kg



Weight: 18.5kg



Weight: 23-25kg

High Power Density

Handle for One Adult

FRIENDLY INSTALLATIONS

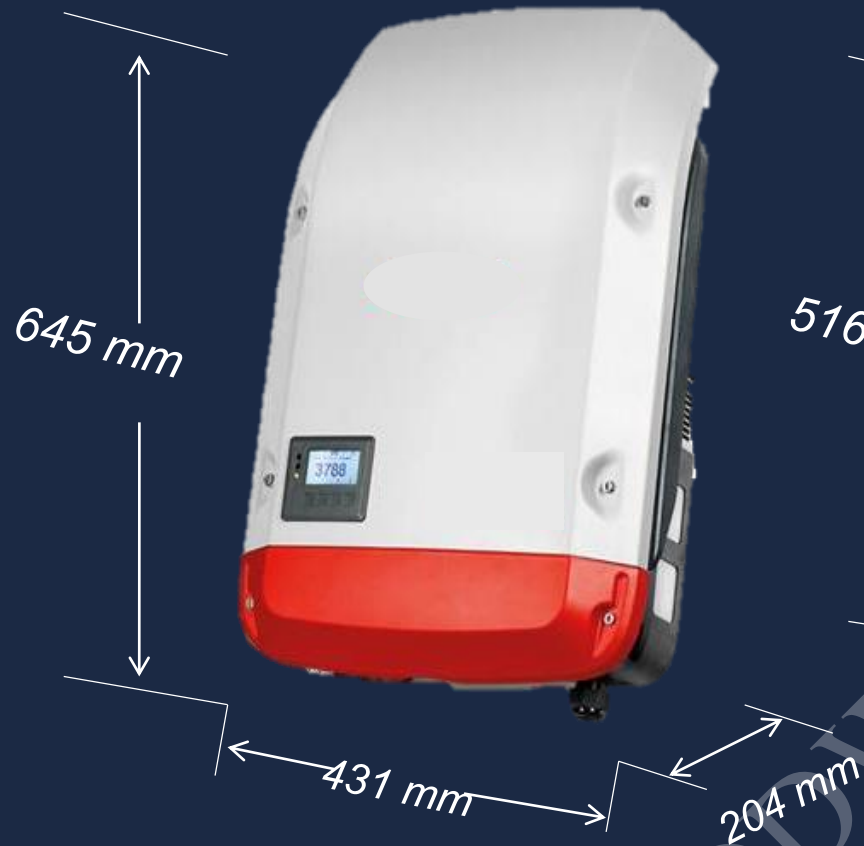

3KW-5KW
Weight: 19.9kg







































5KW-10KW
Weight: 23-25kg



5KW-10KW
Weight: 40kg

FRIENDLY INSTALLATIONS

Cables & Meter & CT Ready

INDICATOR	STATUS	EXPLANATIONS
 SYSTEM		ON=SYSTEM IS READY
		BLINK=SYSTEM STARTING UP
		OFF= SYSTEM NOT OPERATING
 BACK-UP		ON= BACK-UP POWER IS AVAILABLE
		OFF= NO OUTPUT ON BACK-UP
 COM		ON=BMS & METER COM IS OK
		BLINK 1=METER COM IS OK BMS COM FAILS
		BLINK 2=BMS COM IS OK EZMEER COM FAILS
		OFF=BMS & EZMETER COM FAIL
 BATTERY		ON=BATTERY IS CHARGING
		BLINK1 = BATTERY DISCHARGING
		BLINK2 = BATTERY SOC IS LOW
		OFF = BATTERY IS DISCONNECTED
 GRID		ON = GRID IS ACTIVE & CONNECTED
		BLINK = GRID IS ACTIVE BUT NOT CONNECTED
		OFF = GRID IS NOT ACTIVE
 ENERGY		ON = BUYING POWER FROM GRID
		BLINK1 = ZERO EXPORTING TO GRID
		BLINK2 = SELLING POWER TO GRID
		OFF = GRID NOT CONNECTED
 Wi-Fi		ON = WIFI CONNECTED
		BLINK1 = WIFI RESTARTING
		BLINK2 = WIFI NOT CONNECTED TO ROUTER
		BLIBK4 = SERVER PROBLEM
		OFF = WIFI NOT ACTIVE
 FAULT		ON = AN ERROR OCCURSS
		BLINK = BACK-UP OVERLOAD
		OFF = NO ERROR

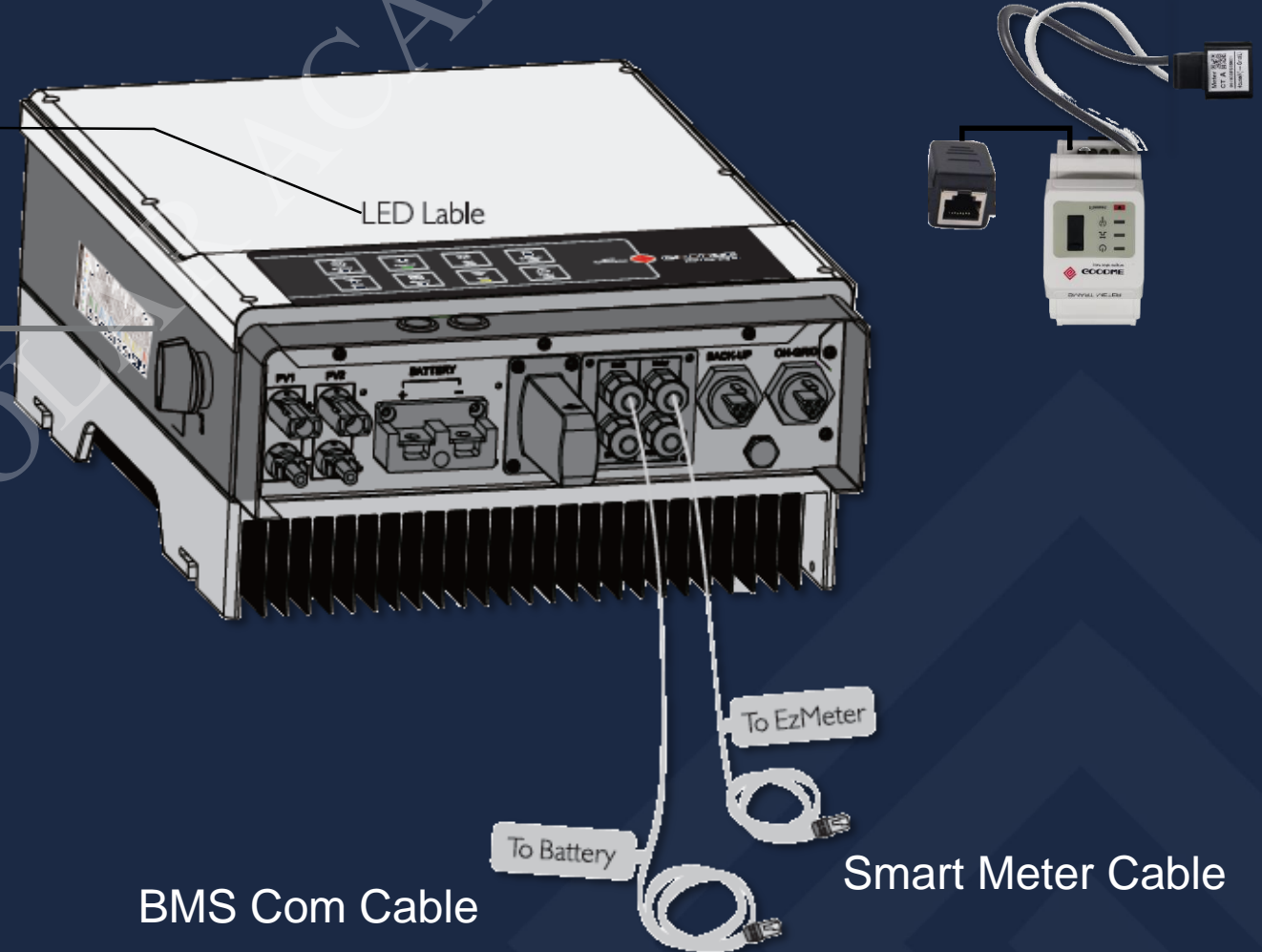

BMS Com Cable

Smart Meter Cable

FRIENDLY INSTALLATIONS

WIFI RESET

LED LABEL

DC SWITCH

VENT VALVE

PV CONNECTOR

BATTERY CONNECTOR

WIFI MODULE

LEDS

SOC INDICATOR

ON-GRID PORT
BACK-UP PORT

SMART METER COM

BMS COM
DRED

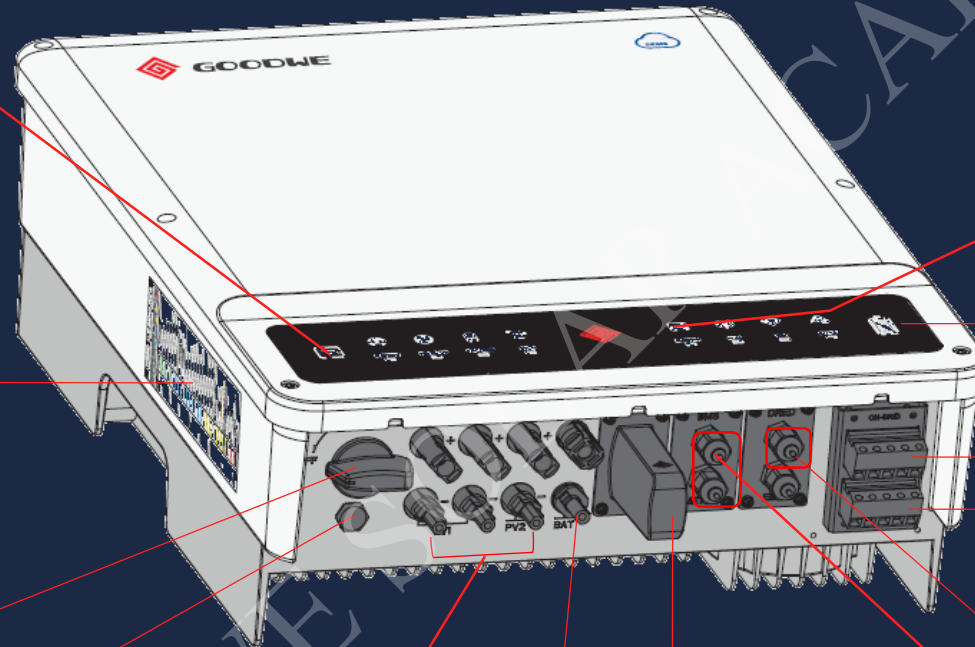

FRIENDLY INSTALLATIONS

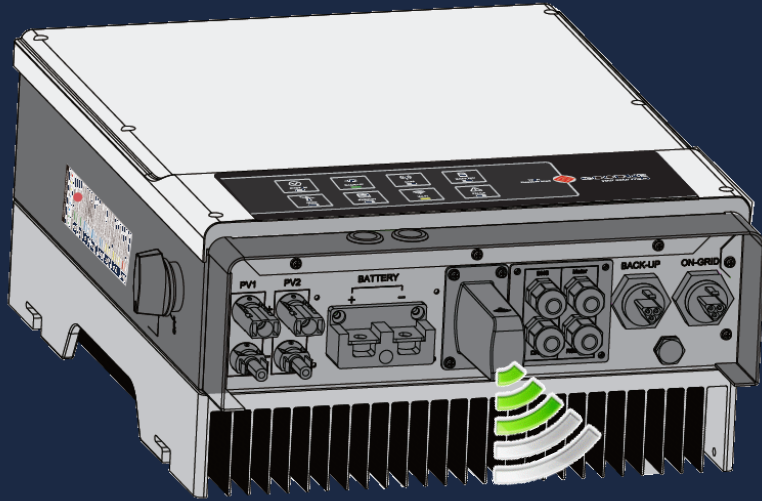

Convenient configurations

Quick WiFi Configuration

- All on App
- 4 click will finish all

Quick Parameter Setting

- All on App --
- 3 options set system ready --



GoodWe App

FRIENDLY INSTALLATIONS

WiFi / Lan Communication



WIFI CONFIGURATION

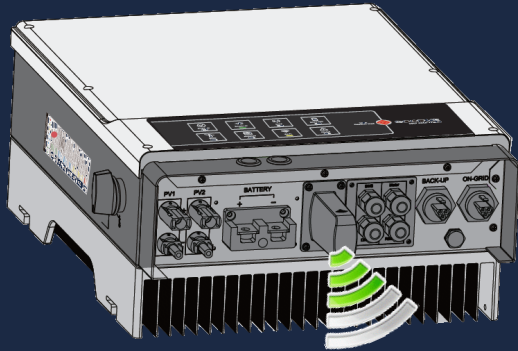

Choose network and fill in its password

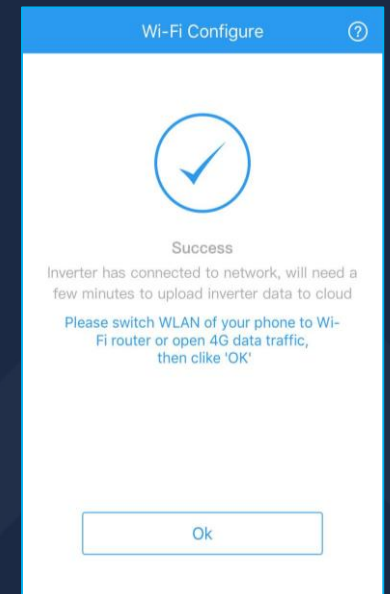
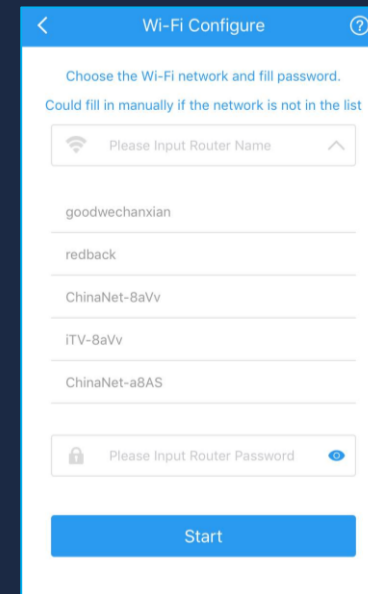
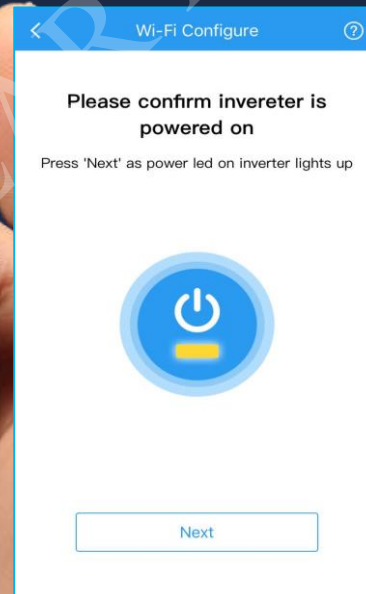
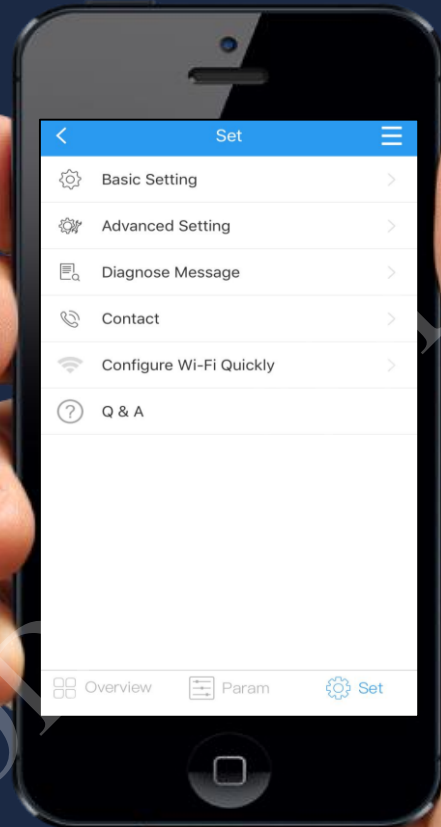

FRIENDLY INSTALLATIONS



Basic Setting

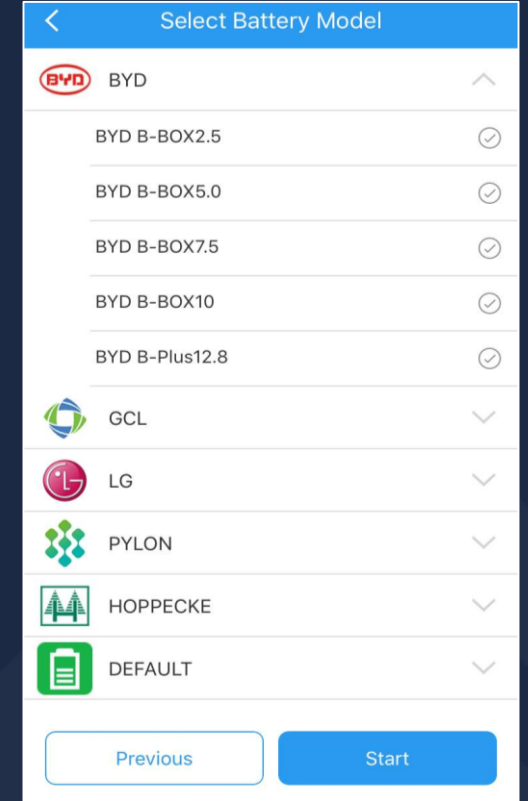
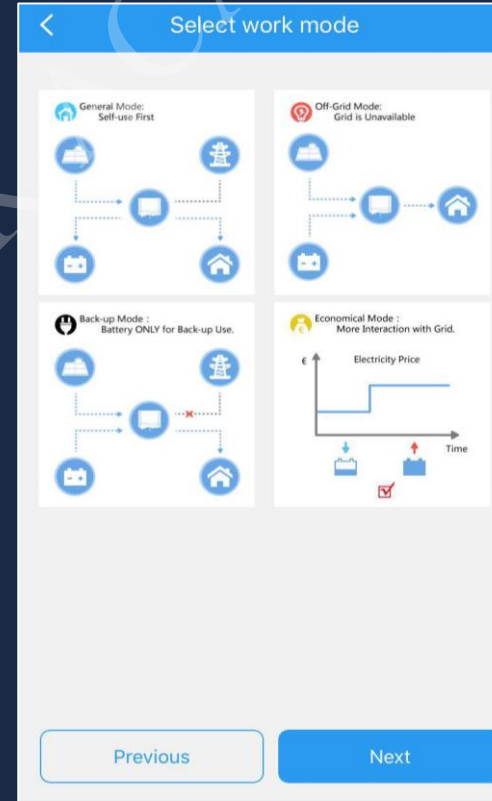
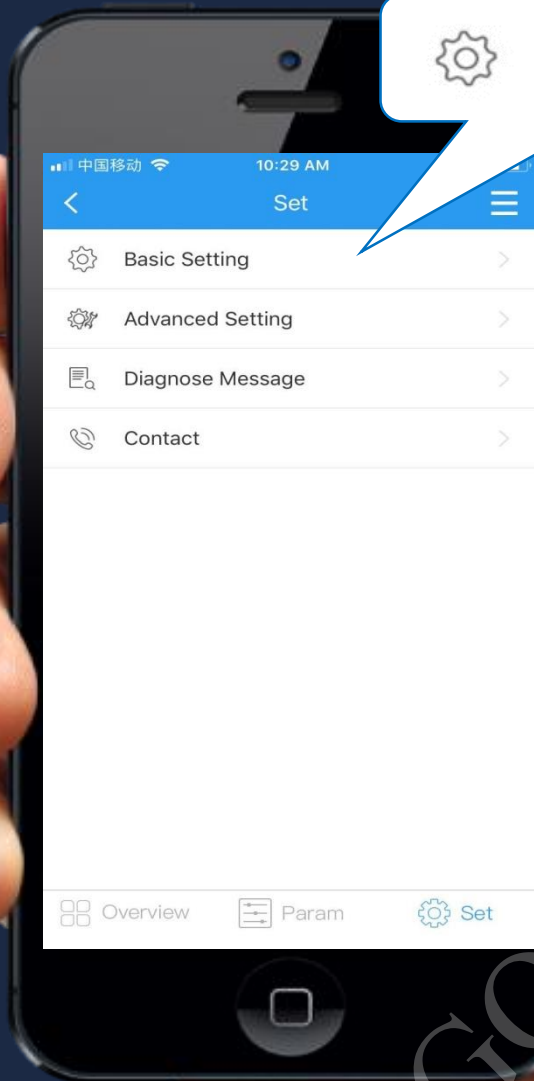

PRODUCT ADVANTAGES

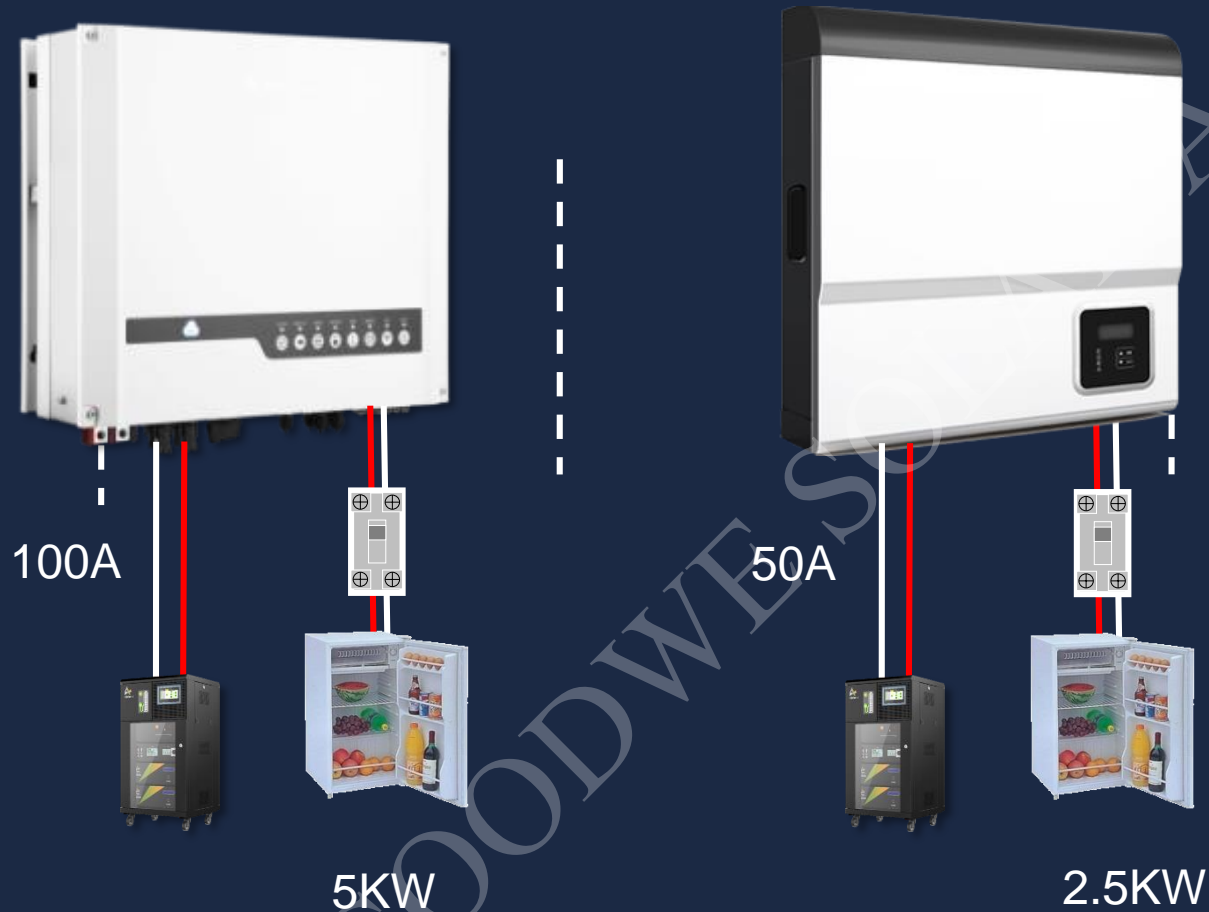

Double ability for backup loads

- Max 100A charge/discharge current
- Max Support 5KW Backup Loads

PRODUCT ADVANTAGES

Low Voltage Battery Compatible Brands

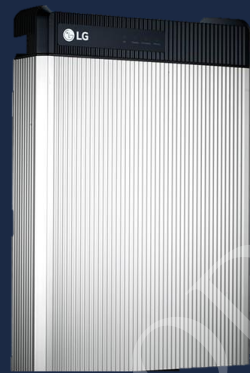

PRODUCT ADVANTAGES

High Voltage battery compatible brands



PRODUCT ADVANTAGES

Won the "All Quality Matters Award" in the 2016&2017&2018



PRODUCT ADVANTAGES

UPS
< 10ms

Switch between on-grid and off-grid mode

PRODUCT ADVANTAGES

UPS VS EPS

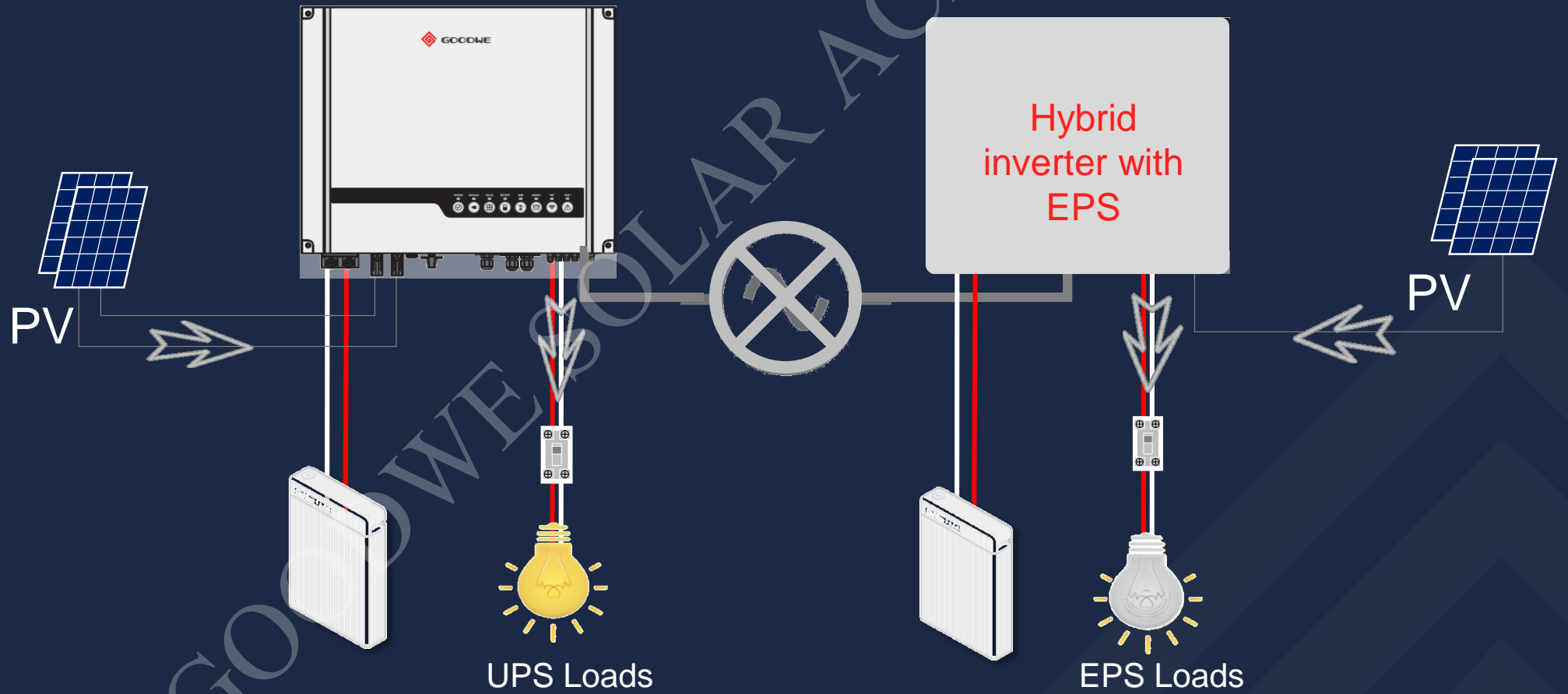

PRODUCT ADVANTAGES

GW10K-ET



Back-Up side supports unbalanced power supply on each phase

1.3KW

0.5KW

1.0W



Back-Up



3-phase loads 6KW

GOODWE SOLAR ACADEMY

PRODUCT ADVANTAGES



IP65

Protection from high humidity and dust

GOODWILL SOLAR ACADEMY

PRODUCT ADVANTAGES



REMOTE CONTROL

Configuration

Parameters Modification

Firmware Update

SEMS Reserved

GOODWIE SOLAR ACADEMY

PRODUCT ADVANTAGES

GOOD WE SOLAR ACADEMY



✓ 25dB

SYSTEM STUDY

GOODWE SOLAR ACADEMY



**ACROSS THE OCEAN
TO STAY WITH YOU**

SBP Compatible With Three-Phase Grid

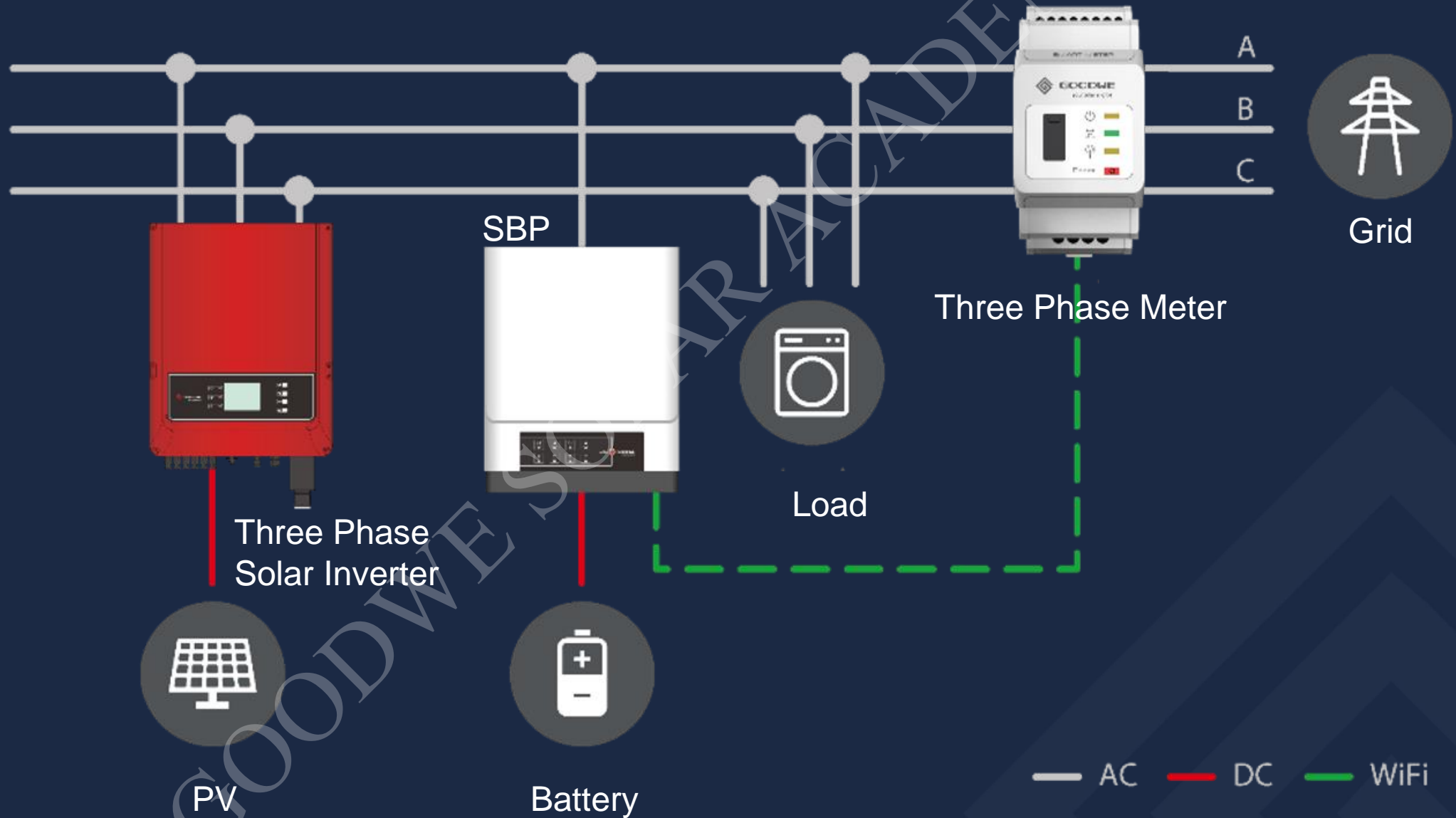

Battery Ready – DSS Series



PV



DC Coupled



AC Coupled



Battery Ready – XS Series

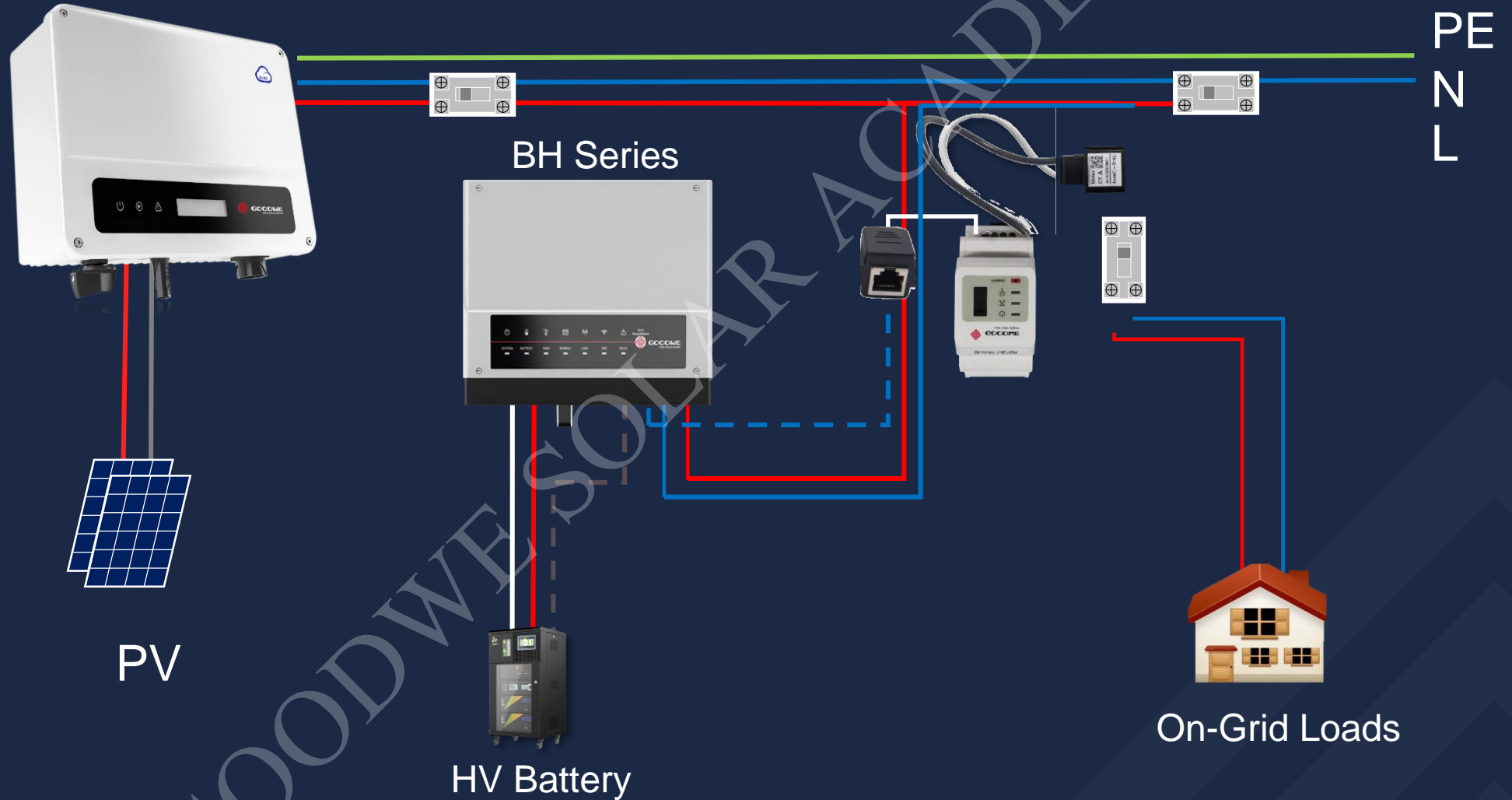

Capacity Expansion Solution – Hybrid Inverters

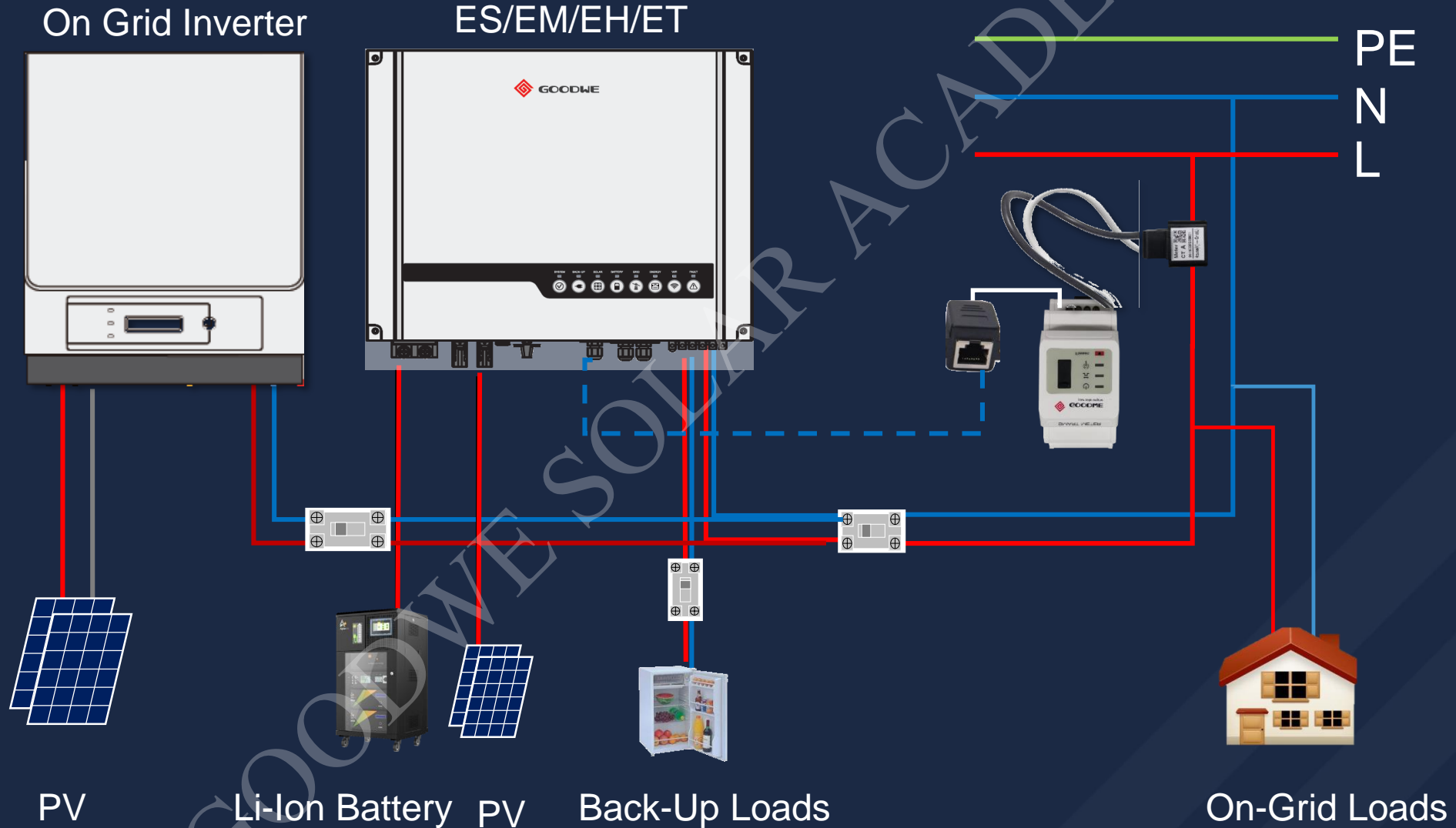

Capacity Expansion Solution – Hybrid Inverters

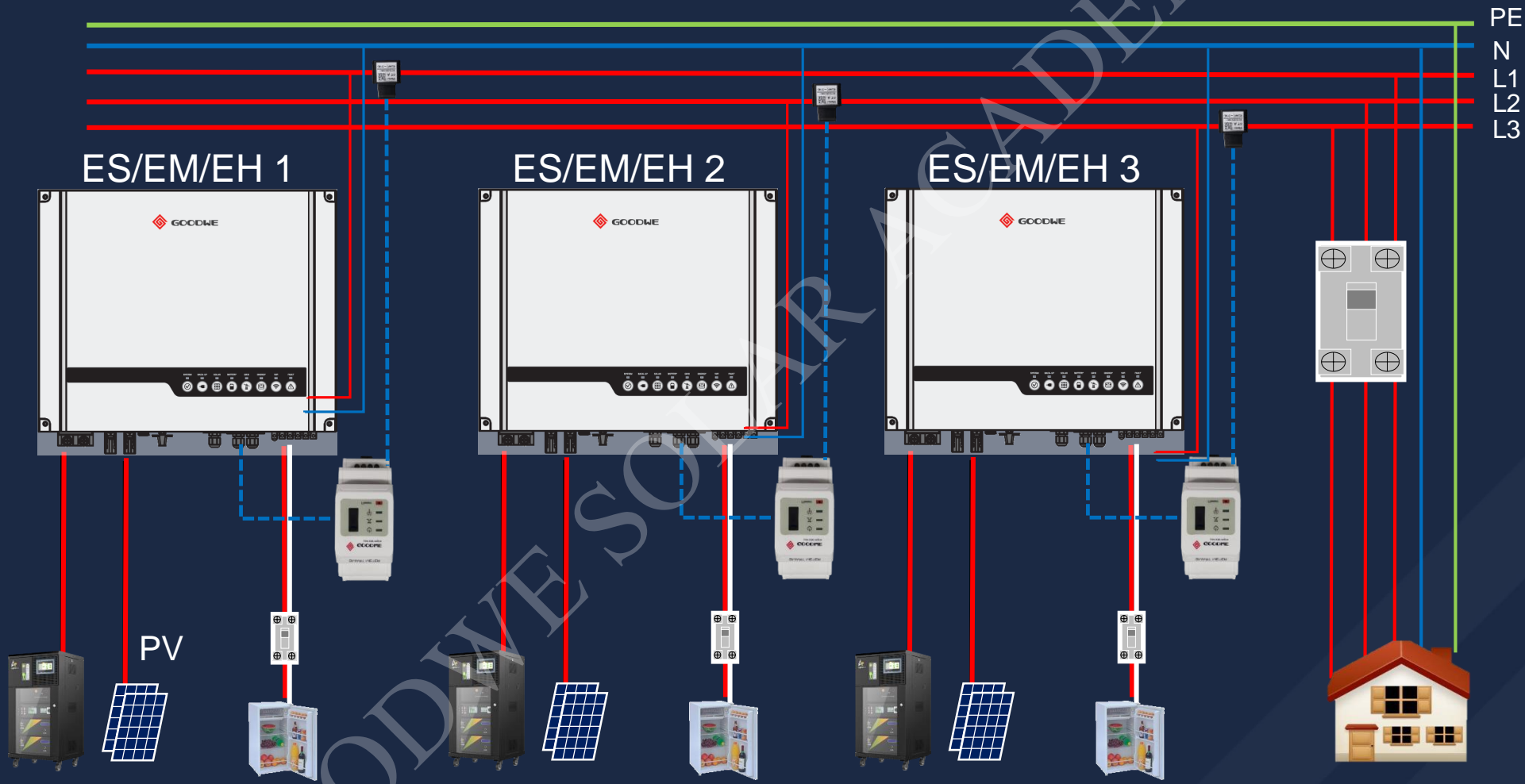

Li-Ion Battery Back-Up Loads

On-Grid Three phase Loads

Capacity Expansion Solution – ET Series



OPERATION SCENARIO

GOODWE SOLAR ACADEMY



**ACROSS THE OCEAN
TO STAY WITH YOU**

OPERATION SCENARIO

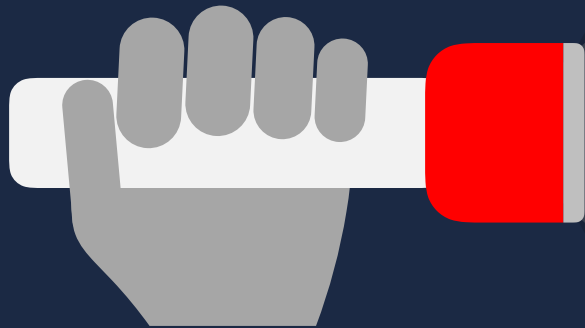

The most common application scenarios

01. Weak Grid Condition

Utility not available or not stable

02. Important Loads

UPS loads require uninterrupted supply

03. Export Power Limit

Control the output power exporting to grid

04. Self-Use

Use hybrid system to maximize self-use ratio

05. High Utility Cost

Storage energy to save utility cost

GOODWE SOLAR ACADEMY

THANK YOU!

**FACEBOOK:
GOODWESOLARACADEMY**

